

CONTENTS

I.	PRODUCT	1
1.1	PRODUCT MODEL NAMING RULE	1
1.2	OPTIONAL FUNCTION NAMING RULE	2
1.3	NAMEPLATE	3
1.4	APPEARANCE	3
1.5	TECHNICAL PARAMETERS	4
1.6	TECHNICAL SPECIFICATIONS	5
1.7	OPTIONAL ACCESSORY	7
1.8	DESIGNED STANDARDS FOR IMPLEMENTATION	144
1.9	SAFE INSTRUCTIONS AND PRECAUTIONS	144
1.10	EXAMINATION AND MAINTENANCE	166
II.	KEYPAD PANEL	177
2.1	<i>Panel Illustration</i>	177
2.2	<i>Keypad panel and installation bracket structure</i>	188
2.3	<i>Panel Operating</i>	20
2.4	<i>Parameters Setting</i>	20
2.5	<i>Function Codes Switchover in/between Code-Groups</i>	21
2.6	<i>Operating instructions of 4-line LCD interface switch</i>	23
2.7	<i>Panel Display</i>	24
III.	INSTALLATION & CONNECTION	255
3.1	Periphery Wiring	255
3.2	Installation	277
3.3	Connection	299
3.4	Functions of control terminals	30
3.5	Measurement of main circuit(voltages, currents and powers)	344
3.6	Wiring Recommended	366

3.7	Lead section area of protect conductor (grounding wire)	366
3.8	Overall Connection	377
3.9	Solutions of conductions and radiation interference	388
IV.	OPERATION AND SIMPLE RUNNING	443
4.1	Basic conception	443
4.2	Keypad panel and operation method	444
4.3	Illustration of basic operation	477
V.	FUNCTION PARAMETERS	52
5.1	Basic parameters	52
5.2	Operation Control	61
5.3	Multifunctional Input and Output Terminals	699
5.4	Analog Input and Output	82
5.5	Pulse Input and Output Control	855
5.6	Multi-stage Speed Control	899
5.7	Auxiliary Functions	92
5.8	Malfunction and Protection	100
5.9	Parameters of the Motor	105
5.10	Communication Parameter	1100
5.11	PID Parameters	1111
5.12	Torque control parameters	124
5.13	Time setting	12727
5.14	Parameters of the second motor	12730
5.13	Parameters Display	12730
VI.	MAINTENANCE	132
6.1.	Daily Inspection	132
6.2.	Periodic Maintenance	132
6.3.	Exchange of Vulnerable parts	13333
6.4.	Storage	133

VII. MOTOR	1344
7.1. Motor Nameplate	1344
7.2. Naming Rule	1344
7.3. Motor Technical Specification	136
7.4. Motor Type	136
7.5. Reference Table of inverter and motor	137
7.6. Motor Installation Size	138
7.7. Installation	14141
7.8. Trouble Shooting	141
7.9. Maintenance & Servicing	143
Appendix 1 Trouble Shooting	144
Appendix 2 Reference Wiring of water system	147
Appendix 3 Products & Structures	149
Appendix 4 Selection of Braking Resistance	15353
Appendix 5 Communication Manual	154
Appendix 6 Zoom Table of Function Code	165
Appendix 7 Master/slave control	20201
Appendix 8 Instructions for time period control	204

I. Product

This manual offers a brief introduction of the installation connection, parameters setting and operations for EM30 series inverters, and should therefore be properly kept. Please contact manufacturer or dealer in case of any malfunction during application.

1.1 Product model naming rule

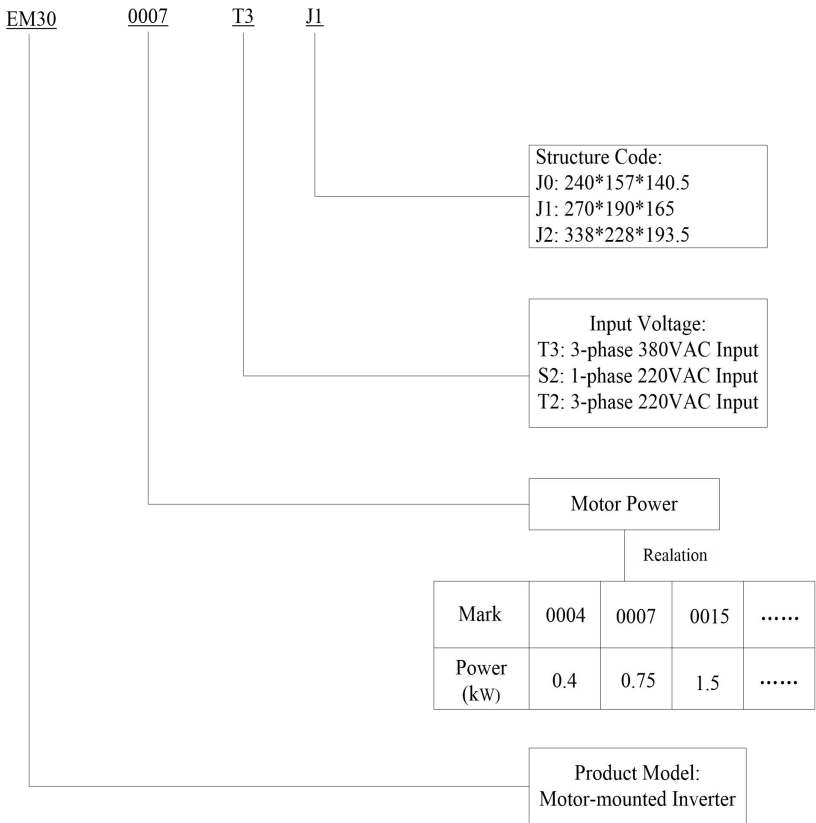

1.2 Optional function naming rule

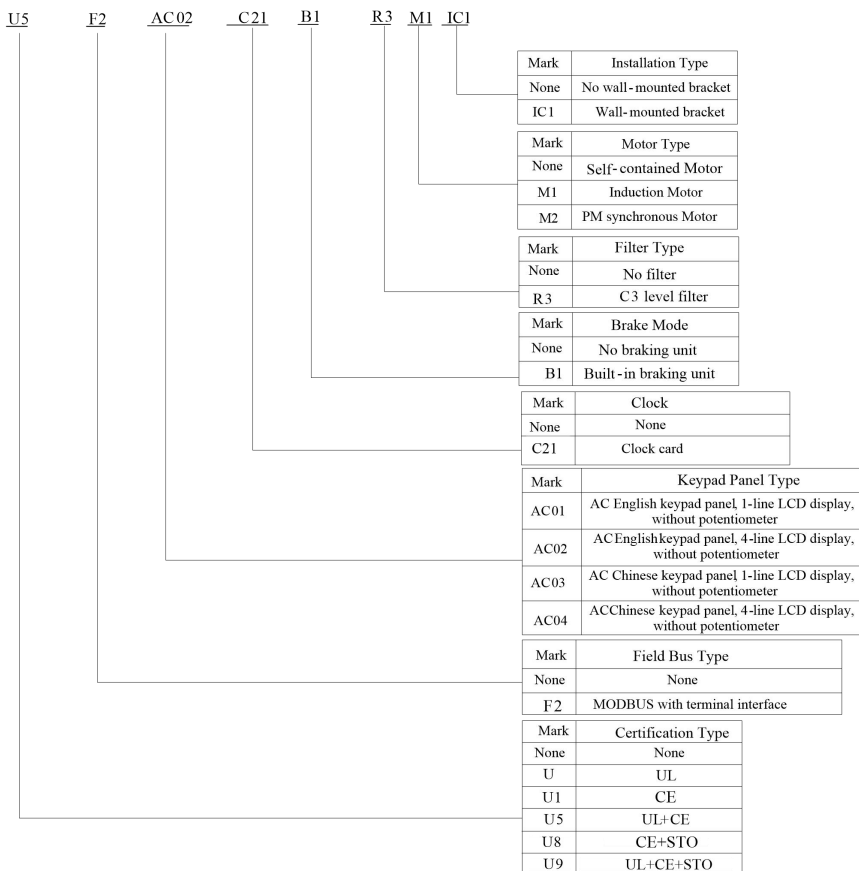

Note:

1. STO is only valid for J0.
2. J0 meets R3 level requirements. R3 is EMC C3 level, (test conditions: 5-meter motor wire).

1.3 Nameplate

Taking for instance the EM30 series 7.5kW inverter with 3-phase 400V input, its nameplate is illustrated as Fig 1-1.

3Ph AC: 3-phase input;

380~480V, 50/60Hz: Input voltage range and rated frequency.

3Ph: 3-phase output; 17A, 7.5kW: Rated output current and power;



MODEL	EM30-0030T2J1	OPTION	U5F2AC02B1R3
INPUT	3PH AC 380~480 V 50/60Hz		1.Maximum Ambient Temperature 40°C. 2.Solid State motor overload protection reacts when reaches 150% of FLA. 3.Install device in pollution degree 3 environment.
OUTPUT	3PH AC 0-INPUT V 2.0 A 0.75 kW		
 		<div style="border: 1px solid black; padding: 2px; display: inline-block;">BAR CODE</div> SW NO. 1.02 BS NO. 2.001	
		Made In PRC	

Fig 1-1 Nameplate

Note: Integrated inverter model include product model and optional function model. Make sure to fill with complete integrated inverter model when making an order.

1.4 Appearance

The external structure of EM30 series inverter: die-casting aluminum housing, anti-fingerprints fabrication processing, unique shape, high strength, good tenacity and convenience for maintenance. Taking EM30-0022T3J1 for instance, the external appearance and structure are shown as below in Fig1-2.

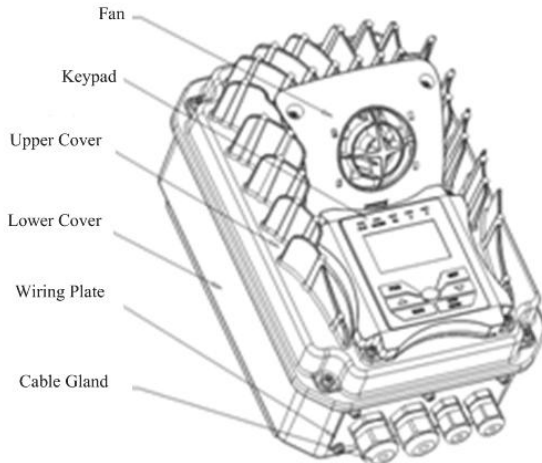

Fig 1-2 Appearance and Structure

Exquisite structure design of aluminum casting housing, detachable cover structure and convenient connection can realize perfect combination with motor. Take EM30-0075T3J2 for instance, the external appearance and structure are shown as below in Fig1-3.

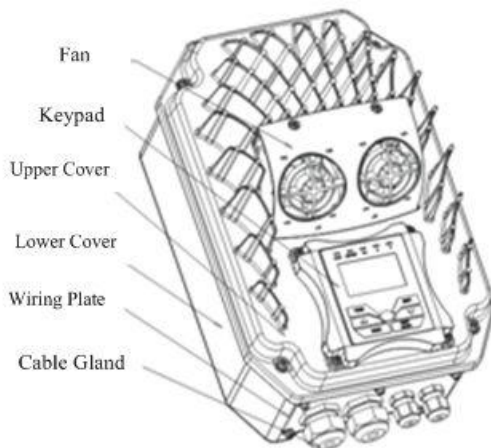

Fig 1-3 Appearance and Structure

1.5 Technical parameters

Power supply	Model	Motor power (kW)	Rated output current (A)	Input protection current (A)
1Ph 230V	EM30-0004S2	0.4	2.5	10.0
	EM30-0007S2	0.75	4.5	18.1
	EM30-0015S2	1.5	7	25.2
	EM30-0022S2	2.2	10	32.0
3Ph 230V	EM30-0004T2	0.4	2.5	10.0
	EM30-0007T2	0.75	4.5	17.0
	EM30-0015T2	1.5	7	17.5
	EM30-0022T2	2.2	10	25.0
	EM30-0030T2	3.0	12	30.0
	EM30-0040T2	4.0	17	42.5
	EM30-0055T2	5.5	21	53.0
3Ph	EM30-0007T3	0.75	2	6.5

400v	EM30-0015T3	1.5	4	11
	EM30-0022T3	2.2	6.5	15.0
	EM30-0030T3	3.0	7.6	16
	EM30-0040T3	4.0	9	21.0
	EM30-0055T3	5.5	12	29.0
	EM30-0075T3	7.5	17	34.0
	EM30-0110T3	11	23	46.5

1.6 Technical Specifications

Table1-1 Technical Specifications for EM 30 Series Inverters

	Items	Contents
Input	Rated Voltage Range	T3 380V-480V(+10%/-15%); S2/T2 220V-240V (±15%) S2 220V~240V(±15%)
	Rated Frequency	50/60Hz
Output	Rated Voltage Range	3-Phase: 0-INPUT(V)
	Frequency Range	0.50~590.0HZ (In Vector Control Mode: Max frequency is not allowed to exceed 500.00Hz)
Control Mode	Control Method	Induction Motor: Sensorless Vector Control (SVC), V/F control; PMSM: open-loop vector control (SVC)
	Modulation Mode	Space Vector PWM
	Control Mode	Speed, torque
	Motor type	Asynchronous /permanent magnet synchronous motor
	Carrier Frequency	0.8~16KHz;Fixed carrier-wave and random carrier-wave (F159)
	Speed-control Scope	Induction Motor-SVC 1:100; PMSM-SVC 1:20;
	Steady Speed Precision	±0.5% (SVC)
	Torque Response	<20ms (SVC)
	Torque Control Precision	±5% (SVC)
	Start Torque	0.5 Hz/100% (VVVF); 0.5Hz/150%(SVC)
	DC Braking	DC braking frequency: 0.20-50.00 Hz; Braking time: 0.00~30.00s; Braking current: 0.0~100%
Overload capacity	150% of rated current, 60s	
Operation Function	Start/Stop Control	Terminal control, keypad control or communication control.
	Frequency Setting mode	Potentiometer or external analog signal (0~5V, 0~10V, 0~20mA); Keypad (terminals) up/down key; External control logic and self-circulation setting.
	Main Frequency Source	Digital given memory, external analogue AI1, AI2, input pulse frequency given(100KHZ), digital given without memory, PID, MODBUS
	Auxiliary Frequency Source	Flexible auxiliary frequency trim and the operate mode of main and auxiliary frequency.
	Auto voltage regulation (AVR)	When source voltage changes, the modulation rate can be adjusted automatically, so that the output voltage is unchanged.

	Auto Carrier Modulation	Temperature controlled carrier frequency, preventing overheating protection
	Auto fast current limiting	Minimize OC protection as much as possible
	Auto overvoltage adjustment	PN voltage auto adjustment
	Torque Limitation and Control	Excavator characteristics, automatic torque limit.
	Restart after speed track	Realize no impact on the rotating motor and smooth start.
	Oscillation suppression	Oscillation suppression
	Jogging Control	Jogging frequency range: min frequency~ max frequency, Jogging acceleration/deceleration time: 0.1~3000.0s
	Terminal self-test function	Self check of digital and analog input/output terminals can be performed through keypad and upper computer
	Common DC bus	Common DC bus
	Instant power failure without stopping the drive	Compensate for voltage reduction through load feedback energy to ensure the continuous operation of the drive in a short period of time.
	Built in process closed-loop	Built-in PID
	Analog input	2-channel(AI1/AI2)
	Analog output	2-channel(AO1/AO2)
	Digit input	5-channel general-form input; 1-channel high-speed pulse input Max frequency: 100Khz, Internal impedance: 3.3KΩ;
	Digit output	1-channel DO1
	Relay output	2-channel programmable relay output
Keypad	1-line/4-line LCD	Support
	Parameter copy	Clone module supported.
Protection Function	Power supply under-voltage, phase loss, DC over-voltage, over-current, inverter overload, motor overload, output phase loss, overheat, external disturbance, parameter measure failure, analog line disconnected protection, DC-GND short circuit, water shortage protection, pressure protection, dormant state.	
Environmental Conditions	Environment Temperature	-10℃~+40℃
	Environment Humidity	Below 90% (no water-bead coagulation)
	Vibration Strength	4G
	Height above sea level	1000m or below(Derating use when above 1000m)
Protection level	IP66	
Applicable Motor	0.4~11kW	
Efficiency	≥93%	
Others	Cooling Mode	Force-air cooling
	Braking Unit	Built-in braking unit needs external braking resistor.
	Fan	Draught fan is pluggable.
	Installation Mode	Support installing with motor

Note:

1. When input voltage is higher than 420V, please contact with manufacture.

1.7 Optional Accessory

If in need, optional accessories should be mentioned when ordering.

Table 1-2 EM30 remote keypad accessories

Power range	Product code	Remark
0.4kW~11kW	AD-A01	Outer lead length noted

Table 1-3 EM30 motor adapter plate accessories of case 1

Power range	Structure	Accessories code
S2/T2/T3: 0.4~0.75kW	J1	EJ1ZJ01
S2/T2/T3: 1.5~3.0kW	J1	EJ1ZJ02
T3: 4.0 kW	J1	EJ1ZJ03
T3:5.5~11 kW T2: 4.0~5.5 kW	J2	EJ2ZJ01

Table 1-3 EM30 motor adapter plate accessories of case 2

Power range	Structure	Accessories code
S2: 0.4~2.2kW T2: 0.4~2.2kW T3: 0.75~3.0kW	J0	EJ0ZJ11
S2: 0.4~2.2kW T2: 0.4~3.0kW T3: 0.75~4.0kW	J1	EJ1ZJ11
T3: 5.5~11kW T2: 4.0~5.5kW	J2	EJ2ZJ11

When the distance between the junction box position and the driver is not enough, adapter should be added.

The installation diagram of J0 motor adapter plate is as follows:

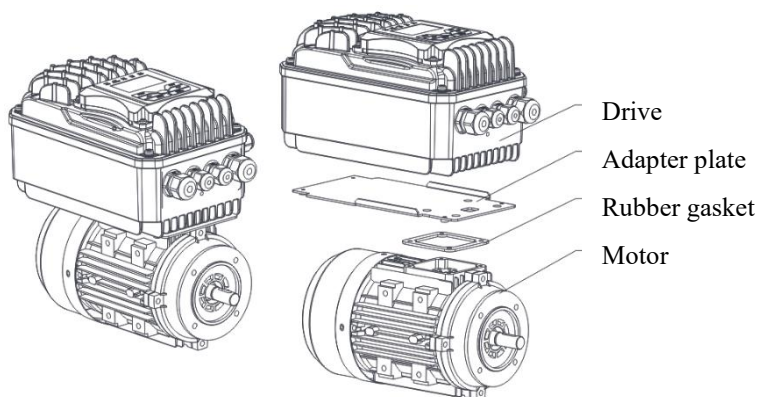

Fig1-7 Motor adapter plate installation of case 2

The installation diagram of J1/J2 motor adapter plate is as follows:

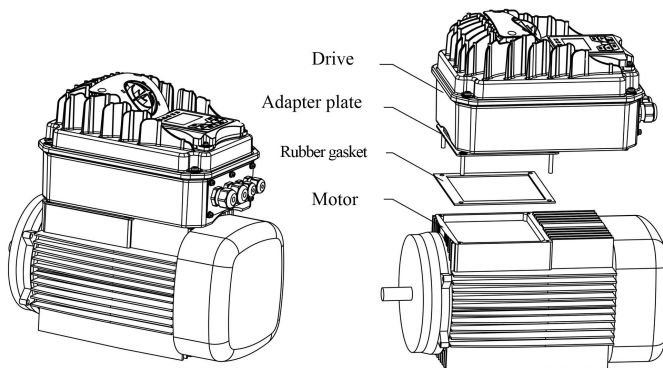

Fig1-8 Motor adapter plate installation of case 2

EM30-J0 metal adapter plate

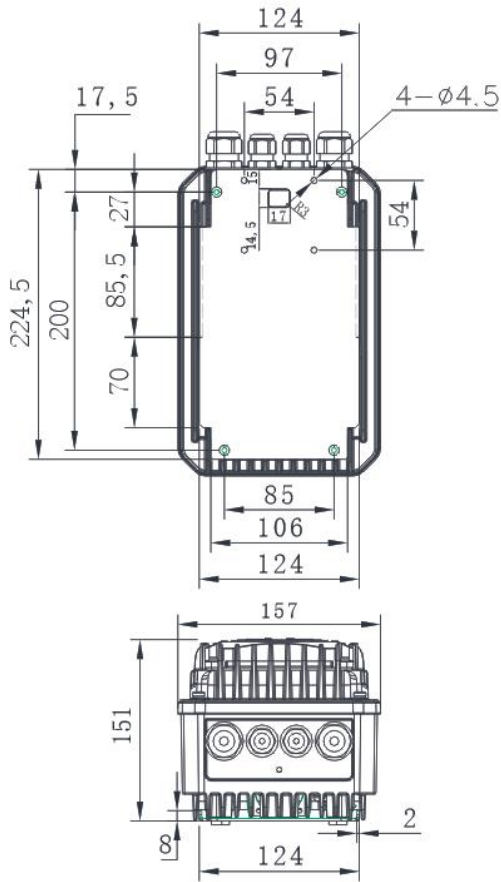
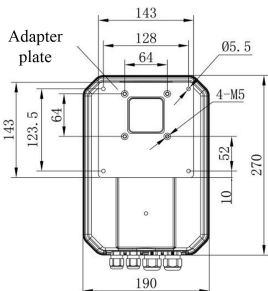
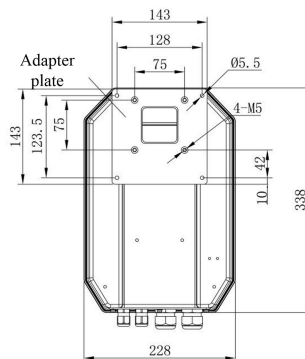

Fig1-9 Metal adapter plate dimension

EM30-J1 metal adapter plate



EM30-J2 metal adapter plate

**Fig1-10 Metal adapter plate dimension**

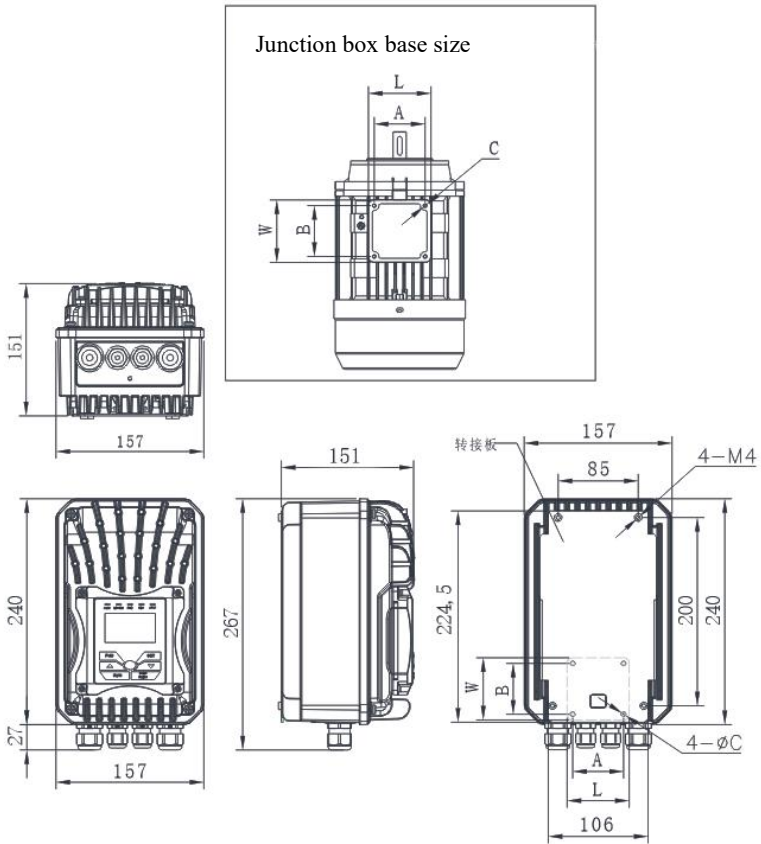

Fig1-11 J0 drive and motor adapter plate size

Note: L, W are the external size of motor junction box base, A, B are installation size of motor junction box base, C is the screw hole size of between adapter plate and motor junction box base.

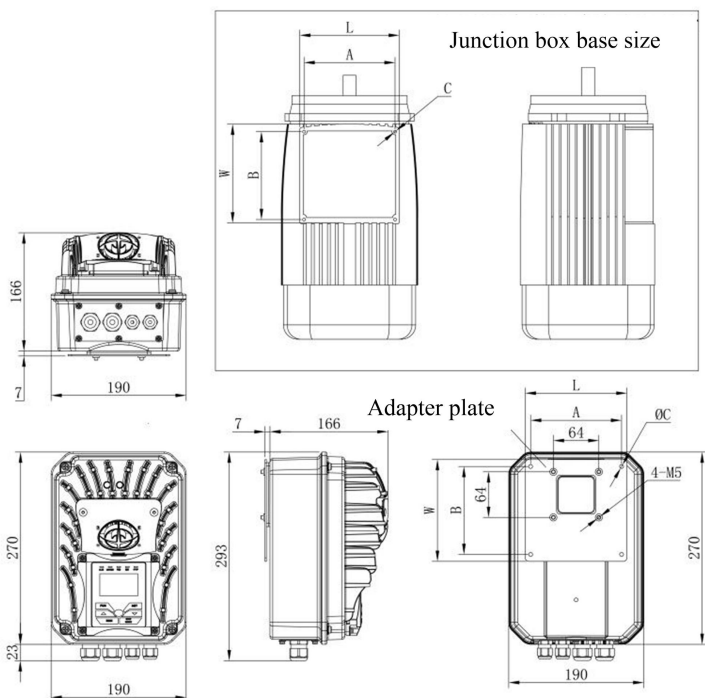

Fig1-12 J1 drive and motor adapter plate size

Note: L, W are the external size of motor junction box base, A, B are installation size of motor junction box base, C is the screw hole size of between adapter plate and motor junction box base.

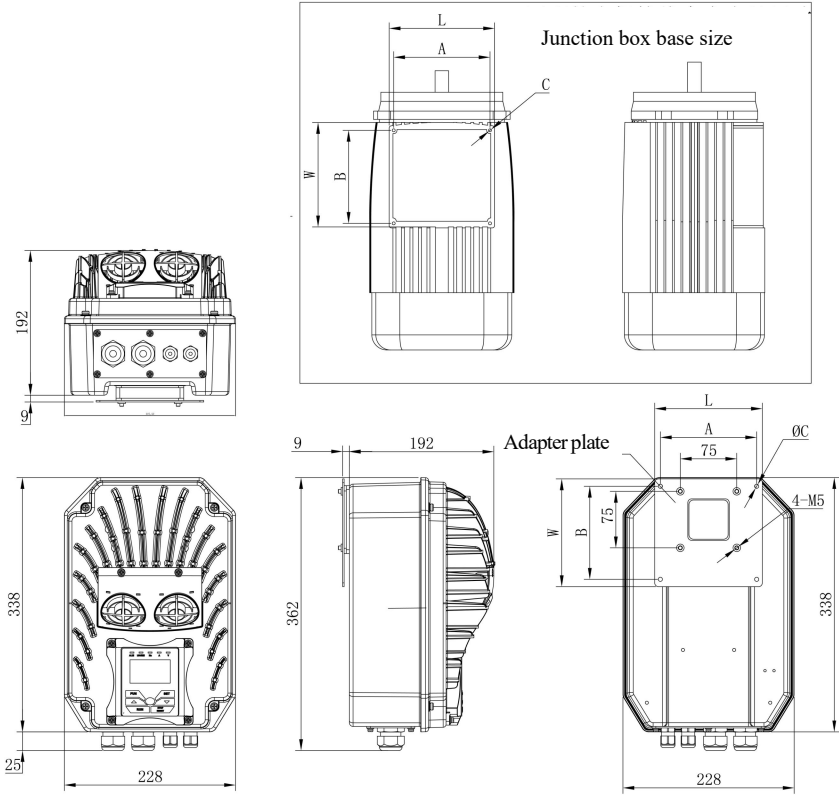

Fig1-13 J2 drive and motor adapter plate size

Note: L, W are the external size of motor junction box base, A, B are installation size of motor junction box base, C is the screw hole size of between adapter plate and motor junction box base.

Table 1-5 EM30 keypad outer accessory

Structure	M type cable fixed head	Cable outer diameter(mm)	Color	Recommended model	QTY
J0	M20×1.5	10~14	Black	Cable fixed sleeve M2014B	2
	M16×1.5	5~10	Black	Cable fixed sleeve M1610B	2
	M16×1.5	5~10	Black	Cable fixed sleeve M1610B	1
J1	M20×1.5	10~14	Black	Cable fixed sleeve M2014B	2
	M16×1.5	5~10	Black	Cable fixed sleeve M1610B	2
J2	M25×1.5	13~18	Black	Cable fixed sleeve M2518B	2
	M16×1.5	5~10	Black	Cable fixed sleeve M1610B	2

1.8 Designed Standards for Implementation

IEC/EN 61800-5-1: 2007 Adjustable speed electrical power drive systems safety requirements.

IEC/EN 61800-3: 2004/+A1: 2012 Adjustable speed electrical power drive systems-Part 3: EMC product standard including specific test methods.

1.9 Safe Instructions and Precautions

- Please check the model in the nameplate of the inverter and the rated value of the inverter. Please do not use the damaged inverter in transit.
- Installation and application environment should be free of rain, drips, steam, dust and oily dirt; without corrosive or flammable gases or liquids, metal particles or metal powder. Environment temperature within the scope of $-10^{\circ}\text{C}\sim+40^{\circ}\text{C}$.
- Please install inverter away from combustibles.
- Do not drop anything into the inverter.
- The reliability of inverters relies heavily on the temperature. The around temperature increases by 10°C , inverter life will be halved. Because of the wrong installation or fixing, the temperature of inverter will increase and inverter will be damaged.
- Inverter is installed in a control cabinet, and smooth ventilation should be ensured and inverter should be installed vertically. If there are several inverters in one cabinet, in order to ensure ventilation, please install inverters side by side. If it is necessary to install several inverters up and down, please add heat-insulation plate.
- Never touch the internal elements within 15 minutes after power off. Wait till it is completely discharged.
- Input terminals L1/R, L2/S and L3/T are connected to power supply of 400V/230V (L1, L2 are connected to 230V) while output terminals U, V and W are connected to motor.
- Proper grounding should be ensured with grounding resistance not exceeding 4Ω ; separate grounding is required for motor and inverter. Grounding with series connection is forbidden.

- There should be separate wiring between control loop and power loop to avoid any possible interference.
- Signal line should not be too long (less than 3m) to avoid any increase with common mode interference.
- If circuit breaker or contactor needs to be connected between the drive and the motor, be sure to operate these circuit breakers or contactor when the drive has no output, to avoid damaging of drive.
- Meet the environmental requirements of EM30 series technical specifications in table 1-1.
- Before using the drive, the insulation of the motors must be checked, especially, if it is used for the first time or if it has been stored for a long time. This is to reduce the risk of the drive from being damaged by the poor insulation of the motor.
- Do not connect any varistor or capacitor to the output terminals of the drive, because the drive's output voltage waveform is pulse wave, otherwise tripping or damaging of components may occur; in addition, do not install circuit breaker or contactor at the output side of the drive as shown in Fig 1-4.

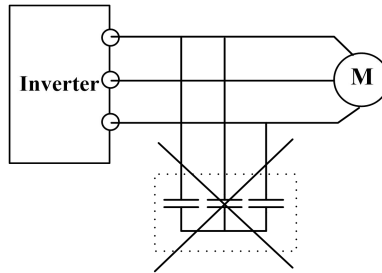

Fig 1-4 Capacitors are prohibited to be used.

- Derating must be considered when the drive is installed at high altitude, greater than 1000m. This is because the cooling effect of drive is deteriorated due to the thin air, as shown in Fig. 1-5 that indicates the relationship between the elevation and rated current of the drive.

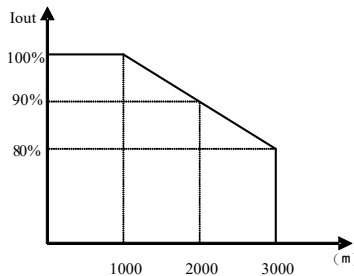



Fig 1-5 Derating drive's output current with altitude

- Never touch high-voltage terminals inside the inverter to avoid any electric shock.
- Before inverter is powered on, please be sure that input voltage is correct.
- Please do not connect input power supply onto U, V, W or  terminals.
- Please do not install inverter directly under sunshine, do not block up the cooling hole.
- All safety covers should be well fixed before inverter is power connected, to avoid any electric shock.
- Only professional personnel are allowed for any maintenance, checking or replacement of parts.
- No live-line work is allowed.

1.10 Examination and Maintenance

1.10.1 Periodic checking

- Cooling fan and wind channel should be cleaned regularly to check whether it is normal; remove the dust accumulated in the inverter on a regular basis.
- Check inverter's input and output wiring and wiring terminals regularly and check if wirings are ageing.
- Check whether screws on each terminals are fastened.
- Check whether inverter is corrosive.

1.10.2 Storage

- Please put the inverter in the packing case of manufacture.
- If inverter is stored for long time, please charge the inverter every half a year to prevent the electrolytic capacitors damaged. The charging time should be longer than 5 hours.

1.10.3 Daily Maintenance

Environment temperature, humidity, dust and vibration would decrease the life of inverter. Daily maintenance is necessary to inverters.

Daily inspecting:

- Inspecting for noise of motor when it is working.
- Inspecting for abnormal vibration of motor when it is working.
- Inspecting for the installing environment of inverter.
- Inspecting for the fan and inverter temperature.

Daily cleaning:

- Keep the inverter clean. Clean surface dust of inverter to prevent dust, metal powder, oily dirt and water from dropping into the inverter.

II. Keypad panel

The keypad function and indicator function for EM30 series will be showed in panel operating illustration.

2.1 Panel Illustration

The panel covers three sections: data display section, status indicating section and keypad operating section, as shown in Fig. 2-1.

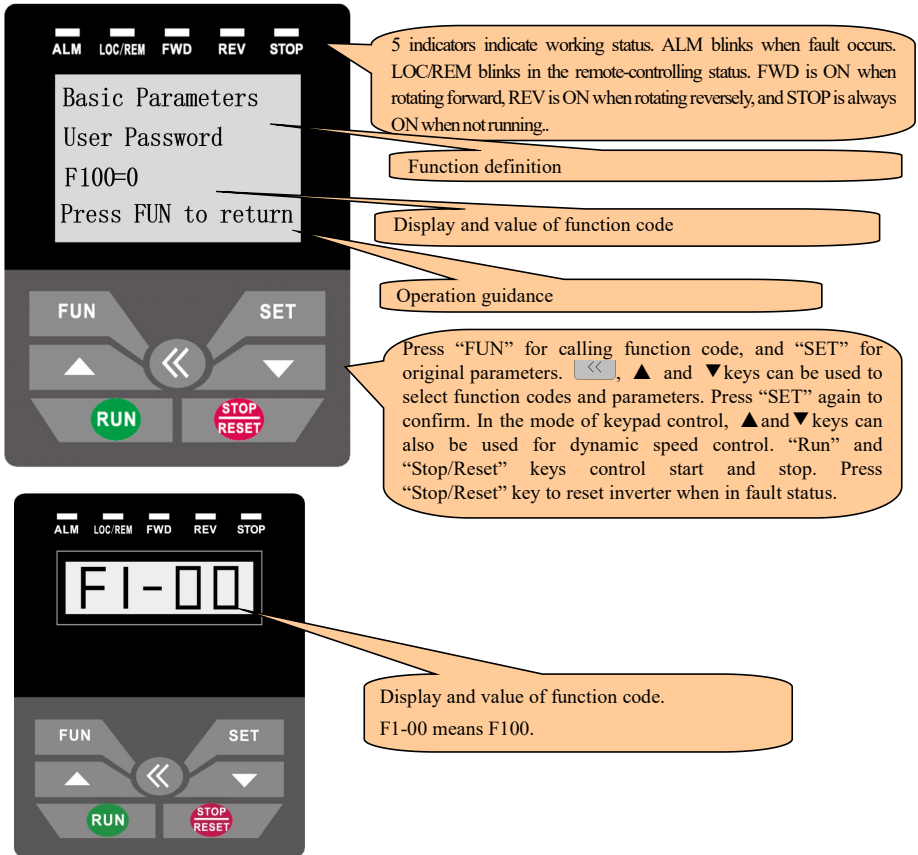

Fig.2-1 Operation Panels

Instructions for operation panel:

1. Local keypad panel can be introduced remotely. Select remote fittings if remote panel is needed.

2.2 Keypad panel and installation bracket structure

2.2.1 Structure Diagram

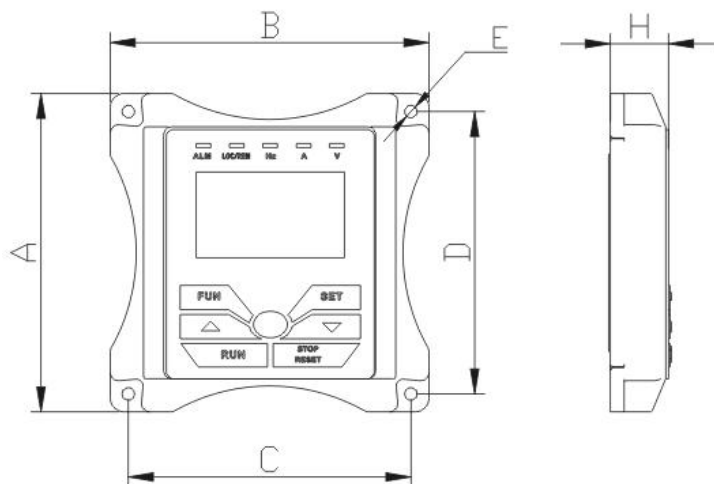

2.2.2 Structure Size for remote keypad panel (Unit: mm)

Code		A	B	C	D	H	E
AC-A-02	4-line LCD	115	115	102	102	21	Φ4.5

2.2.3 Port of Control Panel

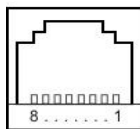

Pins	1	2	3	4	5	6	7	8
8 core	Reserved	5V	5V GND	5V GND	Signal 1	Signal 2	Signal 3	Signal 4

Note: The interface of control board should be completely consistent with the interface of the keypad panel, so the line sequence should also be the same.

2.2.4 The remote-control components should reach the protection grade. The default remote-control wire length is 1m. The length of remote-control wire can be custom-made by users. If on the occasion of strong interference of occasion, or the length is longer than 3m, please put a magnetic ring on the wire to avoid interference. The figures of remote-control components are showed as below:

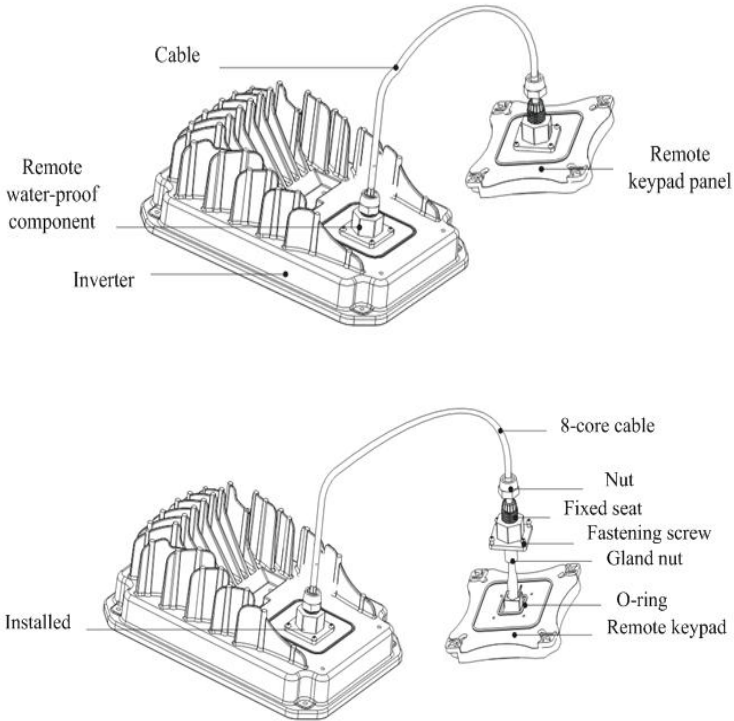



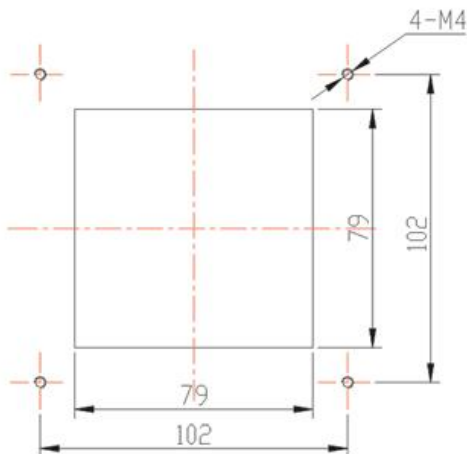



2.2.5 Remote keypad hole dimension figure



2.3 Panel Operating

All keys on the panel are available for user. Refer to Table 2-1 for their functions.

Table 2-1 Uses of Keys















Keys	Names	Remarks
	Fun	To call function code and switch over display mode.
	Set	To call and save data.
	Up	To increase data (speed control or setting parameters)
	Down	To decrease data (speed control or setting parameters)
	Run	To start inverter;
	Stop or reset	To stop inverter; to reset in fault status;
	Shift key	Shift and displaying items switchover.

2.4 Parameters Setting

This inverter has numerous function parameters, user can modify to effect different modes of operation

control. User needs to realize that if user sets password valid (F107=1), user's password must be entered firstly if parameters need to set after power off or protection is effected, i.e., to call F100 as per the mode in Table 2-2 and enter the correct code. User's password is invalid when leaving factory and user could set corresponding parameters without entering password.

Table 2-2 Steps for Parameters Setting

Steps	Keys	Operation	Display
1		Press "Fun" key to display function code	
2	 or 	Press "Up" or "Down" to select required function code	
3		To read data set in the function code	
4	 or 	To modify data	
5		To display corresponding function code after saving the set data	
		To display the current function code	

The above-mentioned step should be operated when inverter is in stop status.

2.5 Function Codes Switchover in/between Code-Groups

It has more than 300 parameters (function codes) available to user, divided into 11 sections as indicated in Table 2-3.

Table 2-3 Function Code Partition

Group Name	Group No.	Group Name	Group No.
Basic Parameters	F1	Parameters of the motor	F8
Run Control Mode	F2	Communication parameters	F9
Multi-functional input/output terminal	F3	PID parameter setting	FA/FB
Analog signals and pulse of input/output	F4	Torque control parameters	FC
Multi-stage speed parameters	F5	Torque control	FD
Subsidiary function	F6	The second motor parameters	FE
Timing control and protection function	F7	Parameter display	H0

As parameters setting costs time due to numerous function codes, such function is specially designed as "Function Code Switchover in a Code Group or between Two Code-Groups" so that parameters setting

become convenient and simple.

The operation of segment LCD:

Press “Fun” key so that the keypad controller will display function code. If press “▲” or “▼” key then, function code will circularly keep increasing or decreasing by degrees within the group; if press  key, function code will change circularly between two code groups when operating the “▲” or “▼” key.

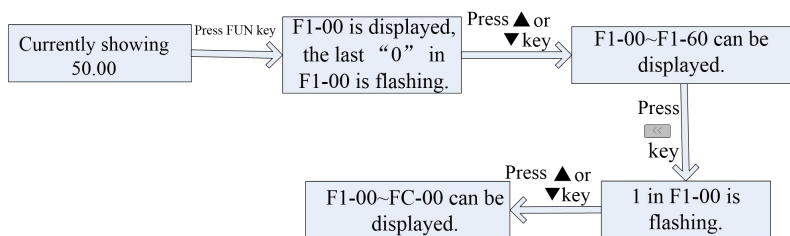



Fig 2-2 Switch over in a Code Group or between Different Code-Groups

The operation of four-line LCD:

When function code shows F100 and the last “0” in F100 is flashing, after pressing  key, the middle “0” is flashing, then press  again, “1” in F100 is flashing, the flashing value can be changed by pressing “▲”/“▼” key.

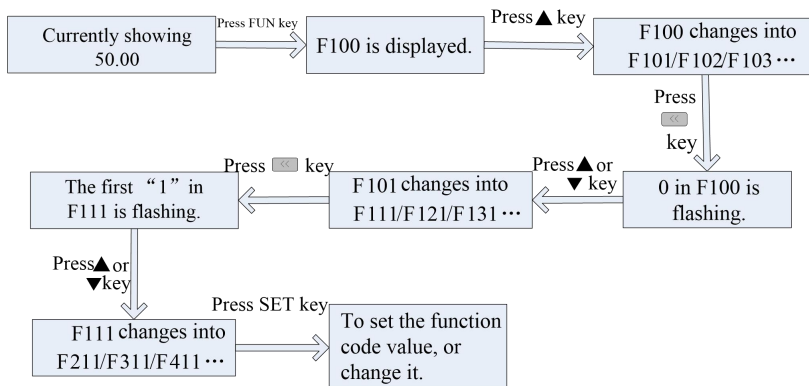

Fig 2-3 Switch over in a Code Group or between Different Code-Groups

2.6 Operating instructions of 4-line LCD interface switch

2.6.1 Operating instructions of SET/FUN keys

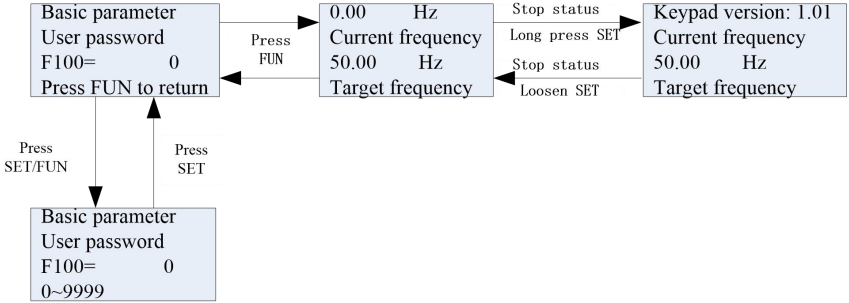

Fig 2-4 Operating flow chart of interface switch

2.6.2 Operating instructions of inverter status display

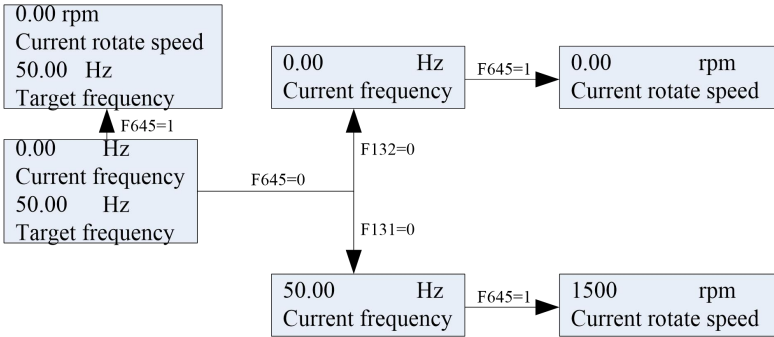

Fig 2-5 Operating flow chart of status parameter display

2.6.3 Regulating target frequency/target rotate speed by UP/DOWN keys in running status

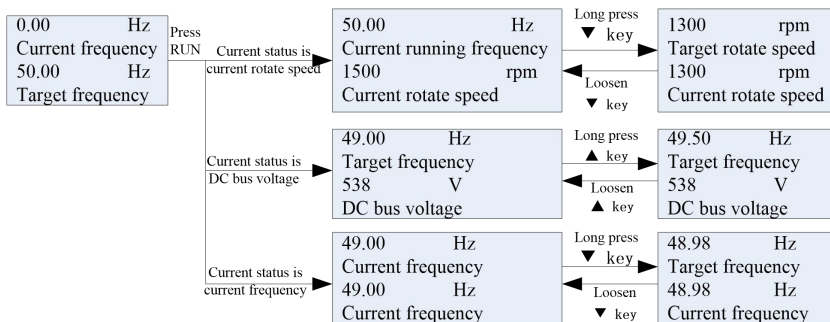

Fig 2-6 Operating flow chart of target frequency/rotate speed adjustments

2.7 Panel Display

Table 2-5 Items and Remarks Displayed on the Panel

Items	Remarks
-HF-(segment LCD)	It stands for resetting process and will display target frequency after reset.
Power on....	It stands for power on process.
OC, OC1, OE, OL1, OL2, OH, LU, PF0, PF1,PCE	Fault code, indicating “over-current OC”, “over-current OC1”, “over-voltage”, “inverter over-load”, “motor over-load” “over-heat”, “under-voltage for input”, “phase loss for output”, “phase loss for input”, and “detuning fault” respectively.
AErr, EP, nP, Err5	Analog line disconnected, inverter under-load, pressure control, PID parameters are set wrong.
ESP	During two-line/three line running mode, “stop/reset” key is pressed or external emergency stop terminal is closed, ESP will be displayed.
F152	Function code (parameter code).
10.00	Indicating inverter’s current running frequency (or rotate speed) and parameter setting values, etc.
50.00	Blinking in stopping status to display target frequency.
0.	Holding time when changing the running direction. When “Stop” or “Free Stop” command is executed, the holding time can be canceled

III. Installation & Connection

3.1 Periphery Wiring

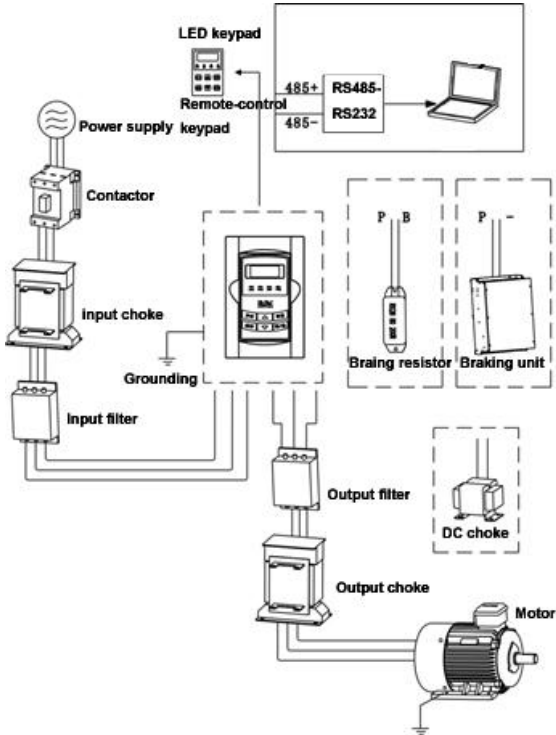



Note: Braking unit is built in the T3 model of EM30 series, braking resistor is need only if the load inertia is not too large.

3.1.1 Accessories Graphic Illustration

The brake part adopts a standard brake unit, the rest shows as below table 3-1:

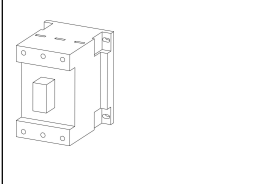
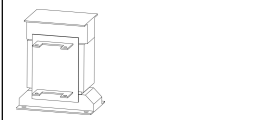
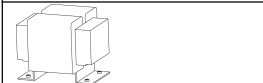
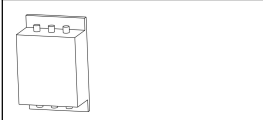
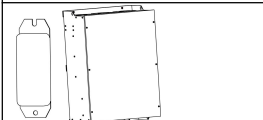
Table 3-1 Accessories Graphic Illustration

Picture	Name	Description
	Cables	Device to transfer the electronic signals
	Breaker	Prevent from electric shock or protect the power supply and the cables system from over-current when short circuits occur. (Please select the breaker with the function of reducing high order harmonic and the rated sensitive current to 1 one inverter should be above 30mA)
	Input choke	The device is used to improve the power factor of the input side of the inverter and control higher harmonic current.
	DC choke	
	Input filter	Control the electromagnetic interference generated from the inverter, please install close to the input terminal side of the inverter.
	Braking unit or resistor	Shorten the deceleration time.
	Output choke	Control the interference from the output side of the inverter, please install close to the output terminal side of the inverter.
	Output choke	Prolong the effective transmit distance of the inverter to control the sudden high voltage when switching on/off the IGBT of the inverter.

3.2 Installation

Inverter should be installed vertically, as shown in Fig 3-1. Sufficient ventilation space should be ensured in its surrounding. Clearance dimensions (recommended) are available from Table 3-1 for installing the inverter.

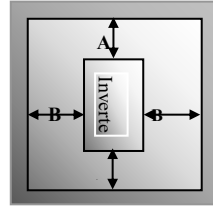
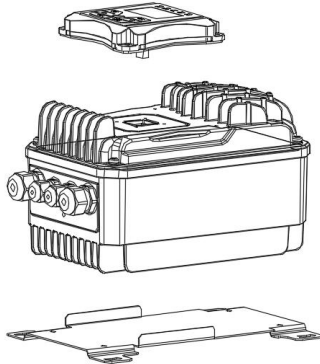

Fig 3-1 Installation Sketch

Table 3-2 Clearance Dimensions

Model	Clearance Dimensions	
Metal wall-mounted	$A \geq 200\text{mm}$	$B \geq 100\text{mm}$

The Figure below shows that J0 inverter is installed with adapter:



The Figure below shows that J0 inverter is installed with motor:

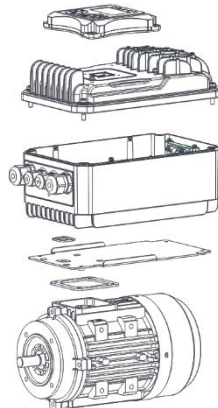

The Figure below shows that J1 inverter is installed with motor:

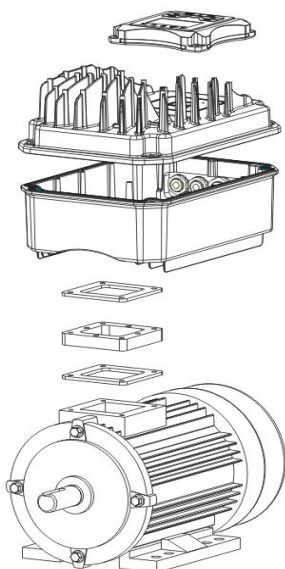

The Figure below shows that J1 inverter is installed with motor:

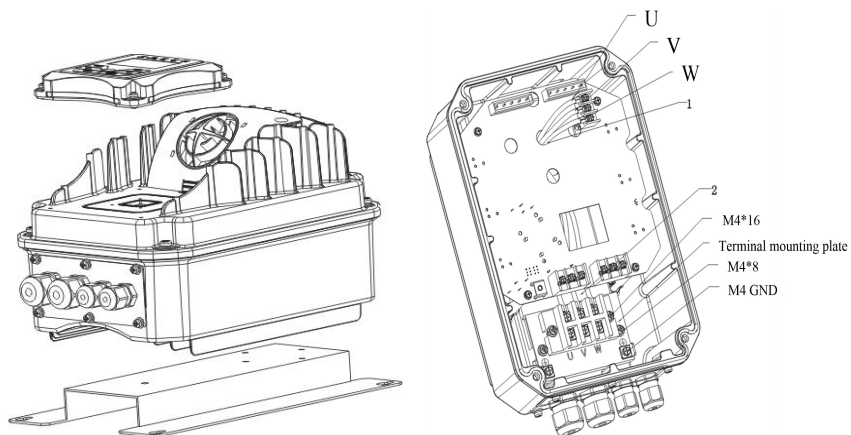

3.3 Connection

- Connect R/L1, S/L2 and T/L3 terminals (L1 and L2/N terminals for single-phase) with power source from network, φ /PE/E to earth, U, V and W terminals to motor.
- Motor must be ground connected. Or else electrified motor causes interference.

1) Power terminals sketch of inverter with 1-phase 230V 0.4-2.2KW showed as below in Fig 3-2.

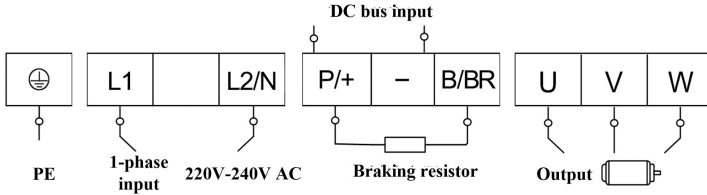

Fig 3-2 Power terminals sketch

2) Power terminals sketch of inverter with 3-phase 230V 0.4-5.5KW showed as below in Fig 3-3.

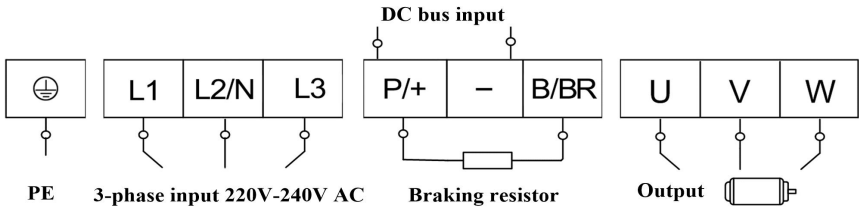

Fig 3-3 Power terminals sketch

3) Power terminals sketch of inverter with 3-phase 400V 0.75-15KW showed as below in Fig 3-4.

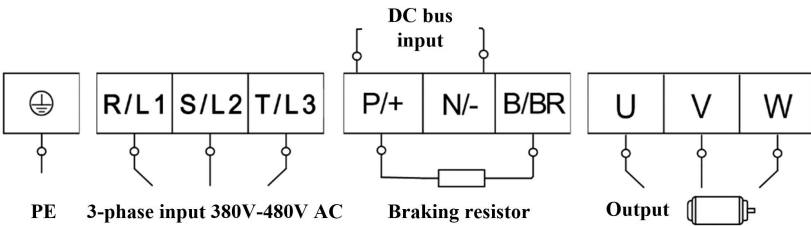



Fig 3-4 Power terminals sketch

Introduction of terminals of power loop

Terminals	Terminal Marking	Terminal Function Description
Power Input Terminal	R/L1, S/L2, T/L3	Input terminals of three-phase 400V AC voltage, 1-phase 230V connects to L1, L2/N, 3-phase 230V connects to L1, L2/N and L3.
Output Terminal	U, V, W	Inverter power output terminal, connected to motor.
Grounding Terminal		Inverter grounding terminal.
Rest Terminal	P/+, B/BR	External braking resistor terminals (Note: no Terminals P or B for inverter without built-in braking unit).
		Common DC bus terminals
	P/+, N/-	Externally connected to braking unit P/+ connected to input terminal “P/+” or “DC+” of braking unit, N/- connected to input terminal of braking unit “N/-” or “DC-”.

Wiring for control loop as follows:

TA1	TB1	TC1	TA2	TB2	TC2		DO1	24V	CM	CM	D11	D12	D13	D14	D15	D16	10V	A11	A12	GND	A01	A02	
GND	+5V	A+	B-		CANH/CANL																		
SR1	SR2	24V	FB	CM																			

SR1, SR2, 24V, FB, CM are optional terminals, for STO function.

3.4 Functions of control terminals

The key to operate the inverter is to operate the control terminals correctly and flexibly. The control terminals are not operated separately, and they should match corresponding settings of parameters. This chapter describes basic functions of the control terminals. The users may operate the control terminals by combining relevant contents hereafter about “Defined Functions of the Terminals”.

Table 3-3 Functions of Control Terminals

Terminal	Type	Description	Function
DO1	Digit Output	Multifunctional output terminal 1	When the token function is valid, the value between this terminal and CM is 0V; when the inverter stops, the value is 24V. TC is a common point, TB-TC is normally closed contacts, and TA-TC is normally open contacts. The contact capacity is 10A/125VAC、5A/250VAC、5A/30VDC. The functions of output terminals shall be defined per manufacturer’s value. Their initial state can be changed through changing function codes.
TA1		Relay contact	
TB1			
TC1			
TA2			
TB2			
TC2			
AO1	Analog output	Running frequency	It is connected with frequency meter, speedometer or ammeter externally, and its minus pole is connected with GND. See F423~F426 for details..
AO2		Current output	
10V	Analog power	Self contained power supply	Internal 10V self-contained power supply of the inverter provides power to the inverter. When used externally, it can only be used as the

	supply		power supply for voltage control signal, with current restricted below 20mA.	
AI1	Analog Input	Voltage / Current	AI1:0~5V、0~10V、0~20mA ;	
AI2		Analog input port	AI2:0~5V、0~10V、0~20mA	
GND	Analog grounding	Self-contained Power supply Ground	Ground terminal of external control signal (voltage control signal or current source control signal) is also the ground of 10V power supply of this inverter.	
24V	Power supply	Control power supply	Power: 24±1.5V, grounding is CM; Current is restricted below 200mA for external use.	
DI1	Digital input control terminal	Forward jogging	The functions of input terminals shall be defined per manufacturer's value. Other functions can also be defined by changing function codes.	
DI2		External scram		
DI3		“FWD” Terminal		When this terminal is valid, inverter will run forward.
DI4		“REV” Terminal		When this terminal is valid, inverter will run reversely.
DI5		Reset		
DI6		Free stop		Make this terminal valid during running can realize free stop.
CM	Common port	Grounding of control power supply	The grounding of 24V power supply and other control signals.	
+5V	Power supply	RS485 differential signal positive	RS-485 differential signal positive power supply	
A+	485 communication terminals	Positive polarity of differential signal	Standard: TIA/EIA-485(RS-485) Communication protocol: MODBUS Communication rate: 1200/2400/4800/9600/19200/38400/57600bps	
B-		Negative polarity of differential signal		
CAN _H ^{Not}	Communication terminal	CAN communication terminal high level	CAN_H bus line(dominant high)	
CAN _L ^{note}		CAN communication terminal low level	CAN_L bus line(dominant low)	
GND ^{note}		Signal grounding	Ground/0V/V-	

Note:

GND terminal is on the left side of drive, shielded twisted-pair cable is recommended for communication

cable. Please turn J8 coding switch of the first inverter and the last inverter on CAN communication to ON position, turn J8 coding switch of the other inverters on CAN communication to OFF position. Shielding layer is connected to ground by one spot.



Fig 4-5 Coding switch J8

Wiring for digital input terminals:

Generally, shield cable is adopted and wiring distance should be as short as possible. When active signal is adopted, it is necessary to take filter measures to prevent power supply interference. Mode of contact control is recommended.

Digital input terminals are only connected by common source electrode (NPN mode) or by common drain electrode (PNP mode). If NPN mode is adopted, please turn the toggle switch to the end of "NPN".

Wiring for control terminals as follows:

1. Wiring for positive source electrode (NPN mode).

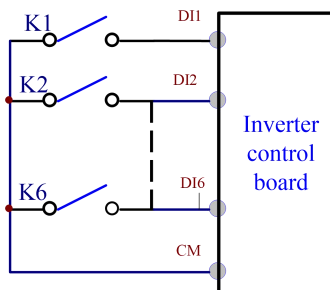

2. Wiring for active source electrode (NPN mode)

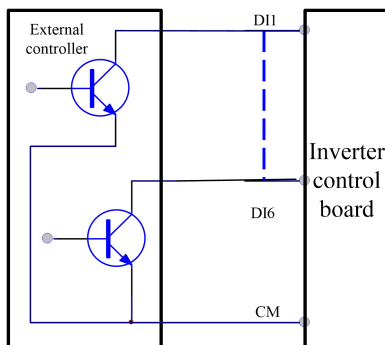

If digital input control terminals are connected by drain electrode, please turn the toggle switch to the end of "PNP". Wiring for control terminals as follows:

3. Wiring for positive drain electrode (PNP mode)

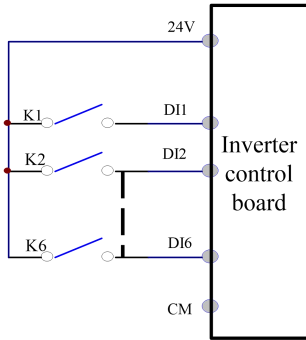

4. Wiring for active drain electrode (PNP mode)

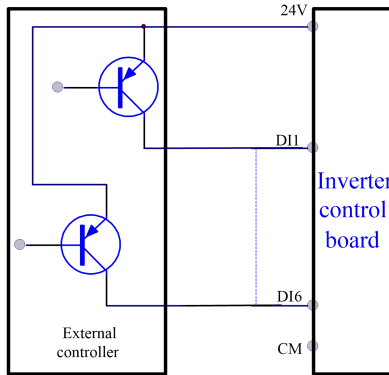

Wiring by source electrode is a mode in common use at present. As factory defaults of control terminals, wiring for control terminal is connected by source electrode, user should choose wiring mode according to requirement.

Instructions of choosing NPN mode or PNP mode:

1. There is a toggle switch J7 near to control terminals. Please refer to Fig 3-5.
2. When turning J7 to “NPN”, DI terminal is connected to CM.
When turning J7 to “PNP”, DI terminal is connected to 24V.



Fig 3-5 Toggle Switch J7

3.5 Measurement of main circuit(voltages, currents and powers)

Since the voltages and currents on the inverter power supply and output sides include high-frequency components, measurement data depends on the instruments used and circuits measured. When commercial frequency instruments are used for measurement, measure the following circuits(Fig3-6) with the recommended instruments(Table 3-3).

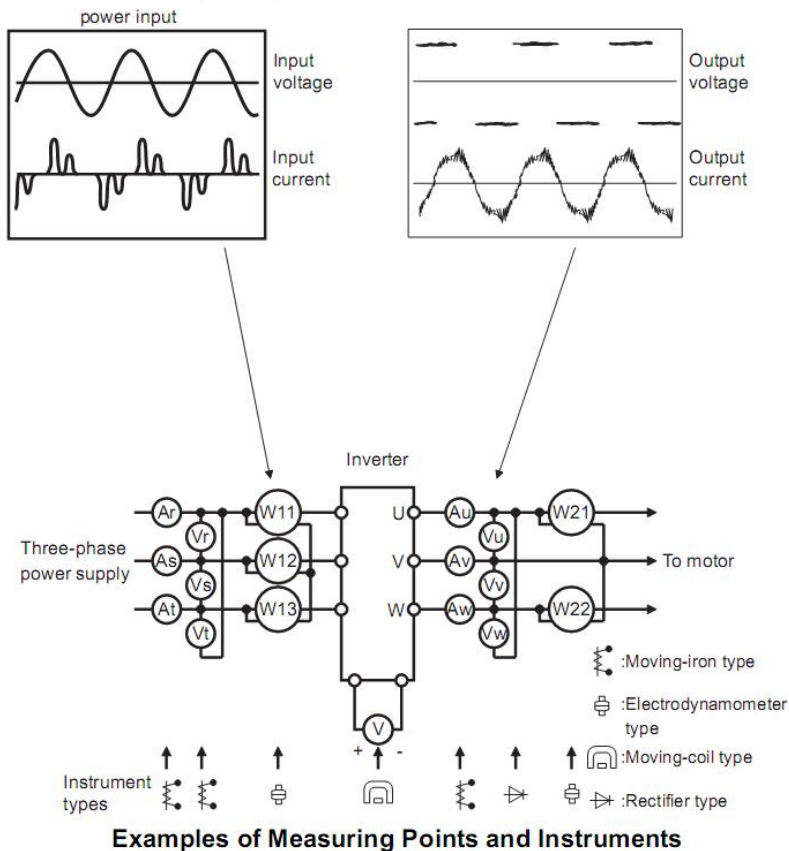

Fig 3-6 Measurement diagram

Table 3-3 Measuring instruments

Item	Measuring Point	Measuring Instrument	Remarks (Reference Measurement Value)
Power supply voltage V1	Across R-S,S-T, T-R	Moving-iron type AC voltmeter	380±15%, 220V±15%
Power supply side current I1	R, S, and T line currents	Moving-iron type AC voltmeter	
Power supply side power P1	At R, S and T, and across R-S, S-T and T-R	Electrodynamics type single-phase wattmeter	P1=W11+W12+W13 (3-wattmeter method)
Power supply side power factor Pfl	Calculate after measuring power supply voltage, power supply side current and power supply side power.[Three phase power supply] $Pfl = \frac{P1}{\sqrt{3}V1 \times I1} \times 100\%$		
Output side voltage V2	Across U-V, V-W and W-U	Rectifier type AC voltmeter (Moving-iron type cannot measure)	Difference between the phases is within ±1% of the maximum output voltage.
Output side current I2	U, V and W line currents	Moving-iron type AC Ammeter	Current should be equal to or less than rated inverter current. Difference between the phases is ±10% or lower of the rated inverter current.
Output side power P2	U, V, W and U-V, V-W,W-U	Electrodynamics' type single-phase wattmeter	P2 = W21 + W22 2-wattmeter method
Output side power factor Pfl2	Calculate in similar manner to power supply side power factor: $Pfl2 = \frac{P2}{\sqrt{3}V2 \times I2} \times 100\%$		
DC bus voltage (Rectifier bridges output)	Across P+ (P) and -(N)	Moving-coil type (such as multi-meter)	DC voltage, the value is $\sqrt{2} \times V1$
Power supply of control PCB	Across 10V-GND	Moving-coil type (such as multi-meter)	DC10V±0.2V
	Across 24V-CM	Moving-coil type (such as multi-meter)	DC24V±1.5V
Analog output AO1	Across AO1-GND	Moving-coil type (such as multi-meter)	Approx. DC10V at max frequency.
Alarm signal	Across TA/TC Across TB/TC	Moving-coil type (such as multi-meter)	<Normal> <Abnormal> Across TA/TC: Discontinuity Continuity Across TB/TC: Continuity Discontinuity

3.6 Wiring Recommended

Inverter Model	LeadSectionArea(mm ²)	Inverter Model	LeadSectionArea(mm ²)
EM30-0004S2	1.5	EM30-0055T2	6.0
EM30-0007S2	2.5	EM30-0007T3	1.5
EM30-0015S2	2.5	EM30-0015T3	2.5
EM30-0022S2	4.0	EM30-0022T3	2.5
EM30-0004T2	1.5	EM30-0030T3	2.5
EM30-0007T2	2.5	EM30-0040T3	2.5
EM30-0015T2	2.5	EM30-0055T3	4.0
EM30-0022T2	4.0	EM30-0075T3	4.0
EM30-0030T2	4.0	EM30-0110T3	6.0
EM30-0040T2	4.0		

3.7 Lead section area of protect conductor (grounding wire)

Lead section area S of U,V,W (mm ²)	Minimum lead section area S of E (mm ²)
$S \leq 16$	S
$16 < S \leq 35$	16
$35 < S$	S/2

3.8 Overall Connection

Refer to the figure below for overall connection sketch for EM30 series inverters. Wiring mode is available for various terminals whereas not every terminal needs connection when applied

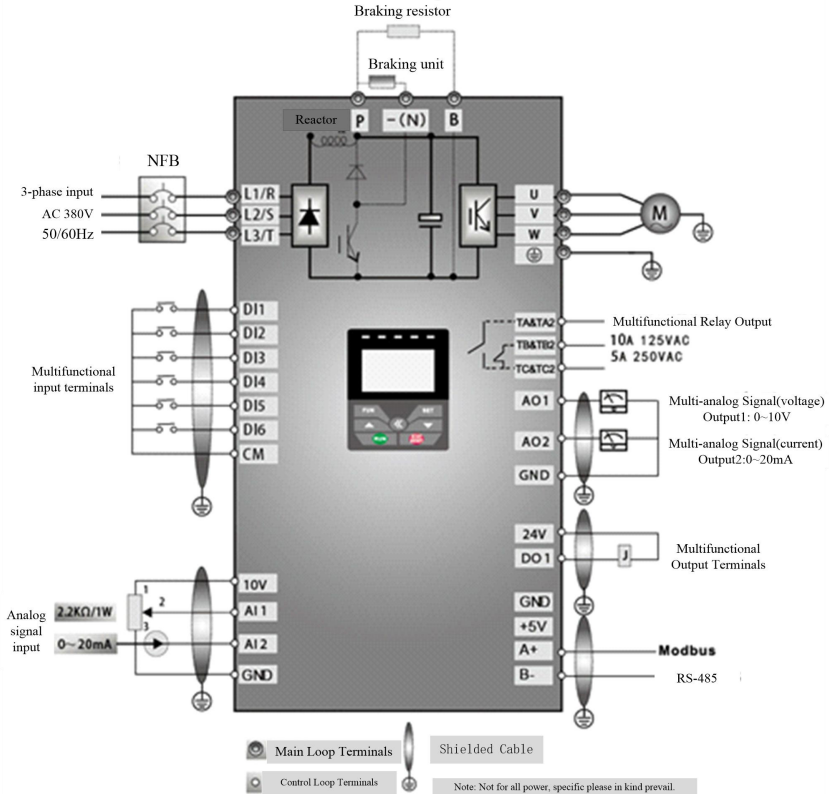

Note:

1. The contact capacity of inverter is 10A/125VAC, 5A/250VAC and 5A/30VDC.

3.9 Solutions of conduction and radiation interference

The noise generated by the drive may disturb the equipment nearby. The degree of disturbance depends on the drive system, immunity of the equipment, wiring, installation clearance and earthing methods.

3.9.1 Noise propagation paths and suppressing methods

① Noise categories

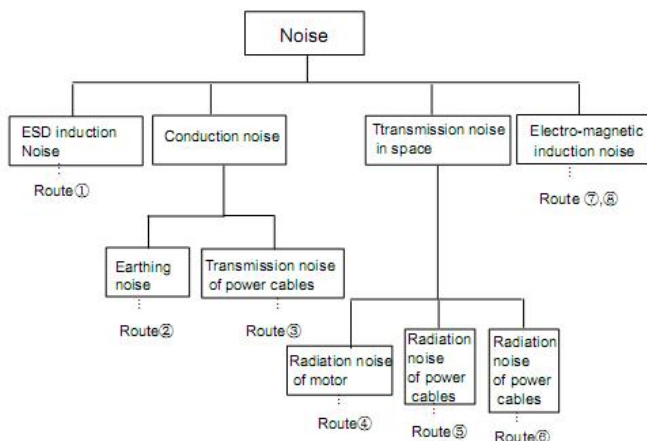

② Noise propagation paths

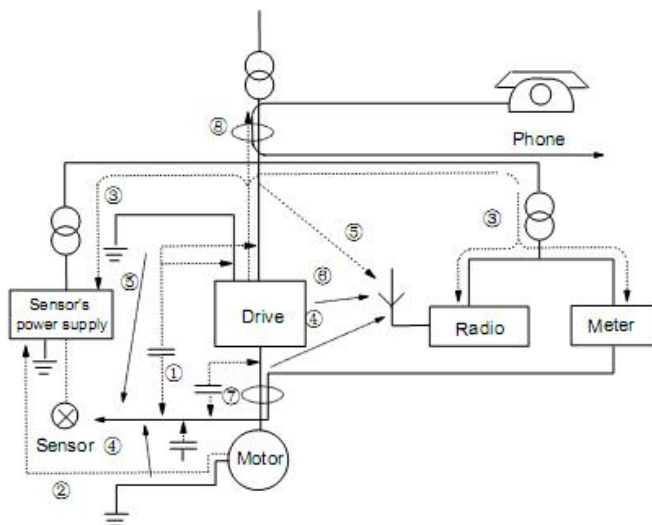

③ Basic methods of suppressing the noise

Noise emission paths	Actions to reduce the noise
②	When the external equipment forms a loop with the drive, the equipment may suffer nuisance tripping due to the drive's earth leakage current. The problem can be solved if the equipment is not grounded.
③	If the external equipment shares the same AC supply with the drive, the drive's noise may transmit along its input power supply cables, which may cause nuisance tripping to other external equipment. Take the following actions to solve this problem: Install noise filter at the input side of the drive, and use an isolation transformer or line filter to prevent the noise from disturbing the external equipment.
④⑤⑥	If the signal cables of measuring meters, radio equipment and sensors are installed in a cabinet together with the drive, these equipment cables will be easily disturbed. Take the actions below to solve the problem: (1) The equipment and the signal cables should be as far away as possible from the drive. The signal cables should be shielded and the shielding layer should be grounded. The signal cables should be placed inside a metal tube and should be located as far away as possible from the input/output cables of the drive. If the signal cables must cross over the power cables, they should be placed at right angle to one another. (2) Install radio noise filter and linear noise filter (ferrite common-mode choke) at the input and output of the drive to suppress the emission noise of power lines. (3) Motor cables should be placed in a tube thicker than 2mm or buried in a cement conduit. Power cables should be placed inside a metal tube and be grounded by shielding layer
①⑦⑧	Don't route the signal cables in parallel with the power cables or bundle these cables together because the induced electro-magnetic noise and induced ESD noise may disturb the signal cables. Other equipment should also be located as far away as possible from the drive. The signal cables should be placed inside a metal tube and should be placed as far away as possible from the input/output cables of the drive. The signal cables and power cables should be shielded cables. EMC interference will be further reduced if they could be placed inside metal tubes. The clearance between the metal tubes should be at least 20cm.

3.9.2 Field Wire Connections

Control cables, input power cables and motor cables should be installed separately, and enough clearance should be left among the cables, especially when the cables are laid in parallel and the cable length is big. If the signal cables must go through the power cables, they should be vertical to each other.

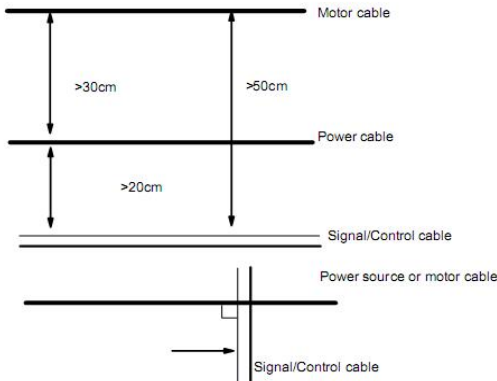

Generally, the control cables should be shielded cables and the shielding metal net must be connected to the metal enclosure of the drive by cable clamps.

3.9.3 Earthing

Independent earthing poles (best)

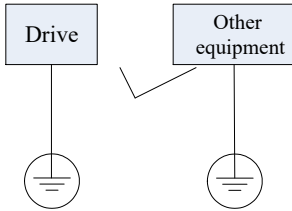

shared earthing pole (good)

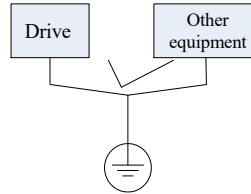

Shared earthing cable (not good)

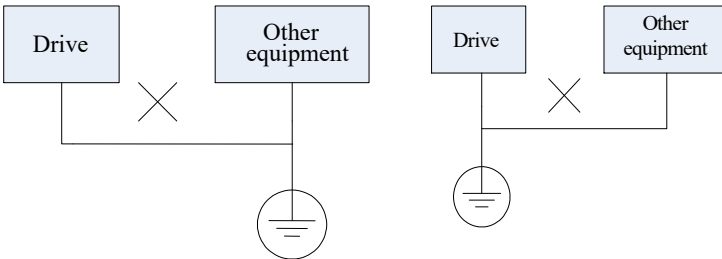

Note:

1. In order to reduce the earthing resistance, flat cable should be used because the high frequency impedance of flat cable is smaller than that of round cable with the same CSA.
2. If the earthing poles of different equipment in one system are connected together, then the leakage current will be a noise source that may disturb the whole system. Therefore, the drive's earthing pole should be separated with the earthing pole of other equipment such as audio equipment, sensors and PC, etc.
3. Earthing cables should be as far away from the I/O cables of the equipment that is sensitive to noise, and also should be as short as possible.

3.9.4 Leakage current and treatment

Leakage current may flow through the drive's input and output capacitors and the motor's capacitor. The leakage current value is dependent on the distributed capacitance and carrier wave frequency. The leakage current includes ground leakage current and the leakage current between lines.

Ground leakage current

The ground leakage current cannot only flow into the drive system, but also other equipment via earthing cables. It may cause the leakage current circuit breaker and relays falsely activated. The higher the drive's carrier wave frequency, the bigger the leakage current, also, the longer the motor cable, the greater the leakage current,

Suppressing methods:

- Reduce the carrier wave frequency, but the motor noise may be louder;
- Motor cables should be as short as possible;
- The drive and other equipment should use leakage current circuit breaker designed for protecting the product against high-order harmonics/surge leakage current;

Leakage current between lines

The line leakage current flowing through the distribution capacitors of the drive outside may cause the thermal relay falsely activated, especially for the drive whose power is lower than 7.5kW. When the cable is longer than 50m, the ratio of leakage current to motor rated current may be increased that can cause the wrong action of external thermal relay very easily.

Suppressing methods:

- Reduce the carrier wave frequency, but the motor noise may become louder;
- Install reactor at the output side of the drive.

In order to protect the motor reliably, it is recommended to use a temperature sensor to detect the motor's temperature, and use the drive's over-load protection device (electronic thermal relay) instead of an external thermal relay.

3.9.5 Electrical installation of the drive

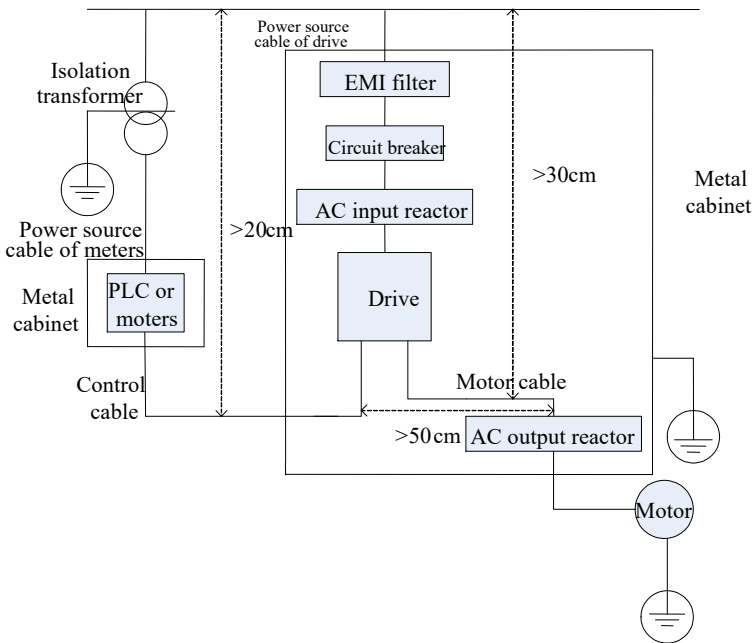

Note:

- Motor cable should be earthed at the drive side, if possible, the motor and drive should be earthed separately;
- Motor cable and control cable should be shielded. The shield must be earthed and avoid entangling at cable end to improve high frequency noise immunity.
- Assure good conductivity among plates, screw and metal case of the drive; use tooth-shape washer and conductive installation plate;

3.9.6 Application of Power Line Filter

Power source filter should be used in the equipment that may generate strong EMI or the equipment that is sensitive to the external EMI. The power source filter should be a two-way low pass filter through which only 50Hz current can flow and high frequency current should be rejected.

Function of power line filter

The power line filter ensures the equipment can satisfy the conducting emission and conducting sensitivity in EMC standard. It can also suppress the radiation of the equipment.

Common mistakes in using power cable filter

1. Too long power cable

The filter inside the cabinet should be located near to the input power source. The length of the power cables should be as short as possible.

2. The input and output cables of the AC supply filter are too close

The distance between input and output cables of the filter should be as far apart as possible, or the high frequency noise may be coupled between the cables and bypass the filter. Thus, the filter will become ineffective.

3. Bad earthing of filter

The filter's enclosure must be earthed properly to the metal case of the drive. In order to be earthed well, make use of a special earthing terminal on the filter's enclosure. If you use one cable to connect the filter to the case, the earthing is useless for high frequency interference. When the frequency is high, so is the impedance of cable, hence there is little bypass effect. The filter should be mounted on the enclosure of equipment. Ensure to clear away the insulation paint between the filter case and the enclosure for good earthing contact.

IV. Operation and Simple Running

This chapter mainly introduces the basic knowledge of our products, related operation procedure and methods. It will be helpful to your correct operation.

4.1 Basic conception

4.1.1 Control mode

EM30 inverter has three control modes: sensorless vector control (F106=0), VVVF control (F106=2), vector control 1 (F106=3) and PMSM sensorless vector control (F106=6).

4.1.2 Torque Compensation Mode

Under VVVF control mode, EM30 inverter has five kinds of torque compensation modes: Linear compensation (F137=0); Square compensation (F137=1); User-defined multipoint compensation (F137=2); Auto torque compensation (F137=3) and V/F separation (F137=4.)

4.1.3 Frequency Setting Mode

Please refer to F203–F207 for the method for setting the running frequency of the EM30 inverter.

4.1.4 Mode of controlling for running command

The channel for inverter to receive control commands (including start, stop and jogging, etc) contains five modes: 0. Keypad (keypad panel) control; 1. External terminal control; 2. MODBUS+Terminal control; 3. MODBUS control; 4. Keypad+Terminal+MODBUS control

The modes of control command can be selected through the function codes F200 and F201.

4.1.5 Operating status of inverter

When the inverter is powered on, there are four kinds of operating status: stopped status, programming status, running status, and fault alarm status. They are described as follows:

1) Stopped status

If re-energize the inverter (if “auto-startup after being powered on” is not set) or decelerate the inverter to stop, the inverter is at the stopping status until receiving control command. At this moment, the running status indicator on the keypad goes off, and the display shows the display status before power down.

2) Programming status

Through keypad panel, the inverter can be switched to the status that can read or change the function code parameters. Such a status is the programming status.

There are numbers of function parameters in the inverter. By changing these parameters, the user can realize different control modes.

3) Running status

The inverter at the stopped status or fault-free status will enter running status after having received operation command.

The running indicator on keypad panel lights up under normal running status.

4) Fault alarm status

The status under which the inverter has a fault and the fault code is displayed.

Fault codes mainly include: OC, OE, OL1, OL2, OH, LU, PF1 and PF0 representing “over current”, “over voltage”, “inverter overload”, “motor overload”, “overheat”, “input under-voltage”, “input phase loss”, and “output phase loss” respectively.

For trouble shooting, please refer to Appendix I to this manual, “Trouble Shooting”.

4.2 Keypad panel and operation method

Keypad panel (keypad) is standard configuration of EM30 inverter. Through keypad panel, the user can carry out parameter setting, status monitoring and operation control over the inverter. Both keypad panel and display screen are arranged on the keypad controller, which mainly consists of three sections: data display section, status indicating section, and keypad operating section.

It is necessary to know the functions and how to use the keypad panel. Please read this manual carefully before operation.

4.2.1 Operation Method of keypad panel

(1) Operation process of setting the parameters through keypad panel



A three-level menu structure is adopted for setting the parameters through keypad panel of inverter, which enables convenient and quick searching and changing of function code parameters.

Three-level menu: Function code group (first-level menu) → Function code (second-level menu) → Set value of each function code (third-level menu).

(2) Setting the parameters

Setting the parameters correctly is a precondition to give full play of inverter performance. The following is the introduction on how to set the parameters through keypad panel.

Operating procedures of keypad panel:

- a. Press the “Fun” key, to enter programming menu.
- b. Press  the key, and ▲ and ▼ key, the function code will change within the function code group. The first number behind F displayed on the panel is 1, in other words, it displays F1××at this moment. Press ▲ and ▼ key, function code will change between FIXX to FCXX.
- c. Press the key  again, the function code will change within the code group. Press ▲ and ▼ to change the function code to F113; press the “Set” key to display 50.00; while press ▲ and ▼ to change to the need frequency.
- d. Press the “Set” key to complete the change.

4.2.2 Switching and displaying of status parameters

Under stopped status or running status, status parameters of the inverter can be displayed. Actual parameters displayed can be selected and set through function codes F131 and F132. Through the  key, it can switch over repeatedly and display the parameters of stopped status or running status. The followings are the description of operation method of displaying the parameters under stopped status and running status.

(1) Switching of the parameters displayed under stopped status

Under stopped status, inverter has five parameters of stopped status, which can be switched over repeatedly and displayed with the keys “Fun”. These parameters are displaying: keypad jogging, target rotary speed, PN voltage, PID feedback value, and temperature. Please refer to the description of function code F132.

(2) Switching of the parameters displayed under running status

Under running status, eight parameters of running status can be switched over repeatedly and displayed with the keys “Fun”. These parameters are displayed: output frequency, output rotary speed, output current, output voltage, PN voltage, PID feedback value, temperature, PID given value and linear speed. Please refer to the description of function code F131.

4.2.3 Operation process of measuring motor parameters

The user shall input the parameters accurately as indicated on the nameplate of the motor prior to selecting auto torque compensation of VVVF control mode. Inverter will match standard motor stator resistance parameters according to these parameters indicated on the nameplate. To achieve better control performance, the user may start the inverter to measure the motor stator resistance parameters, so as to obtain accurate parameters of the motor controlled.

The motor parameters can be tuned through function code F800.

For example: If the parameters indicated on the nameplate of the motor controlled are as follows: numbers of motor poles are 4; rated power is 7.5kW; rated voltage is 400V; rated current is 15.4A; rated frequency is 50.00HZ; and rated rotary speed is 1440rpm, operation process of measuring the parameters shall be done as described in the following:

1. In accordance with the above motor parameters, set the values of F801 to F805 correctly: set the value of F801 = 7.5, F802 = 400, F803 = 15.4, F804 = 4 and F805 = 1440 respectively.
2. In order to ensure dynamic control performance of the inverter, set F800=1, i.e. select rotating tuning. Make sure that the motor is disconnected from the load. Press the "Run" key on the keypad, and the inverter will display "TEST", and it will tune the motor's parameters of two stages. After that, the motor will accelerate according to the acceleration time set at F114 and maintain for a certain period. The speed of motor will then decelerate to 0 according to the time set at F115. After auto-checking is completed, relevant parameters of the motor will be stored in function codes F806-F809, and F800 will turn to 0 automatically.
3. If it is impossible to disconnect the motor from the load, select F800=2, i.e. stationary tuning. Press the "Run" key, the inverter will display "TEST...", and it will tune the motor's parameters of two stages. The motor's stator resistance, rotor resistance and leakage inductance will be stored in F806-F808 automatically, and F800 will turn to 0 automatically. The user may also calculate and input the motor's mutual inductance value manually according to actual conditions of the motor.

4.2.4 Operation process of simple running

Table 4-1 Brief Introduction to Inverter Operation Process

Process	Operation	Reference
Installation and operation environment	Install the inverter at a location meeting the technical specifications and requirements of the product. Mainly take into consideration the environment conditions (temperature, humidity, etc) and heat radiation of the inverter, to check whether they can satisfy the requirements.	See Chapters I, II, III.
Wiring of the inverter	Wiring of input and output terminals of the main circuit; wiring of grounding; wiring of switching value control terminal, analog terminal and communication interface, etc.	See Chapter III.
Checking before getting energized	Make sure that the voltage of input power supply is correct; the input power supply loop is connected with a breaker; the inverter has been grounded correctly and reliably; the power cable is connected to the power supply input terminals of inverter correctly (L1, L2/N terminals for single-phase power grid, and R/L1, S/L2, and T/L3 for three-phase power grid); the output terminals U, V, and W of the inverter are connected to the motor correctly; the wiring of control terminals is correct; all the external switches are preset correctly; and the motor is under no load (the mechanical load is disconnected from the motor).	See Chapters I, II, III
Checking immediately after energized	Check if there is any abnormal sound, fuming or foreign flavor with the inverter. Make sure that the display of keypad panel is normal, without any fault alarm message. In case of any abnormality, switch off the power supply immediately.	See Appendix 1
Inputting the parameters indicated on the motor's nameplate correctly, and measuring the motor's parameters.	Make sure to input the parameters indicated on the motor nameplate correctly, and study the parameters of the motor. The users shall check carefully, otherwise, serious problems may arise during running. Before initial running with vector control mode, carry out tuning of motor parameters, to obtain accurate electric parameters of the motor controlled. Before carrying out tuning of the parameters, make sure to disconnect the motor from mechanical load, to make the motor under entirely no load status. It is prohibited to measure the parameters when the motor is at a running status.	See description of parameter group F800-F830
Setting running control parameters	Set the parameters of the inverter and the motor correctly, which mainly include target frequency, upper and lower frequency limits, acceleration/deceleration time, and direction control command, etc. The user can select corresponding running control mode according to actual applications.	See description of parameter group.
Checking under trail run with no load	With the motor under no load, start the inverter with the keypad or control terminal. Check and confirm running status of the drive system. Motor's status: stable running, normal running, correct rotary direction, normal acceleration/deceleration process, free from abnormal vibration, abnormal noise and foreign flavor. Inverter status: normal display of the data on keypad panel, normal running of the fan, normal acting sequence of the relay, free from the abnormalities like vibration or noise. In case of any abnormality, stop and check the inverter immediately.	See Chapter IV.

<p>Checking under trail run with load</p>	<p>After successful test run under no load, connect the load of drive system properly. Start the inverter with the keypad or control terminal, and increase the load gradually. When the load is increased to 50% and 100%, keep the inverter run for a period respectively, to check if the system is running normally. Carry out overall inspection over the inverter during running, to check if there is any abnormality. In case of any abnormality, stop and check the inverter immediately.</p>	
<p>Checking during running</p>	<p>Check if the motor is running stably, if the rotary direction of the motor is correct, if there is any abnormal vibration or noise when the motor is running, if the acceleration/deceleration process of the motor is stable, if the output status of the inverter and the display of keypad panel is correct, if the blower fan is run normally, and if there is any abnormal vibration or noise. In case of any abnormality, stop the inverter immediately, and check it after switching off the power supply.</p>	

4.3 Illustration of basic operation

Illustration of inverter basic operation: we hereafter show various basic control operation processes by taking a 7.5kW inverter that drives a 7.5kW three-phase asynchronous AC motor as an example in fig 4-1.

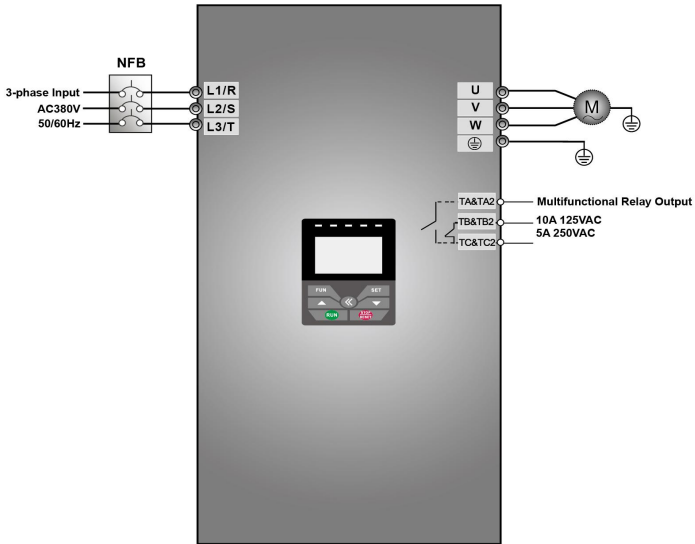

Figure 4-1 Wiring Diagram 1

The parameters indicated on the nameplate of the motor are as follows: 4 poles; rated power, 7.5kW; rated voltage, 400V; rated current, 15.4A; rated frequency 50.00HZ; and rated rotary speed, 1440rpm.

4.3.1 Operation process of frequency setting, start, forward running and stop with keypad panel

- (1) Connect the wires in accordance with Figure 4-1. After having checked the wiring successfully, switch on the air switch, and power on the inverter.
- (2) Press the “Fun” key, to enter the programming menu.
- (3) Measure the parameters of the motor.

Function code	Values
F800	1(2)
F801	7.5
F802	400
F803	15.4
F805	1440
F810	50.00

Press the “Run” key, to measure the parameters of the motor. After completion of the tuning, the motor will stop running, and relevant parameters will be stored in F806~F809. For the details of tuning of motor parameters, please refer to “Operation process of measuring the motor parameters” in this manual and Chapter XII of this manual. (Note: F800=1 is rotating tuning, F800=2 is stationary tuning. In the mode of rotating tuning, make sure to disconnect the motor from the load).

- (4) Set functional parameters of the inverter:

Function code	Values
F111	50.00
F200	0
F201	0
F202	0
F203	0

- (5) Press the “Run” key, to start the inverter;
- (6) During running, current frequency of the inverter can be changed by pressing ▲ or ▼;
- (7) Press the “STOP/RESET” key once, the motor will decelerate until it stops running;
- (8) Switch off the air switch, and power off the inverter.

4.3.2 Operation process of setting the frequency with keypad panel, and starting, forward and reverse running, and stopping inverter through control terminals

- (1) Connect the wires in accordance with Figure 4-2. After having checked the wiring successfully, switch on the air switch, and power on the inverter;

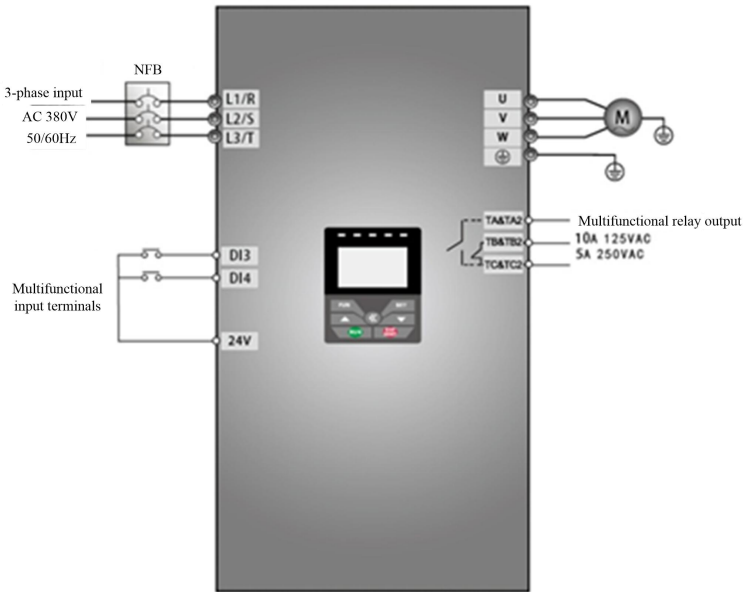

Figure 4-2 Wiring Diagram 2(PNP)

- (2) Press the “Fun” key, to enter the programming menu.
- (3) Study the parameters of the motor: the operation process is the same as that of example 1.
- (4) Set functional parameters of the inverter:

Function code	Values
F111	50.00
F203	0
F208	1

- (5) Close the switch DI3, the inverter starts forward running;
- (6) During running, current frequency of the inverter can be changed by pressing ▲ or ▼;
- (7) During running, switch off the switch DI3, then close the switch DI4, the running direction of the motor will be changed (Note: The user should set the dead time of forward and reverse running F120

on the basis of the load. If it was too short, OC protection of the inverter may occur.)

- (8) Switch off the switches DI3 and DI4, the motor will decelerate until it stops running;
- (9) Switch off the air switch, and power off the inverter.

4.3.3 Operation process of setting the frequency with analog terminal and controlling the operation with control terminals

- (1) Connect the wires in accordance with Figure 4-3. After having checked the wiring successfully, switch on the air switch, and power on the inverter.

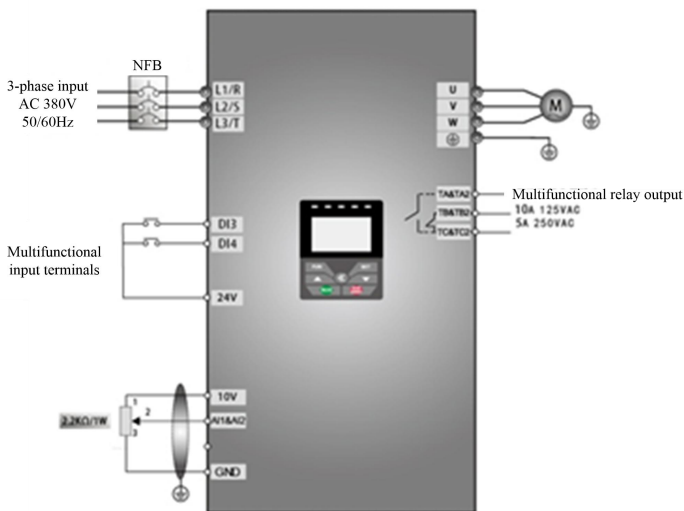

Figure 4-3 Wiring Diagram 3(PNP)

- (2) Press the “Fun” key, to enter the programming menu.
- (3) Study the parameters of the motor: the operation process is the same as that of example 1.
- (4) Set functional parameters of the inverter:

Function code	Values
F203	1
F208	1

- (5) There is a red four-digit coding switch SW1 near the control terminal block of EM30 series, as shown in Figure 4-4. The function of coding switch is to select the analog input terminals AI1 and AI2, input range(0~5V/0~10V/0~20mA); In actual application, select the analog input channel through F203. The position of factory coding switch is showed in fig 4-4, AI1: 0~10V input, AI2: 0~20mA input; Another switches states and mode of control speed are as table 4-2.
- (6) Close the switch DI3, the motor starts forward running;
- (7) The potentiometer can be adjusted and set during running, and the current setting frequency of the

- inverter can be changed;
- (8) During running process, switch off the switch DI3, then, close DI4, the running direction of the motor will be changed;
 - (9) Switch off the switches DI3 and DI4, the motor will decelerate until it stops running;
 - (10) Switch off the air switch, and power off the inverter.
- (11) There are two analog output terminals AO1 and AO2, both terminals can output voltage signal and current signal, the selecting switch of voltage/current is J5, the position of factory toggle switch is showed as below in Fig 4-5, AO1=V, AO2=I, the output relation is shown in table 4-3.

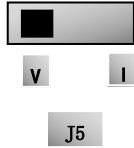
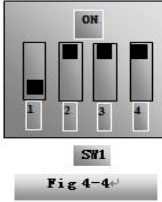

Fig 4-5

Table 4-2 The Setting of Coding Switch and Parameters in the Mode of Analog Speed Control

Set F203=1, to select channel AI1				Set F203=2, to select channel AI2		
Coding Switch SW1		Toggle switch S1	Analog signal range	Coding Switch SW1		
Switch 1	Switch 3			Switch 2	Switch 4	Analog signal range
OFF	OFF	+	0~5V voltage	OFF	OFF	0~5V voltage
OFF	ON	+	0~10V voltage	OFF	ON	0~10V voltage
ON	OFF	+	0~20mA current	ON	OFF	0~20mA current

ON refers to switching the coding switch to the top, OFF refers to switching the coding switch to the bottom

Table 4-3 The relationship between AO1 and J5 and F423/F427:

AO1 output		Setting of F423/F427		
		0	1	2
J5	V	0~5V	0~10V	Reserved
	I	Reserved	0~20mA	4~20mA

V. Function Parameters

5.1 Basic parameters

F100	User's Password	Setting range: 0~9999	Mfr's value: 0
------	-----------------	-----------------------	----------------

·When F107=1 with valid password, the user must enter correct user's password after power on or fault reset if you intend to change parameters. Otherwise, parameter setting will not be possible, and a prompt "Err1" will be displayed.

Relating function code: F107 Password valid or not F108 Setting user's password

F102	Inverter's Rated Current (A)		Mfr's value: Subject to inverter model
F103	Inverter Power (kW)		Mfr's value: Subject to inverter model

· Rated current and rated power can only be checked but cannot be modified.

F105	Software Edition No.	Setting range: 1:00~10.00	Mfr's value: Subject to inverter model
------	----------------------	---------------------------	--

Software Edition No. can only be checked but cannot be modified.

F106	Control mode	Setting range: 0: Sensorless vector control (SVC); 2: V/F control; 3: Vector control 1; 4~5: Reserved; 6: PMSM sensorless vector control	Mfr's value: 2
------	--------------	---	----------------

0: Sensorless vector control is suitable for the application of high-performance requirement. One inverter can only drive one motor.

2: V/F control is suitable for common requirement of control precision or one inverter drives several motors.

3: Vector control 1 is auto torque promotion, which has the same function of F137=3. While studying motor parameters, motor does not need to be disconnected with load. One inverter can only drive one motor.

6: PMSM sensorless vector control is suitable for the application of high-performance requirement. One inverter can only drive one motor.

Note:

1. It is necessary to study the parameters of motor before inverter runs in the sensorless vector control (F106=0 or 3 or 6).
2. Under sensorless vector control (F106=0 or 3 or 6), one inverter can only drive one motor and the power of motor should be similar to the power of inverter. Otherwise, control performance will be decreased or system cannot work properly.
3. The operator may input motor parameters manually according to the motor parameters given by motor manufacturer.
4. Generally, the motor will work normally by inverter's default parameters, but the inverter's best control performance will not be acquired. Therefore, in order to get the best control performance, please study the parameters of motor before inverter runs in the sensorless vector control.

F107 Password Valid or Not	Setting range: 0: Invalid; 1: Valid 2. Invalid for Modbus 3. Enable lockscreen	Mfr's value: 0
F108 Setting User's Password	Setting range: 0~9999	Mfr's value: 8

·When F107=0, the parameter can be changed without inputting the password

· When F107=1, the parameter can be changed only after inputting the user's password by F100.

When F107=2, the parameter can be change by PC/PLC through communication.

When F107=3, the parameter can be read only after inputting the user's password by F100.

·The user can change "User's Password". The operation process is the same as those of changing other parameters.

· Input the value of F108 into F100, and the user's password can be unlocked.

Note: When password protection is valid, and if the user's password is not entered, F108 will display 0.

F109 Starting Frequency (Hz)	Setting range: 0.00~10.00	Mfr's value: 0.00
F110 Holding Time of Starting Frequency (S)	Setting range: 0.0~999.9	Mfr's value: 0.0

·The inverter begins to run from the starting frequency. If the target frequency is lower than starting frequency, F109 is invalid.

·The inverter begins to run from the starting frequency. After it keeps running at the starting frequency for the time as set in F110, it will accelerate to target frequency. The holding time is not included in acceleration/deceleration time.

·Starting frequency is not limited by the Min frequency set by F112. If the starting frequency (F109) is lower than Min frequency set by F112, inverter will start according to the setting parameters set by F109 and F110. After inverter starts and runs normally, the frequency will be limited by frequency set by F111 and F112.

·Starting frequency should be lower than Max frequency set by F111.

·F109 and F110 are invalid when speed track.

F111 Max Frequency (Hz)	Setting range: F113~590.0	Mfr's value: 50.00
F112 Min Frequency (Hz)	Setting range: 0.00~F113	Mfr's value: 0.50

· Max frequency is set by F111.

Note: The max frequency is not allowed to higher than 500Hz under the vector mode (F106=0, 1).

· Min frequency is set by F112.

· The setting value of min frequency should be lower than target frequency set by F113.

· The inverter begins to run from the starting frequency. During inverter running, if the given frequency is lower than min frequency, then inverter will run at min frequency until inverter stops or given frequency is higher than min frequency.

Max/Min frequency should be set according to the nameplate parameters and running situations of motor. The motor is forbidden running at low frequency for a long time, or else motor will be damaged because of overheat.

F113 Target Frequency (Hz)	Setting range: F112~F111	Mfr's value: 50.00
----------------------------	--------------------------	--------------------

·It shows the preset frequency. The value is the Mfr's value of the target frequency when setting the main frequency source as "digital setting". Under keypad speed control or terminal speed control mode, the inverter will run to this frequency automatically after startup.

E.g. Remain the factory defaults unchanged after power on, then press "RUN" key on keypad, so the inverter will run from 0Hz to 50Hz(default value of target frequency).

F114 First Acceleration Time (S)	Setting range: 0.1~3000	Mfr's value: subject to inverter model
F115 First Deceleration Time (S)		
F116 Second Acceleration Time (S)		
F117 Second Deceleration Time (S)		

· F119 is used as the reference of setting accel/decel time.

· The second Acceleration/Deceleration time can be chosen by setting multifunction digital input terminals F316~F323 to make value 18 and connecting DI terminal with CM terminal. Please refer to the instructions of

multi-functional input terminals.

Note: when speed track is working, acceleration/deceleration time, min frequency and target frequency are invalid. After speed track is finished, inverter will run to target frequency according to acceleration/deceleration time.

F119	The reference of setting accel/decel time	Setting range: 0: 0~50.00Hz 1: 0~max frequency 2: 0~ target frequency	Mfr's value: 0
------	---	---	----------------

When F119=0, acceleration/ deceleration time means the time for inverter to accelerate/ decelerate from 0Hz (50Hz) to 50Hz (0Hz).

When F119=1, acceleration/ deceleration time means the time for inverter to accelerate/ decelerate from 0Hz (max frequency) to max frequency (0Hz).

When F119=2, acceleration/ deceleration time means the time for inverter to accelerate/ decelerate from 0Hz (max frequency) to target frequency (0Hz).

F120	Forward / Reverse Switchover dead-Time (S)	Setting range: 0.0~3000	Mfr's value: 0.00
------	--	-------------------------	-------------------

· Within “forward/ reverse switchover dead-time”, this latency time will be cancelled and the inverter will switch to run in the other direction immediately upon receiving “stop” signal. This function is suitable for all the speed control modes except automatic cycle operation.

· This function can ease the current impact in the process of direction switchover.

Note: during the process of speed track, F120 is invalid. After speed track is finished, this function code is valid.

F121	VF Torque Compensation	Setting range: 0: Invalid 1: Valid	Mfr's value: 0
------	------------------------	------------------------------------	----------------

· It is to increase output torque at VF control. Please make sure of motor autotuning before using it.

Note: Please do not use this function when one inverter runs with more motor.

F122	Reverse Running Forbidden	Setting range: 0: invalid; 1: valid	Mfr's value: 0
------	---------------------------	--	----------------

When F122=1, inverter will only run forward no matter the state of terminals and the parameters set by F202. Inverter will not run reverse and forward / reverse switchover is forbidden. If reverse signal is given, inverter will stop.

If reverse running locking is valid (F202=1), whatever speed track is valid or not, inverter has no output.

When F122=1, F613=1 and inverter gets forward running command and motor is sliding reverse, if inverter can detect the sliding direction and track to motor speed, then inverter will run to 0.0Hz reverse, then run forward according to the setting value of parameters.

F123	Negative frequency allowed in the mode of combined speed control.	0: Invalid; 1: valid	Mfr's value: 0
------	---	-------------------------	----------------

· In the mode of combined speed control, if running frequency is negative and F123=0, inverter will run at 0Hz; if F123=1, inverter will run reverse at this frequency. (This function is controlled by F122.)

F124	Jogging Frequency (Hz)	Setting range: F112~F111	Mfr's value: 5.00
F125	Jogging Acceleration Time (S)	Setting range: 0.1~3000	Mfr's value: subject to inverter model
F126	Jogging Deceleration Time (S)		

· In the case of terminal jogging, make “jogging” terminal (such as DI1) connected to CM, and inverter will run to jogging frequency. The rated function codes are from F316 to F323.

Note: when jogging function is valid, speed track function is invalid.

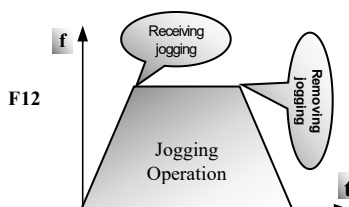

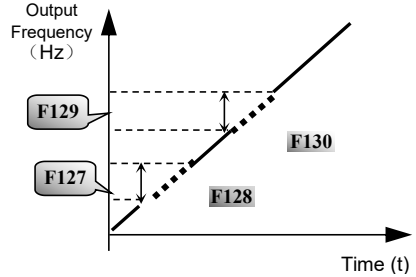

Figure 5-2 Skip Frequency

F127/F129	Skip Frequency A,B (Hz)	Setting range: 0.00~590.0	Mfr's value:0.00
F128/F130	Skip Width A,B (Hz)	Setting range:0~2.50	Mfr's value: 0.0

· Systematic vibration may occur when the motor is running at a certain frequency. This parameter is set to skip this frequency.

·The inverter will skip the point automatically when output frequency is equal to the set value of this parameter.

·“Skip Width” is the span from the upper to the lower limits around Skip Frequency. For example, Skip Frequency=20Hz, Skip Width=±0.5Hz, inverter will skip automatically when output is between 19.5 ~ 20.5Hz.

When F226=0, inverter will not skip this frequency span during acceleration/deceleration. Please refer to F226 for frequency avoidance mode.

Note: During the process of speed track, skip frequency function is invalid. After speed track is finished, this function is valid.

F131	Running Display Items	0—Current output frequency/function-code 1—Output rotary speed 2—Output current 4—Output voltage 8—PN voltage 16—PID feedback value 32—Temperature 64—Count values 128—Linear speed 256—PID set value 2048—Output power 4096— Output torque	Mfr's value: 0+1+2+4+8=15
------	-----------------------	--	------------------------------

·Selection of one value from 1, 2, 4, 8, 16, 32, 64 and 128 shows that only one specific display item is selected. Should multiple display items be intended, add the values of the corresponding display items and take the total values as the set value of F131, e.g., just set F131 to be 19 (1+2+16) if you want to call “current output rotary speed”, “output current” and “PID feedback value”. The other display items will be covered.

·As F131=8191, all display items are visible, of which, “frequency/function-code” will be visible whether it is selected or not.

·If user intend to check any the display content, press  key to check them.

·Whatever the value of F131 is set to, corresponding target frequency will flash under stopped status.

Note: when count value is displayed and it exceeds 9999, only 4 digits are displayed and add a decimal point to it, i.e. 12345 is displayed as the form of 1234. .

F132	Display items of stop	Setting range: 0: Frequency/function-code 2: Target rotary speed 4: PN voltage 8: PID feedback value 16: Temperature 32: Count value 64: PID given value 512: Setting torque	Mfr's value: 0+2+4=6
------	-----------------------	--	-------------------------

Note: The setting and displaying of F132 is the same as F131.

F133	Drive ratio of driven system	Setting range: 0.10~200.0	Mfr's value: 1.00
F134	Transmission-wheel radius	0.001~1.000 (m)	Mfr's value: 0.001

·Calculation of rotary speed and linear speed:

For example, If inverter's max frequency F111=50.00Hz, pole numbers of motor F804=4, drive ratio F133=1.00, transmission-shaft radius R=0.05m, then

Transmission shaft perimeter: $2\pi r=2\times 3.14\times 0.05=0.314$ (meter)

Transmission shaft rotary speed: $60\times \text{operation frequency}/(\text{numbers of poles pairs} \times \text{drive ratio})=60\times 50/(2\times 1.00)=1500\text{rpm}$

Endmost linear speed: $\text{rotary speed} \times \text{perimeter}=1500\times 0.314=471(\text{meters/second})$

F135	User macro	Setting range: 0: Invalid 1: user macro 1 2: user macro 2	Mfr's value: 0
------	------------	--	----------------

When F135=0, user macro parameters are not saved.

When F135=1, all setting parameters are saved in user macro 1.

When F135=2, all setting parameters are saved in user macro 2.

After macro is saved, user can check macro by setting F160=21 or F160=22

F136	Slip compensation	Setting range: 0~10	Mfr's value: 0
------	-------------------	---------------------	----------------

·Under V/F control mode, rotary speed of motor rotor will decrease as load increases. Be assured that rotor rotate speed is near to synchronization rotary speed while motor with rated load, slip compensation should be adopted according to the setting value of frequency compensation.

Note: during the process of speed track, slip compensation function is invalid. After speed track is finished, this function is valid.

F137	Modes of torque compensation	Setting range: 0: Linear compensation; 1: Square compensation; 2: User-defined multipoint compensation 3: Auto torque compensation 4: V/F separation	Mfr's value: 0
------	------------------------------	---	----------------

F138	Linear compensation	Setting range: 1~20	Mfr's value: subject to inverter model
F139	Power compensation	Setting range: 1: the power of 1.5 2: the power of 1.8 3: the power of 1.9 4: the 2nd power 5、 6: Reserved	Mfr's value: 1

When F106=2, the function of F137 is valid.

To compensate low-frequency torque controlled by VVVF, output voltage of inverter while low-frequency should be compensated.

When F137=0, linear compensation is chosen and it is applied on universal constant-torque load;

When F137=1, square compensation is chose and it is applied on the loads of fan or water pump;

When F137=2, user-defined multipoint compensation is chosen and it is applied on the special loads of spin-drier or centrifuge;

This parameter should be increased when the load is heavier, and this parameter should be decreased when the load is lighter.

If the torque is elevated too much, motor is easy to overheat, and the current of inverter will be too high. Please check the motor while elevating the torque.

When F137=3, auto torque compensation is chose and it can compensate low-frequency torque automatically, to diminish motor slip, to make rotor rotary speed close to synchro rotary speed and to restrain motor vibration. Customers should set correctly motor power, rotary speed, numbers of motor poles, motor rated current and stator resistance. Please refer to the chapter "Operation process of measuring motor parameters".

When F137=4, output voltage is not related to output frequency, output frequency is controlled by frequency source, and output voltage is controlled by F671.

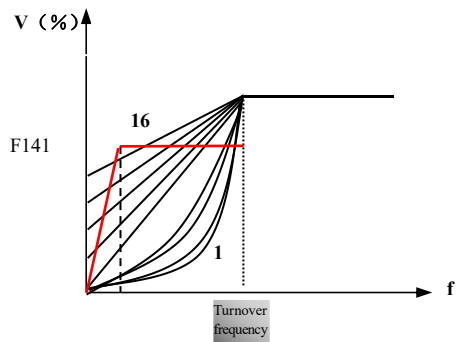

Fig 5-3 Torque Promotion

F140	Voltage compensation point frequency (Hz)	Setting range: 0.00~F142	Mfr's value: 1.00
F141	Voltage compensation point 1 (%)	Setting range: 0~30	Mfr's value: subject to model
F142	User-defined frequency point F2 (Hz)	Setting range: F140~F144	Mfr's value: 5.00
F143	User-defined voltage point V2 (%)	Setting range: 0~100	Mfr's value: 13
F144	User-defined frequency point F3 (Hz)	Setting range: F142~F146	Mfr's value: 10.00
F145	User-defined voltage point V3 (%)	Setting range: 0~100	Mfr's value: 24

F146	User-defined frequency point F4 (Hz)	Setting range: F144~F148	Mfr's value: 20.00
F147	User-defined voltage point V4 (%)	Setting range: 0~100	Mfr's value: 45
F148	User-defined frequency point F5 (Hz)	Setting range: F146~F150	Mfr's value: 30.00
F149	User-defined voltage point V5 (%)	Setting range: 0~100	Mfr's value: 63
F150	User-defined frequency point F6 (Hz)	Setting range: F148~F810	Mfr's value: 40.00
F151	User-defined voltage point V6 (%)	Setting range: 0~100	Mfr's value: 81

As shown in Fig5-3, when F317=0, VF curve compensation =Max (F138, F141)

When F317=1, VF curve compensation =Max (F139, F141)

When F317=2, VF curve compensation =Max (Custom compensation, F141)

When F317=3, auto compensation.

F141 cannot be set too high; otherwise, inverter will easily trip into OH and OC.

Multi-stage V/F curves are defined by 12 parameters from F140 to F151.

The setting value of VVVF curve is set by motor load characteristic.

Note: $V1 < V2 < V3 < V4 < V5 < V6$, $F1 < F2 < F3 < F4 < F5 < F6$. As low-frequency, if the setting voltage is too high, motor will overheat even damaged. Inverter will be OC stalling or occur over-current protection.

Note: during the process of speed track, polygonal-line V/F curve function is invalid. After speed track is finished, this function is valid.

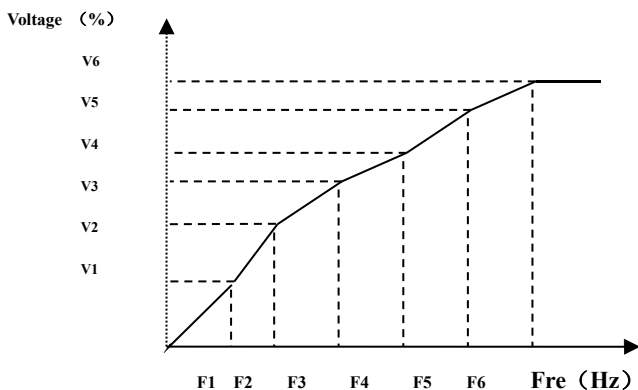

Fig 5-4 Polygonal-Line Type VF

F152 Output voltage corresponding to corner frequency	Setting range: 10~100	Mfr's value: 100
---	-----------------------	------------------

This function can meet the needs of some special loads, for example, when the frequency outputs 300Hz and corresponding voltage outputs 200V (supposed voltage of inverter power supply is 380V), motor rated frequency F810 should be set to 300Hz and F152 is set to $(200 \div 380) \times 100 = 52.6$. And F152 should be equal to 53.

Please pay attention to nameplate parameters of motor. If the working voltage is higher than rated voltage or the frequency is higher than rated frequency, motor would be damaged.

F153	Carrier frequency setting	Setting range: subject to inverter model	Mfr's value: subject to inverter model
------	---------------------------	---	---

Carrier-wave frequency of inverter is adjusted by setting this code function. Adjusting carrier-wave could reduce motor noise; avoid point of resonance of mechanical system, decrease leakage current of wire to earth and the interference of inverter.

When carrier-wave frequency is low, although carrier-wave noise from motor will increase, the current leaked to the earth will decrease. The wastage of motor and the temperature of motor will increase, but the temperature of inverter will decrease.

When carrier-wave frequency is high, the situations are opposite, and the interference will raise.

When output frequency of inverter is adjusted to high frequency, the setting value of carrier-wave should be increased. Performance is influenced by adjusting carrier-wave frequency as below table:

Carrier-wave frequency	Low → High
Motor noise	Loud → Low
Waveform of output	Bad → Good
Motor temperature	High → Low
Inverter temperature	Low → High
Leakage current	Low → High
Interference	Low → High

Derating use is need if carrier frequency is adjusted to more than 10k. Refer to derating list below:

Power	Carrier Frequency						
	10K	11K	12K	13K	14K	15K	16K
0.4	100%	85%	80%	75%	70%	65%	60%
0.75	100%	80%	75%	70%	60%	55%	50%
1.5	100%	85%	80%	75%	70%	65%	60%
2.2	100%	81%	76%	71%	61%	56%	51%
3	100%	80%	75%	70%	60%	55%	50%
4	100%	85%	80%	75%	70%	65%	60%
5.5	100%	81%	76%	71%	61%	56%	51%
7.5	100%	80%	75%	70%	60%	55%	50%

F154 Automatic voltage rectification	Setting range: 0: Disabled 1: Enabled 2: Disabled only in deceleration process	Mfr's value: 0
---	---	----------------

This function is enable to keep output voltage constant automatically in the case of fluctuation of input voltage, but the deceleration time will be affected by internal PI adjustor. If deceleration time is forbidden being changed, please select F154=2.

F155	Digital accessorial frequency setting(Hz)	Setting range: 0~F111	Mfr's value: 0
F156	Digital accessorial frequency polarity setting	Setting range: 0~1	Mfr's value: 0

F157	Reading accessorial frequency		
F158	Reading accessorial frequency polarity		

Under combined speed control mode, when accessorial frequency source is digital setting memory (F204=0), F155 and F156 are considered as initial set values of accessorial frequency and polarity (direction).

In the mode of combined speed control, F157 and F158 are used for reading the value and direction of accessorial frequency.

For example, when F203=1, F204=0, F207=1, the given analog frequency is 15Hz; inverter is required to run to 20Hz. In case of this requirement, user can push "UP" button to raise the frequency from 15Hz to 20Hz. User can also set F155=5Hz and F160=0 (0 means forward, 1 means reverse). In this way, inverter can run to 20Hz directly.

F159	Random carrier-wave selection	Setting range: 0: Control speed normally(prohibited) 1: Random carrier-wave frequency(allowed)	Mfr's value: 1
------	-------------------------------	--	-------------------

When F159=0, inverter will modulate as per the carrier-wave set by F153. When F159=1, inverter will operate in mode of random carrier-wave modulating.

Note: when random carrier-wave is selected, output torque will increase but noise will be loud. When the carrier-wave set by F153 is selected, noise will be reduced, but output torque will decrease. Please set the value according to the situation.

F160	Reverting to manufacturer values	Setting range: 0: Not reverting to manufacture value 1: Reverting to manufacturer value	Mfr's value: 0
------	----------------------------------	---	----------------

- When there is disorder with inverter's parameters and manufacturer values need to be restored, set F160=1. After "Reverting to manufacturer values" is done, F160 values will be automatically changed to 0.
- "Reverting to manufacturer values" will not work for the function-codes marked "o" in the "change" column of the parameters table. These function codes have been adjusted properly before delivery. And it is recommended not to change them.

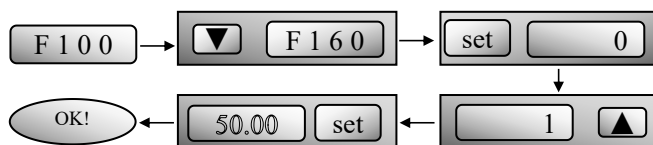

Figure 5-5 Reverting to manufacturer values

5.2 Operation Control

F200 Source of start command	Setting range: 0: Keypad command; 1: Terminal command; 2: Keypad+Terminal; 3: MODBUS; 4: Keypad+Terminal+MODBUS	Mfr's value: 4
F201 Source of stop command	Setting range: 0: Keypad command; 1: Terminal command; 2: Keypad+Terminal; 3: MODBUS; 4: Keypad+Terminal+MODBUS	Mfr's value: 4

- F200 and F201 are the resource of selecting inverter control commands.
- Inverter control commands include: starting, stopping, forward running, reverse running, jogging, etc.
- “Keypad command” refers to the start/stop commands given by the “Run” or “stop/reset” key on the keypad.
- “Terminal command” refers to the start/stop command given by the “Run” terminal defined by F316-F323.
- When F200=3 and F201=3, the running command is given by MODBUS communication.
- When F200=2 and F201=2, “keypad command” and “terminal command” are valid at the mean time, F200=4 and F201=4 are the like.

F202 Mode of direction setting	Setting range: 0: Forward running locking; 1: Reverse running locking; 2: Terminal setting	Mfr's value: 0
--------------------------------	---	----------------

- The running direction is controlled by this function code together with other speed control mode which can set the running direction of inverter. When auto-circulation speed is selected by F500=2 or F208≠0, this function code is not valid.
- When speed control mode without controlling direction is selected, the running direction of inverter is controlled by this function code, for example, keypad controls speed.

Direction given by F202	Direction given by other control mode	Running direction	remarks
0	0	0	0 means forward. 1 means reverse.
0	1	1	
1	0	1	
1	1	0	

F203 Main frequency source X	Setting range: 0: Memory of digital given; 1: External analog AI1; 2: External analog AI2; 3: Pulse input given; 4: Stage speed control; 5: No memory of digital given; 7, 8:Reserved; 9: PID adjusting; 10: MODBUS	Mfr's value: 0
------------------------------	--	----------------

· Main frequency source is set by this function code.

·0: Memory of digital given

Its initial value is the value of F113. The frequency can be adjusted through the key “up” or “down”, or through the “up”, “down” terminals.

“Memory of digital given” means after inverter stops, the target frequency is the running frequency before stop. If the user would like to save target frequency in memory when the power is disconnected, please set F220=1, i.e. frequency memory after power down is valid.

1: External analog AI1; 2: External analog AI2

The frequency is set by analog input terminal AI1 and AI2. The analog signal may be current signal (0-20mA or 4-20mA) or voltage signal (0-5V or 0-10V), which can be chosen by switch code. Please adjust the switch code according to practical situations, refer to fig 4-4 and table 4-2.

When inverters leave the factory, the analog signal of AI1 channel is DC voltage signal, the range of voltage is 0-10V, and the analog signal of AI2 channel is DC current signal, the range of current is 0-20 mA. If 4-20mA current signal is needed, please set lower limit of analog input F406=2, which input resistor is 500OHM. If some errors exist, please make some adjustments.

3: Pulse input given

When frequency is given by pulse input, the pulse is only inputted by DI1 terminal. The max pulse frequency is 10K. The related parameters are from F440 to F446.

4: Stage speed control

Multi-stage speed control is selected by setting stage speed terminals F316-F322 and function codes of multi-stage speed section. The frequency is set by multi-stage terminal or automatic cycling frequency.

5: No memory of digital given

Its initial value is the value of F113. The frequency can be adjusted through the key “up” or “down”, or through the “up”, “down” terminals.

“No memory of digital given” means that the target frequency will restore to the value of F113 after stop no matter the state of F220.

9: PID adjusting

When PID adjusting is selected, the running frequency of inverter is the value of frequency adjusted by PID. Please refer to instructions of PID parameters for PID given resource, PID given numbers, feedback source, and so on.

10: MODBUS

The main frequency is given by MODBUS communication.

<p>F204 Accessorial frequency source Y</p>	<p>Setting range: 0: Memory of digital given; 1: External analog AI1; 2: External analog AI2; 3: Pulse input given; 4: Stage speed control; 5: PID adjusting;</p>	<p>Mfr's value: 0</p>
--	---	-----------------------

- When accessorial frequency Y is given to channel as independent frequency, it has the same function with main frequency source X.
- When F204=0, the initial value of accessorial frequency is set by F155. When accessorial frequency controls speed independently, polarity setting F156 is not valid.
- When F207=1 or 3, and F204=0, the initial value of accessorial frequency is set by F155, the polarity of accessorial frequency is set by F156, the initial value of accessorial frequency and the polarity of accessorial frequency can be checked by F157 and F158.
- When the accessorial frequency is given by analog input (AI1, AI2), the setting range for the accessorial frequency is set by F205 and F206.
- Note: accessorial frequency source Y and main frequency source X can not use the same frequency given channel.

<p>F205 reference for selecting accessorial frequency source Y range</p>	<p>Setting range: 0: Relative to max frequency; 1: Relative to main frequency X</p>	<p>Mfr's value: 0</p>
<p>F206 Accessorial frequency Y range (%)</p>	<p>Setting range: 0~100</p>	<p>Mfr's value: 100</p>

- When combined speed control is adopted for frequency source, F206 and F205 are used to confirm the relative object of the setting range for the accessorial frequency.
- F205 is to confirm the reference of the accessorial frequency range. If it is relative to main frequency, the range will change according to the change of main frequency X.

<p>F207 Frequency source selecting</p>	<p>Setting range: 0: X; 1: X+Y; 2: X or Y (terminal switchover; X is prior to Y when no switchover); 3: X or X+Y (terminal switchover); 4: Combination of stage speed and analog 5: X-Y 6: X+Y-YMAX*50% 7: Combination of stage speed and digit 1 9: X/Y 10: Max(X,Y) 11: Min(X,Y)</p>	<p>Mfr's value: 0</p>
--	---	-----------------------

- Select the channel of setting the frequency. The frequency is given by combination of main frequency X and accessorial frequency Y.
- When F207=0, the frequency is set by main frequency source.
- When F207=1, X+Y, the frequency is set by adding main frequency source to accessorial frequency source.

X or Y cannot be given by PID.

·When F207=2, main frequency source and accessorial frequency source can be switched over by frequency source switching terminal.

·When F207=3, main frequency given and adding frequency given(X+Y) can be switched over by frequency source switching terminal. X or Y cannot be given by PID.

·When F207=4, stage speed setting of main frequency source has priority over analog setting of accessorial frequency source (only suitable for F203=4 F204=1).

·When F207=5, X-Y, the frequency is set by subtracting accessorial frequency source from main frequency source. If the frequency is set by main frequency or accessorial frequency, PID speed control cannot be selected.

·When F207=6, $X+Y-Y_{MAX} * 50\%$, the frequency is given by both main frequency source and accessorial frequency source. X or Y can be given by PID. When F205=0, $Y_{MAX}=F111 * F206$. When F205=1, $Y_{MAX}=X * F206$.

·When F207=7, the stage speed of main frequency source is in preference to the given digital value of accessorial frequency resource. (Only applied to F203=4, F204=0)

·When F207=9, target frequency is main frequency X divided by the accessorial frequency Y.

·When F207=10, target frequency is the larger of the main frequency X and the accessorial frequency Y.

·When F207=11, target frequency is the smaller of the main frequency X and the accessorial frequency Y.

Note:

1. When F203=4 and F204=1, the difference between F207=1 and F207=4 is that when F207=1, frequency source selecting is the addition of stage speed and analog, when F207=4, frequency source selecting is stage speed with stage speed and analog given at the same time. If stage speed given is canceled and analog given still exists, inverter will run by analog given.
2. Frequency given mode can be switched over by selecting F207. For example: switching PID adjusting and normal speed control, switching stage speed and analog given, switching PID adjusting and analog given, and so on.
3. The acceleration/deceleration time of stage speed is set by function code of corresponding stage speed time. When combined speed control is adopted for frequency source, the acceleration/deceleration time is set by F114 and F115. When the combination of speed control(excluding auto-cycle), accelerate/decelerate by the first acceleration/deceleration time before giving stage-speed signal; accelerate/decelerate by corresponding stage speed time after giving stage-speed signal.
4. The mode of automatic cycle speed control is unable to combine with other modes.
5. When F207=2 (X or Y terminals switchover), if main frequency is not set to be under stage-speed control, accessorial frequency can be set to under automatic cycle speed control (F204=4, F500=2). Through the defined switchover terminal, the control mode (defined by X) and automatic cycle speed control (defined by Y) can be freely switched.
6. If the settings of main frequency and accessorial frequency are the same, only main frequency will be valid.
7. If F207=6, F205=0, and F206=100, $X+Y-Y_{MAX} * 50\% = X+Y-F111 * 50\%$; If F207=6, F205=1, and F206=100, $X+Y-Y_{MAX} * 50\% = X+Y-X * 50\%$.

<p>F208 Terminal two-line/three-line operation control</p>	<p>Setting range: 0: No function 1: Two-line operation mode 1; 2: Two-line operation mode 2; 3: three-line operation mode 1;</p>	<p>Mfr's value: 0</p>
--	--	-----------------------

	4: three-line operation mode 2; 5: start/stop controlled by direction pulse	
--	--	--

- When selecting two-line type or three-line type), F200, F201 and F202 are invalid.
- Five modes are available for terminal operation control.
- “FWD”, “REV” and “X” are three terminals designated in programming DI1~DI8.

1. Two-line operation mode 1: this mode is the most popularly used two-line mode. The running direction of mode is controlled by FWD, REV terminals.

E.g.: “FWD” terminal-----“open”: stop, “closed”: forward running;
 “REV” terminal-----“open”: stop, “closed”: reverse running;
 “CM” terminal-----common port

K1	K2	Running command
0	0	Stop
1	0	Forward running
0	1	Reverse running
1	1	Stop

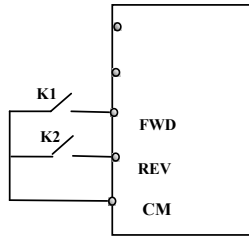

2. Two-line operation mode 2: when this mode is used, FWD is enable terminal, the direction is controlled by REV terminal.

For example: “FWD” terminal-----“open”: stop, “closed”: running;

“REV” terminal-----“open”: forward running, “closed”: reverse running;
 “CM” terminal-----common port

K1	K2	Running command
0	0	Stop
0	1	Stop
1	0	Forward running
1	1	Reverse running

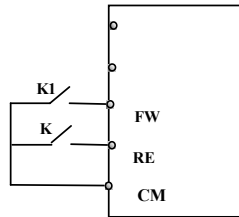

3. Three-line operation mode 1:

In this mode, X terminal is enable terminal, the direction is controlled by FWD terminal and REV terminal. Pulse signal is valid.

Stopping commands is enabled by opening X terminal.

SB3: Stop button

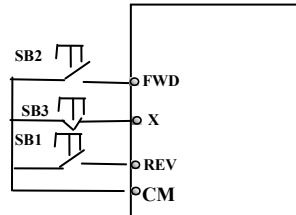

SB2: Forward button.

SB1: Reverse button.

4. Three-line operation mode 2:

In this mode, X terminal is enable terminal, running command is controlled by FWD terminal. The running direction is controlled by REV terminal, and stopping command enable by opening X terminal.

SB1: Running button

SB2: Stop button

K1: direction switch. Open stands for forward running; close stands for reverse running.

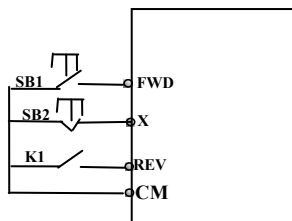

5. Start/stop controlled by direction pulse:

“FWD” terminal—(impulse signal: forward/stop)

“REV” terminal—(impulse signal: reverse/stop)

“CM” terminal—common port

Note: when pulse of SB1 triggers, inverter will run forward. When the pulse triggers again, inverter will stop running.

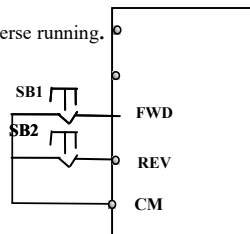

F209	Selecting the mode of stopping the motor	Setting range: 0: stop by deceleration time; 1: free stop 2: DC braking stop	Mfr's value: 0
------	--	---	----------------

When the stop signal is input, stopping mode is set by this function code:

F209=0: stop by deceleration time

Inverter will decrease output frequency according to setting acceleration/deceleration curve and decelerating time, after frequency decreases to 0, inverter will stop. This is often common stopping type. During the process of speed track, this function is invalid. And inverter will be forced to stop during this process.

F209=1: free stop

After stop command is valid, inverter will stop output. Motor will free stop by mechanical inertia.

F209=2: Set DC braking waiting time (F656), DC braking frequency (F603) and braking duration time (F605) of shut-down status reasonably when using this function,

F210	Frequency display accuracy(Hz)	Setting range: 0.01~2.00	Mfr's value: 0.01
------	--------------------------------	--------------------------	-------------------

Under keypad speed control or terminal UP/DOWN speed control, frequency display accuracy is set by this function code and the range is from 0.01 to 2.00. For example, when F210=0.5, UP/DOWN terminal is pressed at one time, frequency will increase or decrease by 0.5Hz.

This function is valid when inverter is in the running state. When inverter is in the standby state, no matter what value of this function code is, frequency will increase or decrease by 0.01Hz.

F211	Speed of digital control (Hz/S)	Setting range: 0.01~100.0	Mfr's value: 5.00
------	---------------------------------	---------------------------	-------------------

When UP/DOWN terminal is pressed, frequency will change at the setting rate. The Mfr's value is 5.00Hz/s.

In practical application, set the value of F211 refer to the calculation of $F114=50.00(\text{Hz})/F114$ if request to keep consistent with reset frequency and actual running frequency by setting UP/DOWN terminals. For example, $F114=5.0\text{s}$, $F211=50.00(\text{Hz})/5.0(\text{s})=10(\text{Hz/S})$

F212 Direction memory	Setting range: 0: Invalid 1: Valid	Mfr's value: 0
<p>· This function is valid when three-line operation mode 1(F208=3) is valid.</p> <p>· When F212=0, after inverter is stopped, reset and repower on, the running direction is not memorized.</p> <p>· When F212=1, after inverter is stopped, reset and repower on, if inverter starts running but no direction signal, inverter will run according the memory direction.</p>		
F213 Auto-starting after repowered on	Setting range: 0: invalid; 1: valid 2: according to last running mode	Mfr's value: 0
F214 Auto-starting after reset	Setting range: 0: invalid; 1: valid	Mfr's value: 0
<p>· Whether or not to start automatically after repowered on is set by F213</p> <p>F213=0, after repower-on, inverter will not run automatically unless running command is given to inverter.</p> <p>F213=1, auto-starting after repowered on is valid. When inverter is power off and then powered on again, it will run automatically after the time set by F215. If F220=0 frequency memory after power-down is not valid, inverter will run by the setting value of F113.</p> <p>F213=2, auto-starting after repowered on is valid. When inverter is power off and then powered on again, it will run automatically according to the running mode before power-down. If F220=0 frequency memory after power-down is not valid, inverter will run by the setting value of F113.</p> <p>· Whether or not to start automatically after fault resetting is set by F214</p> <p>When F214=1, if fault occurs, inverter will reset automatically after delay time for fault reset (F217). After resetting, inverter will run automatically after the auto-starting delay time (F215).</p> <p>If frequency memory after power-down (F220) is valid, inverter will run at the speed before power-down. Otherwise, inverter will run at the speed set by F113.</p> <p>In case of fault under running status, inverter will reset automatically and auto-start. In case of fault under stopped status, the inverter will only reset automatically.</p> <p>When F214=0, after fault occurs, inverter will display fault code, it must be reset by manually.</p>		
F215 Auto-starting delay time	Setting range: 0.1~3000.0	Mfr's value: 60.0
F215 is the auto-starting delay time for F213 and F214. The range is from 0.1s to 3000.0s.		
F216 Times of auto-starting in case of repeated faults	Setting range: 0~5	Mfr's value: 0
F217 Delay time for fault reset	Setting range: 0.0~3000.0	Mfr's value: 3.0
F219 EEPROM write operation	Setting range: 0:enabled to write 1:prohibit writing	Mfr's value: 1
<p>F216 sets the most times of auto-starting in case of repeated faults. If starting times are more than the setting value of this function code, inverter will not reset or start automatically after fault. Inverter will run after running command is given to inverter manually.</p> <p>F217 sets delay time for fault reset. The range is from 0.0 to 10.0S which is time interval from fault to resetting.</p> <p>When F219=1 (address 2001H is not operated by PC/PLC), the function code is modified by communication, and it is not saved in the EEPROM. It means there is no memory when power down. When F219=0 ((address 2001H is not operated by PC/PLC), the function code is modified by communication, and it is saved in the EEPROM. It means there is memory when power down.</p> <p>When F160=1, the value of F219 cannot be reverted to Mfr's value.</p>		
F220 Frequency memory after power-down	Setting range: 0: invalid; 1: valid	Mfr's value: 0

F220 sets whether frequency memory is valid or not after power-down.

This function is valid for F213 and F214. Whether or not to memory running state after power-down or malfunction is set by this function.

The function of frequency memory after power-down is valid for main frequency and accessorial frequency that is given by digital. Because the digital given accessorial frequency has positive polarity and negative polarity, it is saved in the function codes F155 and F156.

F221	X+Y-50%(%)	Setting range: 0~200	Mfr's value: 50
F222	count memory selection	Setting range: 0: Invalid 1: Valid	Mfr's value: 0

F222 sets whether or not count memory is valid. Whether or not to memory counting values after power-down or malfunction is set by this function.

F223	Main frequency coefficient	Setting range: 0.0~100.0	Mfr's value: 100.0
------	----------------------------	--------------------------	--------------------

Target frequency=main frequency*main frequency coefficient.

F224	when target frequency is lower than Min frequency	Setting range: 0: stop 1: run at min frequency	Mfr's value: 0
------	---	--	----------------

F224=0, when target frequency is lower than MIN (F112, 0.1), inverter will stop.

F224=1, when target frequency is lower than Min frequency, inverter will run at Min frequency.

Table 6-1 Combination of Speed Control

F203 \ F204	0. Memory of digital setting	1 External analog AI1	2 External analog AI2	3 Pulse input given	4 Terminal stage speed control	5 PID adjusting
0 Memory of Digital setting	○	●	●	●	●	●
1 External analog AI1	●	○	●	●	●	●
2 External analog AI2	●	●	○	●	●	●
3 Pulse input given	●	●	●	○	●	●
4 Terminal Stage speed control	●	●	●	●	○	●
5 Digital setting	○	●	●	●	●	●
9 PID adjusting	●	●	●	●	●	○
10 MODBUS	●	●	●	●	●	●

●: Inter-combination is allowable.

○: Combination is not allowable.

The mode of automatic cycle speed control is unable to combine with other modes. If the combination includes the mode of automatic cycle speed control, only main speed control mode will be valid.

F226	Validity of Skip Frequency	0: Invalid during accelerating/deceleration 1: Invalid during deceleration 2: Always valid	Mfr's value: 0
------	----------------------------	--	----------------

When F226=0, Skipping frequency is only valid during stable running.

When F226=1, Skipping frequency is only valid during accelerating and stable running.

When F226=2, it is always valid at accelerating, decelerating and stable running.

Please refer to the relative parameter of F127-F130.

Note: During accelerating and decelerating, the skip width can not be wide.

F233 Time Unit of Accel/decel	Setting range: 0: 0.1s 1: 0.01s	Mfr's value: 0
-------------------------------	------------------------------------	----------------

When F233=0, the time unit of F114-F117 and stage-speed control is 0.1s.

When F233=1, the time unit of F114-F117 and stage-speed control is 0.01s.

F234 Switchover Frequency During Deceleration process (Hz)	Setting range: 0.00: Invalid 0.00~F111	Mfr's value: 0.00
--	---	-------------------

· When F234=0, this function is not valid.

When F234≠0, during deceleration process, if the running frequency is higher than F234, the decelerating time is not changed. If the running frequency is lower than F234, the inverter will run at the second deceleration time(F117).

Note: In the mode of washing machine, this function is valid in stage-speed control. During deceleration process, if the running frequency is higher than F234, the inverter will run at the second deceleration time(F117).

F277 Third acceleration time(S)	Setting range: 0.1~3000	Subject to inverter model
F278 Third deceleration time(S)		
F279 Fourth acceleration time(S)		
F280 Fourth deceleration time(S)		

5.3 Multifunctional Input and Output Terminals

5.3.1 Digital multifunctional output terminals

F300 Relay 1 token output	Setting range: 0~59 Refer to table 5-2 for detailed instructions.	Mfr's value: 1
F301 DO1 token output		Mfr's value: 14
F302 Relay 2 token output		Mfr's value: 5

F300~F302 are still valid when rotate speed tracking.

In water supply system, if the fixed mode or timing interchanging mode is selected, relay token output and DO1 token output is invalid.

Table 5-2 Instructions for digital multifunctional output terminal

Value	Function	Instructions
0	no function	Output terminal has no functions.
1	inverter fault protection	When inverter has fault, ON signal is output. When inverter is in SLP\SSLP\PCE, no signal is output.
2	over latent frequency 1	Please refer to instructions from F307 to F309.
3	over latent frequency 2	Please refer to instructions from F307 to F309.

4	free stop	Under free stop status, after stop command is given, ON signal is output until inverter completely stops.
5	In running status 1	Indicating that inverter is running and ON signal is output.
6	DC brake	Indicating that the drive is in DC braking mode.
7	acceleration/deceleration time switchover	Indicating that inverter is in the status of acceleration/deceleration time switchover
8	Reaching the Set Count Value	This terminal will be "action" when inverter carries the external count instruction and count value reaches the set value of F314.
9	Reaching the Designated Count Value	This terminal will be "action" when inverter carries the external count instruction and count value reaches the set value of F315.
10	Inverter overload pre-alarm	After inverter overloads, ON signal is output after the half time of protection timed, ON signal stops outputting after overload stops or overload protection occurs.
11	motor overload pre-alarm	After motor overloads, ON signal is output after the half time of protection timed, ON signal stops outputting after overload stops or overload protection occurs.
12	stalling	During accel/decel process, inverter stops accelerating/decelerating because inverter is stalling, and ON signal is output.
13	Inverter is ready to run	When inverter is powered on. Protection function is not in action and inverter is ready to run, then ON signal is output.
14	In running status 2	Indicating that inverter is running and ON signal is output. When inverter is running at 0HZ, it seems as the running status, and ON signal is output.
15	frequency arrival output	Indicating inverter runs to the setting target frequency, and ON signal is output. See F312.
16	overheat pre-alarm	When testing temperature reaches 80% of setting value, ON signal is output. When overheat protection occurs or testing value is lower than 80%of setting value, ON signal stops outputting.
17	Over latent current output	When output current of inverter reaches the setting overlatent current, ON signal is output. See F310 and F311.
18	Analog line disconnection protection	Indicating inverter detects analog input lines disconnection, and ON signal is output. Please refer to F741.
19	Under-load 1 pre-alarm	Please refer to FA26 and FA27.
20	Zero current detecting output	When inverter output current has fallen to zero current detecting value and after the setting time of F755, ON signal is output. Please refer to F754 and F755.
21	Write DO1by PC/PLC	1 means token output is valid. 0 means token output is invalid.
22	Write TA2/TC2 by PC/PLC	
23	Write TA1/TC1 by PC/PLC	
24	Watchdog output token	The token output is valid when inverter trips into Err6.
25-27	Reserved	
28	SLP	When sleep mode is active, ON signal is output. Note: it is not a faulty, so no signal is output on fault relay.
30	General pump is running	Indicating some general pumps are running.

31	Converter pump is running	Indicating some converter pumps are running.
32	Over-limit pressure token	Indicating the max limit value when PID adjusting is valid and negative feedback is selected, and feedback pressure is higher than max pressure set by F503
41	Frequency source switchover	Indicating the function of frequency source switchover.
43	Communication timeout 1	When F907>0, and receiving the previous data, if after the time set by F907, the next data is not received, inverter will output communication timeout signal. The timeout signal will be cleared by this terminal, and after receiving correct data, inverter will accumulate time again.
45	Lower than setting token temperature	Output token is valid when temperature is not higher than 0℃ ; Output token is invalid when temperature is higher than 0℃+2℃;
56	Irradiation pre-alarm	This token signal is valid when before irradiation is lower than FB56. This token signal is invalid when before illumination is higher than FB56.
57	Battery panel bypass	When before illumination is lower than FB57, bus voltage is near to rated value, the token signal is valid after 15s. When before illumination is higher than FB56, the token signal is invalid.
59	oPEn	When drive trips into oPEn, the terminal is valid.

F303 DO output mode selection	Setting range: 0: Switch level output 1 : pulse output	Mfr's value: 0
-------------------------------	--	----------------

- When switch level output is selected, all terminal functions in table 5-2 can be defined by F301.
- When pulse output is selected, DO1 can be defined as high-speed pulse output terminal. The max pulse frequency is 100 KHz. The related function codes are F449、F450、F451、F452、F453.

F304 S curve beginning stage proportion (%)	Setting range: 2.0~50.0	30.0
F305 S curve ending stage proportion (%)	Setting range: 2.0~50.0	30.0
F306 Acceleration/deceleration mode	Setting range: 0: Straight-line 1: S curve	0

The setting value of F304, F305 is the percentage of this time count for the time from current frequency to target frequency.

Please refer to Fig 5-9 about S curve acceleration/deceleration:

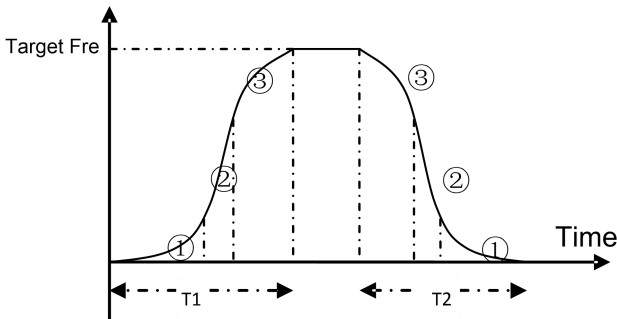

Fig 5-9 S Curve Acceleration /Deceleration

T1 is the acceleration time from present frequency to target frequency.

T2 is the deceleration time from present frequency to target frequency.

During the acceleration process, in the ① stage, the acceleration slope is bigger gradually, in the ② stage, the acceleration slope is constant, in the ③ stage, the acceleration slope is weaker gradually.

F307	Characteristic frequency 1(Hz)	Setting range: F112~F111	Mfr's value: 10
F308	Characteristic frequency 2(Hz)		Mfr's value: 50
F309	Characteristic frequency width (%)	Setting range: 0~100	Mfr's value: 50

When F300=2, 3, F301=2, 3 and F302=2, 3 and token characteristic frequency is selected, this group function codes set characteristic frequency and its width. For example: setting F301=2, F307=10, F309=10, when frequency is higher than F307, DO1 outputs ON signal. When frequency is lower than (10-10*10%) =9Hz, DO1 outputs OFF signal.

F310	Characteristic current (A)	Setting range: 0~5000.0	Mfr's value: Rated current
F311	Characteristic current width(%)	Setting range: 0~100	Mfr's value: 10

When F300=17 and F301=17 and token characteristic current is selected, this group function codes set characteristic current and its width.

For example: setting F301=17, F310=100, F311=10, when inverter current is higher than F310, DO1 outputs ON signal. When inverter current is lower than (100-100*10%) =90A, DO1 outputs OFF signal.

F312	Frequency arrival threshold	Setting range: 0.00~5.00	Mfr's value: 0.00
------	-----------------------------	--------------------------	-------------------

When F300=15 and F301=15, threshold range is set by F312.

For example: when F301=15, target frequency is 20HZ and F312=2, the running frequency reaches 18HZ (20-2), ON signal is output by DO1 until the running frequency reaches target frequency.

F313	Count frequency divisions	Setting range: 1~65000	Mfr's value: 1
F314	Set count value	Setting range: F315~65000	Mfr's value: 1000
F315	Designated count value	Setting range: 1~F314	Mfr's value : 500

- Count frequency divisions refer to the ratio of actual pulse input and inverter's count times, i.e.,

$$\text{Inverter's Count Times} = \frac{\text{Actual Pulse Input}}{\text{Count Frequency Division}}$$

E.g.: When F313=3, inverter will count once for every 3 inputs of external pulse.

- Set count values refer to a count width pulse output by the output terminal (DO1 terminal or relay) programmed with "reaching the set count values" function when a certain number of pulses are input from DI1. Count will restart after the count value reaches "set times".

As shown in Fig 5-6: if F313=1, F314=8, F301=8, DO1 will output an instruction signal when DI1 inputs the 8th pulse.

- Designated count values refer to a pulse output by the output terminal (DO1 or RELAY terminal) programmed with "reaching the set count values" function when a certain number of pulses are input from DI1, until count value reaches the "set times".

As shown in Fig 5-10: if F313=1, F314=8, F315=5, F300=9, relay will output an instruction signal when DI1 inputs the 5th pulse, relay will output an instruction signal until reaching "set count times 8".

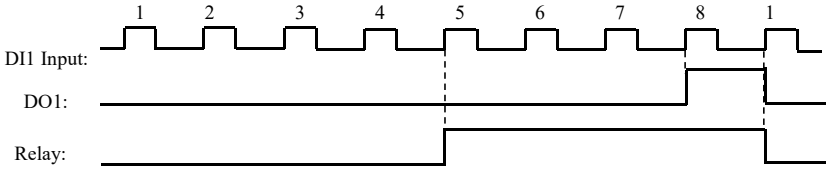

Fig 5-10 Set Count times & Designated Count Times

5.3.2 Digital multifunctional input terminals

F316	DI1 terminal function setting	Setting range: 0: No function; 1: Running ; 2: Halt; 3: Multi-stage speed 1; 4: Multi-stage speed 2; 5: Multi-stage speed 3; 6: Multi-stage speed 4; 7: Reset;	Mfr's value: 11
F317	DI2 terminal function setting	8: Free stop; 9: External emergency stop; 10: Acceleration/deceleration forbidden terminal; 11: Forward run jogging;	Mfr's value: 9
F318	DI3 terminal function setting	12: Reverse run jogging; 13: UP frequency increasing; 14: DOWN frequency decreasing; 15: "FWD"; 16: "REV"; 17: Three-line type input "X" ;	Mfr's value: 15
F319	DI4 terminal function setting	18: Acceleration/deceleration time switchover 1; 19: Reserved; 20: switchover between speed and torque; 21: frequency source switchover	Mfr's value: 16
F320	DI5 terminal function setting	22: Count input; 23: Count reset 30: Water shortage signal 31: Water signal 32: Fire pressure switchover; 33: Emergency fire control 34: Acceleration / deceleration switchover 2 35: Pulse start 36: Pulse stop	Mfr's value: 7

F321 DI6 terminal function setting	37: Common-open PTC heat protection 38: Common-close PTC heat protection 42: oPEn protection terminal. 44: Pressure selection 1 45: Pressure selection 2 46: Manual pressure selection 47: Auto pressure selection 49: PID pause 51: Motor switchover 53: Watchdog 54: Frequency reset 60: Communication timeout 2 signal elimination 61: Start/stop terminals 71: Water injection 72: Water pump 73: High water level 74: Low water level 75: Pump cleaning 76: Quit fire mode after manual stop 77: Anti-rust and anti-freeze enabled 78: Pressure rising 79: Pressure dropping 80: Pump filling	Mfr's value: 8
------------------------------------	--	----------------

- This parameter is used for setting corresponding function for multifunctional digital input terminal.
- Both free stop and external emergency stop of the terminal have the highest priority.
- When pulse given is selected, DI1 terminal is set as pulse signal input terminal automatically.
- DI1 terminal function is set as input port of pulse signal when selecting pulse frequency speed adjustment.

Table 5-3 Instructions for digital multifunctional input terminal

Value	Function	Instructions
0	No function	Even if signal is input, inverter will not work. This function can be set by undefined terminal to prevent mistake action.
1	Running terminal	When running command is given by terminal or terminals combination and this terminal is valid, inverter will run. This terminal has the same function with "RUN" key in keypad.
2	Stop terminal	When stop command is given by terminal or terminals combination and this terminal is valid, inverter will stop. This terminal has the same function with "stop/reset" key in keypad.
3	Multistage speed terminal 1	15-stage speed is realized by combination of this group of terminals. See table 5-5.
4	Multistage speed terminal 2	
5	Multistage speed terminal 3	
6	Multistage speed terminal 4	
7	Reset terminal	
8	Free stop terminal	Inverter closes off output and motor stop process is not controlled by inverter. This mode is often used when load has big inertia or there are no requirements for stop time. This mode has the same function with free stop of F209.
9	External emergency stop terminal	When external malfunction signal is given to inverter, malfunction will occur and inverter will stop.

10	Acceleration/deceleration forbidden terminal	Inverter will not be controlled by external signal (except for stop command), and it will run at the current output frequency.
11	forward run jogging	Forward jogging running and reverse jogging running. Refer to F124, F125 and F126 for jogging running frequency, jogging acceleration/deceleration time.
12	reverse run jogging	
13	UP frequency increasing terminal	When frequency source is set by digital given, the setting frequency can be adjusted which rate is set by F211.
14	DOWN frequency decreasing terminal	
15	“FWD” terminal	When start/stop command is given by terminal or terminals combination, running direction of inverter is controlled by external terminals.
16	“REV” terminal	
17	Three-line input “X” terminal	“FWD”、 “REV”、 “CM” terminals realize three-line control. See F208 for details.
18	acceleration/deceleration time switchover	Switch to the second acceleration/deceleration time if this function is valid. See details in F116, F117.
19	Reserved	Reserved
20	Rotate speed/torque switchover	Switchover between rotate speed and torque.
21	frequency source switchover terminal	When F207=2, main frequency source and accessorial frequency source can be switched over by frequency source switching terminal. When F207=3, X and (X + Y) can be switched over by frequency source switching terminal.
22	Count input terminal	Built-in count pulse input terminal.
23	Count reset terminal	Reset terminal count value to zero.
30	Water shortage signal	When PID control, FA26=1, corresponding terminal has signal, inverter will enter protection state.
31	Water signal	When PID control, FA26=1, corresponding terminal has signal, the inverter will relieve water shortage protection state
32	Fire pressure switchover	When PID control is valid and this terminal is valid, the setting value of PID switches into fire pressure given (FA58).
33	Emergency fire control	When emergency fire mode (FA59) is valid, inverter will be in emergency fire mode.
34	Acceleration / deceleration switchover 2	Please refer to Table 5-4.
35	Pulse start	When F200 selects terminal start and DI selects pulse start, a valid pulse can be detected to start normally.
36	Pulse stop	When F201 selects terminal stop and DI selects pulse stop, a valid pulse can be detected to stop normally
37	Common-open PTC heat protection	When this function is valid, common-open heat relay is externally connected. When common-open contact is closed and inverter is in the running status, inverter will trip into OHI.
38	Common-close PTC heat protection	When this function is valid, common-close heat relay is externally connected. When common-close contact is open and inverter is in the running status, inverter will trip into OHI.
42	oPEn protection	When there is no signal input on oPEn terminal, oPEn protection is enable and the keypad displays oPEn alarm. When the signal input is recovered, oPEn will disappear automatically.

43	Decelerate to stop when power failure	When F657=3, if this terminal is valid, inverter will decelerate to stop at instantaneous power failure.
44	Pressure selection 1	Please refer to table 6-4 PID outlet target pressure selection
45	Pressure selection 2	
46	Manual pressure selection	
47	Auto pressure selection	When the automatic operation signal is valid, the system automatically starts running.
49	PID paused	PID adjustment is invalid temporarily.
53	Watchdog	During the time set by F326 elapses without an impulse being registered, inverter will trip into Err6, and inverter will stop according to stop mode set by F327.
54	Frequency reset	Current target frequency changes to setting value of F113 if frequency terminal is valid in application 4.
60	Communication timeout 2	When F907>0, and receiving the previous data, if after the time set by F907, the next data is not received, inverter will output communication timeout signal. The timeout signal will be cleared by this terminal, and after receiving correct data, inverter will accumulate time again.
61	Start-stop terminal	When the function is invalid, it is stop terminal. When the function is valid, it is start terminal.
71	Water injection	When FA96=1, when water injection signal is valid, if high water level signal is valid, inverter will stop. When water pump signal is valid, if low water level signal is valid, inverter will stop.
72	Water pump	
73	High water level	
74	Low water level	
75	Pump cleaning	When pump cleaning signal is valid, pump cleaning function will be carried on.
76	Quit fire mode after manual stop	Fire mode will quit when manual stop signal is valid.
77	Anti-rust and anti-freeze enabled	When this function is valid, dormant master will be waked up after FB41. After master runs by FB42, if master will enter dormancy status again. After slave stops for FB41, it will run immediately. After slave runs for FB42, it will stop. Running frequency is dormancy frequency. Note: general pump does not have anti-freeze function.

78	Pressure rising	When pressure rising signal is valid, each pulse will make target pressure rise by one unit.
79	Pressure dropping	When pressure dropping signal is valid, each pulse will make target pressure drop by one unit.
80	Pump filling	Pump filling function will be valid.

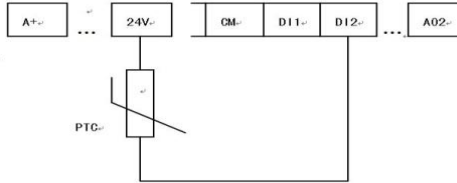

Fig 5-11 PTC protection sketch map

User can follow the followings operations if using PTC as thermal protection. When the coding switch is in the “NPN” side and terminal is set as 38, PTC resistor should be connected between CM and Dlx terminal. When the coding switch is in “PNP” side, PTC resistor should be connected between Dlx and 24V. The recommended resistor value is 16.5K.

Because the precision of external PTC has some differences with optocoupler consistency, protection value precision will be bad; thermal protection relay is suggested to be used.

Table 5-4 PID outlet target pressure selection

32: fire pressure switchover	46: manual pressure selection	45: pressure selection 2	44: pressure selection 1	Target pressure
√	*	*	*	FA58
×	√	*	*	FB11
×	×	×	×	FA04
×	×	×	√	FA86
×	×	√	×	FA87
×	×	√	√	FA88

Note: √ means terminal valid. × means terminal invalid. * means terminal free status.

Table 5-5 Acceleration/deceleration selection

Accel/decel switchover 2 (34)	Accel/decel switchover 1 (18)	Present accel/decel time	Related parameters
0	0	The first accel/decel time	F114, F115
0	1	The second accel/decel time	F116, F117
1	0	The third accel/decel time	F277, F278
1	1	The fourth accel/decel time	F279, F280

Table 5-6 Instructions for multistage speed

K4	K3	K2	K1	Frequency setting	Parameters
0	0	0	0	None	None
0	0	0	1	Multi-stage speed 1	F504/F519/F534/F549/F557/F565
0	0	1	0	Multi-stage speed 2	F505/F520/F535/F550/F558/F566
0	0	1	1	Multi-stage speed 3	F506/F521/F536/F551/F559/F567
0	1	0	0	Multi-stage speed 4	F507/F522/F537/F552/F560/F568
0	1	0	1	Multi-stage speed 5	F508/F523/F538/F553/F561/F569
0	1	1	0	Multi-stage speed 6	F509/F524/F539/F554/F562/F570
0	1	1	1	Multi-stage speed 7	F510/F525/F540/F555/F563/F571
1	0	0	0	Multi-stage speed 8	F511/F526/F541/F556/F564/F572
1	0	0	1	Multi-stage speed 9	F512/F527/F542/F573
1	0	1	0	Multi-stage speed 10	F513/F528/F543/F574
1	0	1	1	Multi-stage speed 11	F514/F529/F544/F575
1	1	0	0	Multi-stage speed 12	F515/F530/F545/F576
1	1	0	1	Multi-stage speed 13	F516/F531/F546/F577
1	1	1	0	Multi-stage speed 14	F517/F532/F547/F578
1	1	1	1	Multi-stage speed 15	F518/F533/F548/F579

Note:

- K4 is multi-stage speed terminal 4, K3 is multi-stage speed terminal 3, K2 is multi-stage speed terminal 2, K1 is multi-stage speed terminal 1. And 0 stands for OFF, 1 stands for ON.**
- 0=OFF, 1=ON**
- The setting of this table is valid when F580=0.**

F324 Free stop terminal logic	Setting range: 0: positive logic; 1: negative logic;	Mfr's value: 0
F325 External emergency stop terminal logic		Mfr's value: 0

When multi-stage speed terminal is set to free stop terminal (8) and external emergency stop terminal (9), terminal logic level is set by this group of function codes.

When F324=0 and F325=0, positive logic; NPN mode: terminal input is valid when the input is low level; PNP mode: terminal input is valid when input is high level. Same as active level of other terminals.

When F324=1 and F325=1, negative logic; NPN mode: terminal input is valid when the input is high level; PNP mode: terminal input is valid when input is low level. Opposite with active level of other terminals.

F326 Watchdog time	Setting range: 0.0: Invalid; 0.1~3000.0	Mfr's value: 10.0
F327 Stop mode	Setting range: 0: Free to stop; 1: Deceleration to stop	Mfr's value : 0
F328 Terminal filtering times	Setting range: 1~100	Mfr's value: 20

When F326=0.0, watchdog function is invalid.

When F327=0, and during the time set by F326 elapses without an impulse being registered, inverter will free to stop and it will trip into Err6, and digital output token is valid.

When F327=1, and during the time set by F326 elapses without an impulse being registered, inverter will deceleration to stop, then inverter will trip into Err6, and digital output token is valid.

F329 Run command of start terminal	Setting range: 0: Valid 1: Invalid	Mfr's value: 0
------------------------------------	------------------------------------	----------------

When F329=0, after power on, if start terminals (running terminal, forward jogging, reverse jogging, FWD, REV, 3-line X input enable) is valid, inverter will start running directly.

When F329=1, after power on, if start terminals (running terminal, forward jogging, reverse jogging, FWD, REV, 3-line X input enable) is valid, inverter will start running after disconnect start terminal first and enable it again.

F330 Status display of digital input terminals	Read only
--	-----------

F330 is used to display the status of digital input terminals(DIX).

Please refer to Fig 5-12 about the indicators of DIX digital input terminals, the solid-line box and dotted-line box indicate the invalid and valid respectively.

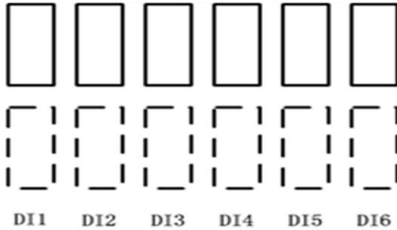
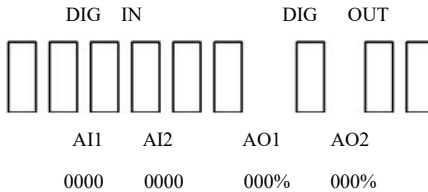

Fig 5-12 Status of digital input terminal

Set F645=22, press “SET”, switch interface by “FUN” key to display 6 boxes. Shorting to DI1~DI6, terminals are valid if number turns from 0 to 1, and six dotted-line boxes are displayed; Terminals are invalid if number does not turn to 1, and six solid-line boxes are displayed.

If user wants to see the detailed status for each terminal, set the function code as F330, press “SET” to enter diagnosis interface, which is showed below.



The first line indicates digital input, digital output; First six boxes in the second line indicate the state of DI terminals, terminals from left to right are DI1~DI6, solid-line box is the state showed as above when terminal is invalid; Black box is displayed when terminal is valid. E.g. If all 6 terminals are valid, will be displayed.

The last three boxes represent the terminal output status of DO1, relay 1 and relay 2, which display mode is the same as DI terminals. E.g. If 3 terminals are valid at same time, will be displayed.

The third line indicates the name of A11, A12 and AO1, AO2. The value displayed in fourth line correspond to the content of third line.

E.g. A11 A12 AO1 AO2
2010 0000 000% 000%

It means the value of A11 is 2010, so are the rest three values.

After checking diagnosis interface, if user needs to exit interface, press “FUN” key to enter first-level menu.

F331Monitoring A11		Read only
F332 Monitoring A12		Read only

Relay/Digital output simulation

F335	Relay output simulation	Setting range: 0: Output inactive. 1: Output active.	Mfr's value: 0
F336	DO1 output simulation		Mfr's value: 0
F337	Relay 2 output simulation		Mfr's value: 0

Take an example of DO1 output simulation, when inverter is in the stop status and enter F336, press the UP key, the DO1 terminal is valid. Loosen the UP key, DO1 remains valid status. After quitting F336, DO1 will revert to initial output status.

Analog output simulation

F338	AO1 output simulation	Setting range: 0~4095	Mfr's value: 0
F339	AO2 output simulation	Setting range: 0~4095	Mfr's value: 0

When inverter is in the stop status, and enter F338 or F339, press the UP key, the output analog will increase, and when press the DOWN key, the output analog will decrease. If loosen the key, analog output remains stable. After quitting the parameters, AO1 and AO2 will revert to initial output status.

F340 Selection of terminal negative logic	Setting range: 0: Invalid 1: DI1 negative logic 2: DI2 negative logic 4: DI3 negative logic 8: DI4 negative logic 16: DI5 negative logic 32: DI6 negative logic	Mfr's value: 0
---	--	----------------

F340 is used for setting the logic of DI terminals.

E.g. If setting DI1 as negative logic, F340=1;

If setting DI2 as negative logic, F340=2;

If user wants to set both DI1 and DI4 to negative logic, please set F340=1+8=9 and the like.

F343	Delay time of DI1 ON	Setting range: 0.00~650.00	Mfr's value: 0.00
F344	Delay time of DI2 ON	Setting range: 0.00~650.00	Mfr's value: 0.00
F345	Delay time of DI3 ON	Setting range: 0.00~650.00	Mfr's value: 0.00
F346	Delay time of DI4 ON	Setting range: 0.00~650.00	Mfr's value: 0.00
F347	Delay time of DI5 ON	Setting range: 0.00~650.00	Mfr's value: 0.00
F348	Delay time of DI6 ON	Setting range: 0.00~650.00	Mfr's value: 0.00
F351	Delay time of DI1 OFF	Setting range: 0.00~650.00	Mfr's value: 0.00
F352	Delay time of DI2 OFF	Setting range: 0.00~650.00	Mfr's value: 0.00
F353	Delay time of DI3 OFF	Setting range: 0.00~650.00	Mfr's value: 0.00
F354	Delay time of DI4 OFF	Setting range: 0.00~650.00	Mfr's value: 0.00
F355	Delay time of DI5 OFF	Setting range: 0.00~650.00	Mfr's value: 0.00
F356	Delay time of DI6 OFF	Setting range: 0.00~650.00	Mfr's value: 0.00

F359	Stop Command Priority	Setting range: 0: Invalid 1: Valid	Mfr's value: 0
------	-----------------------	------------------------------------	----------------

·When F359=1, if inverter get stop command when run command is valid, inverter will stop first.
Inverter will start again only after disconnecting the start terminal first and connect it again.

F360	DO Terminal Negative Logic	Setting range: 0: Invalid 1: DO1 negative logic 2: Relay 2 negative logic 4: Relay 1 negative logic	Mfr's value: 0
------	----------------------------	--	----------------

·If DO1 is negative logic, F360=1. If relay 2 is negative logic, F360=2. If relay 1 is negative logic, F360=4.
If DO1 and relay 2 are negative logic, then F360=1+2=3..

5.4 Analog Input and Output

EM30 series inverters have 2 analog input channels and 2 analog output channels.

F400	Lower limit of AI1 channel input (V)	Setting range: 0.00~F402	Mfr's value: 0.04
F401	Corresponding setting for lower limit of AI1 input	Setting range: 0~2.0	Mfr's value: 1.00
F402	Upper limit of AI1 channel input (V)	Setting range: F400~10.00	Mfr's value: 10.00
F403	Corresponding setting for upper limit of AI1 input	Setting range: 0.00~2.00	Mfr's value: 2.00
F404	AI1 channel proportional gain K1	Setting range: 0.0~10.0	Mfr's value: 1.0
F405	AI1 filtering time constant (S)	Setting range: 0.10~10.0	Mfr's value: 0.10

· In the mode of analog speed control, sometimes it requires adjusting coincidence relation among upper limit and lower limit of input analog, analog changes and output frequency, to achieve a satisfactory speed control effect.

· Upper and lower limit of analog input are set by F400 and F402.

For example: when F400=1, F402=8, if analog input voltage is lower than 1V, system judges it as 0. If input voltage is higher than 8V, system judges it as 10V (Suppose analog channel selects 0-10V). If Max frequency F111 is set to 50Hz, the output frequency corresponding to 1-8V is 0-50Hz.

· The filtering time constant is set by F405.

The greater the filtering time constant is, the more stable for the analog testing. However, the precision may decrease to a certain extent. It may require appropriate adjustment according to actual application.

· Channel proportional gain is set by F404.

If 1V corresponds to 10Hz and F404=2, then 1V will correspond to 20Hz.

· Corresponding setting for upper / lower limit of analog input are set by F401 and F403.

If Max frequency F111 is 50Hz, analog input voltage 0-10V can correspond to output frequency from -50Hz to 50Hz by setting this group function codes. Please set F401=0 and F403=2, then 0V corresponds to -50Hz, 5V corresponds to 0Hz and 10V corresponds to 50Hz. The unit of corresponding setting for upper / lower limit of input is in percentage (%). If the value is greater than 1.00, it is positive; if the value is less than 1.00, it is negative. (e.g. F401=0.5 represents -50%).

If the running direction is set to forward running by F202, then 0-5V corresponding to the minus frequency will cause reverse running, or vice versa.

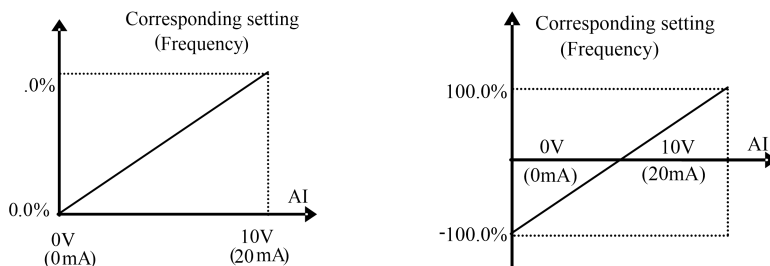
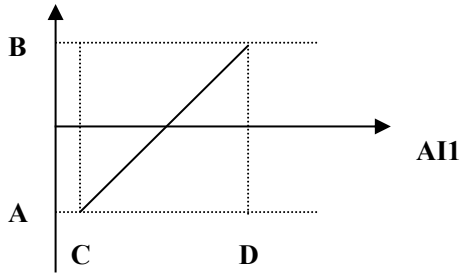

Fig 5-13 correspondence of analog input to setting

The unit of corresponding setting for upper / lower limit of input is in percentage (%). If the value is greater than 1.00, it is positive; if the value is less than 1.00, it is negative. (e.g. F401=0.5 represents -50%). The corresponding setting benchmark: in the mode of combined speed control, analog is the accessorial frequency and the setting benchmark for range of accessorial frequency which relates to main frequency is “main frequency X”; corresponding setting benchmark for other cases is the “max frequency”, as illustrated in the right figure:



Relations of analog given and setting value

$A = (F401-1) * \text{setting value}$ $B = (F403-1) * \text{setting value}$ $C = F400$ $D = F402$

F406	Lower limit of AI2 channel input (V)	Setting range: 0.00~F408	Mfr's value: 0.04
F407	Corresponding setting for lower limit of AI2 input	Setting range: 0.00~2.00	Mfr's value: 1.00
F408	Upper limit of AI2 channel input (V)	Setting range: F406~10.00	Mfr's value: 10.00
F409	Corresponding setting for upper limit of AI2 input	Setting range: 0.00~2.00	Mfr's value: 2.00
F410	AI2 channel proportional gain K2	Setting range: 0.0~10.0	Mfr's value: 1.0
F411	AI2 filtering time constant (S)	Setting range: 0.10~10.00	Mfr's value: 0.1

The function of AI2 is the same with AI1.

F418	AI1 channel 0Hz voltage dead zone	Setting range: 0~1.00	Mfr's value: 0.00
F419	AI2 channel 0Hz voltage dead zone	Setting range: 0~1.00	Mfr's value: 0.00

Analog input voltage 0-5V can correspond to output frequency -50Hz-50Hz (2.5V corresponds to 0Hz) by setting the function of corresponding setting for upper / lower limit of analog input. The group function codes of F418 and F419 set the voltage range corresponding to 0Hz. For example, when F418=0.5 and F419=0.5, the voltage range from (2.5-0.5=2) to (2.5+0.5=3) corresponds to 0Hz. So if F418=N, F419=N, then 2.5±N should correspond to 0Hz. If the voltage is in this range, inverter will output 0Hz.

0Hz voltage dead zone will be valid when corresponding setting for lower limit of input is less than 1.00.

AO1, AO2 are provided as two analog output channels for EM30 series.

F423	AO1 output range	0: 0~5V; 1: 0~10V or 0~20mA 2: 4~20mA	Mfr's value: 1
F424	AO1 lowest corresponding frequency (Hz)	Setting range: 0.0~F425	Mfr's value: 0.05
F425	AO1 highest corresponding frequency (Hz)	Setting range: F424~F111	Mfr's value: 50.00
F426	AO1 output compensation (%)	Setting range: 0~120	Mfr's value: 100

AO1 output range is selected by F423. When F423=0, AO1 output range selects 0-5V, and when F423=1, AO1 output range selects 0-10V or 0-20mA. When F423=2, AO1 output range selects 4-20mA (When AO1 output range selects current signal, please turn the switch J5 to “I” position)

Correspondence of output voltage range (0-5V or 0-10V) to output frequency is set by F424 and F425. For example, when F423=0, F424=10 and F425=120, analog channel AO1 outputs 0-5V and the output frequency is 10-120Hz.

· AO1 output compensation is set by F426. Analog excursion can be compensated by setting F426.

F427	AO2 output range	Setting range: 0: 0~20mA; 1: 4~20mA	Mfr's value: 0
------	------------------	---	----------------

F428	AO2 lowest corresponding frequency (Hz)	Setting range: 0.0~F429	Mfr's value: 0.05
F429	AO2 highest corresponding frequency (Hz)	Setting range: F428~F111	Mfr's value: 50.00
F430	AO2 output compensation (%)	Setting range: 0~120	Mfr's value: 100

The function of AO2 is similar as AO1, but the output of AO2 is only current signal, 0-20mA or 4-20mA could be selected.

F431	AO1 analog output signal selecting	Setting range: 0: Running frequency; 1: Output current; 2: Output voltage; 3: AI1; 4: AI2 5: Input pulse 6: Output torque 7: Given by PC/PLC 8: Target frequency 9: Actual speed 10: Output torque 2 12: Output power 13: relay 2 output 14: Inlet pressure 15: Outlet pressure	Mfr's value: 0
F432	AO2 analog output signal selecting		Mfr's value: 1

· Token contents output by analog channel are selected by F431 and F432. Token contents include running frequency, output current and output voltage.

· When output current is selected, analog output signal is from 0 to twofold rated current.

· When output voltage is selected, analog output signal is from 0V to rated output voltage (230V or 400V).

· When actual speed is selected, the speed is actual speed in vector control mode, the speed is synchronous speed for the other mode.

· When relay 2 output is selected, AO1/AO2 will output the contents set by F302. For example: F302=1, F431=13, F423=1, analog output coding switch turns to voltage end, when fault occurs, AO1 output 10V, after fault reset, AO1 output 0V. When coding switch turns to current end, AO1 will output 0mA or 20mA.

14: it stands for the proportion between inlet pressure and inlet pressure full range.

15: it stands for the proportion between outlet pressure and outlet pressure full range.

F433	Corresponding current for full range of external voltmeter	Setting range: 0.01~5.00	Mfr's value: 2.00
F434	Corresponding current for full range of external ammeter		Mfr's value: 2.00

· In case of F431=1 and AO1 channel for token current, F433 is the ratio of measurement range of external voltage type ammeter to rated current of the inverter.

· In case of F432=1 and AO2 channel for token current, F434 is the ratio of measurement range of external current type ammeter to rated current of the inverter.

For example: measurement range of external ammeter is 20A, and rated current of the inverter is 8A, then, F433=20/8=2.50.

F435	Corresponding multiple of rated power for output max analog value	Setting range: 0.01~3.00	Mfr's value: 2.00
------	---	-----------------------------	-------------------

· Analog output range is taken as 0.01~3.00 times of torque power.

F436	corresponding current multiple of rated torque for output max analog value	Setting range: 0.01~3.00	Mfr's value: 3.00
------	--	-----------------------------	-------------------

In vector control, when token torque current, the analog output token range is 0.01~3.00 multiple of torque current.

F438 Input Signal of AI1 Channel	Setting range: 0: Voltage 1: Current	Mfr's value: 0
F439 Input Signal of AI2 Channel	Setting range: 0: Voltage 1: Current	Mfr's value: 1

When F438=0, AI1 channel is voltage signal input, when F438=1, AI1 channel is current signal input.

When F439=0, AI1 channel is voltage signal input, when F439=1, AI1 channel is current signal input.

The input signal should be matched with this parameter setting, and coding switch should be referred to Table 5-2 and 5-3.

5.5 Pulse Input and Output Control

F440 Min frequency of input pulse FI (KHz)	Setting range: 0.00~F442	Mfr's value: 0.00
F441 Corresponding setting of FI min frequency	Setting range:0.00~2.00	Mfr's value: 1.00
F442 Max frequency of input pulse FI (KHz)	Setting range: F440~100.00	Mfr's value: 10.00
F443 Corresponding setting of FI max frequency	Setting range: Max (1.00, F441) ~2.00	Mfr's value: 2.00
F445 Filtering constant of FI input pulse	Setting range: 0~1000	Mfr's value: 0
F446 FI channel 0Hz frequency dead zone (KHz)	Setting range: 0~F442 (Positive-Negative)	Mfr's value: 0.00
F448 FI Proportion Gain	Setting range: 0.001~2.000	Mfr's value: 1.000

· When inverter is controlled by pulse frequency, DI1 is defined as pulse signal input port automatically.

· Min frequency of input pulse is set by F440 and max frequency of input pulse is set by F442.

For example: when F440=0K and F442=10K, and the max frequency is set to 50Hz, then input pulse frequency 0-10K corresponds to output frequency 0~50Hz.

· Filtering time constant of input pulse is set by F445.

The greater the filtering time constant is, the more steady pulse measurement, but precision will be lower, so please adjust it according to the application situation.

· Corresponding setting of min frequency is set by F441 and corresponding setting of max frequency is set by F443.

When the max frequency is set to 50Hz, pulse input 0-10K can corresponds to output frequency -50Hz-50Hz by setting this group function codes. Please set F441 to 0 and F443 to 2, then 0K corresponds to -50Hz, 5K corresponds to 0Hz, and 10K corresponds to 50Hz. The unit of corresponding setting for max/min pulse frequency is in percentage (%). If the value is greater than 1.00, it is positive; if the value is less than 1.00, it is negative.

If the running direction is set to forward running by F202, 0-5K corresponding to the minus frequency will cause reverse running, or vice versa.

· 0 Hz frequency dead zone is set by F446.

Input pulse 0-10K can correspond to output frequency -50Hz~50Hz (5K corresponds to 0Hz) by setting the function of corresponding setting for max/min input pulse frequency. The function code F446 sets the input pulse range corresponding to 0Hz. For example, when F446=0.5, the pulse range from (5K-0.5K=4.5K) to (5K+0.5K=5.5K) corresponds to 0Hz. So if F446=N, then $5\pm N$ should correspond to 0Hz. If the pulse is in this range, inverter will output 0Hz.

0Hz voltage dead zone will be valid when corresponding setting for min pulse frequency is less than 1.00.

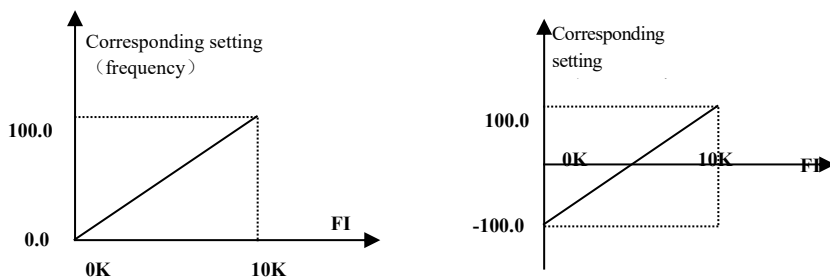

Fig 5-14 correspondence of pulse input and setting

The unit of corresponding setting for max/min input pulse frequency is in percentage (%). If the value is greater than 1.00, it is positive; if the value is less than 1.00, it is negative. (e.g. F441=0.5 represents -50%). The corresponding setting benchmark: in the mode of combined speed control, pulse input is the accessorial frequency and the setting benchmark for range of accessorial frequency which relates to main frequency (F205=1) is "main frequency X"; corresponding setting benchmark for other cases is the "max frequency", as illustrated in the right figure:

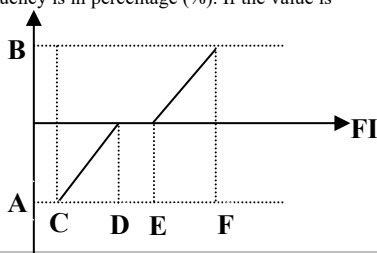

Fig 5-15 relationship between pulse input and setting value

$$A = (F441-1) * \text{setting benchmark}$$

$$B = (F443-1) * \text{setting benchmark}$$

$$C = F440$$

$$F = F442$$

$$(E-D)/2 = F446$$

F449 Max frequency of output pulse FO (KHz)	Setting range: 0.00~100.00	Mfr's value: 10.00
F450 Zero bias coefficient of output pulse frequency (%)	Setting range: 0.0~100.0	Mfr's value: 0.0
F451 Frequency gain of output pulse	Setting range: 0.00~10.00	Mfr's value: 1.00
F453 Output pulse signal	Setting range: 0: Running frequency 1: Output current 2: Output voltage 3: AI1 4: AI2 5: Input pulse 6: Output torque 7: Given by PC/PLC 8: Target frequency 9: Actual speed 10: Output torque 2 12: Output power 13: Relay 2 output 14: Inlet pressure 15: Outlet pressure	Mfr's value: 0

- When DO1 is defined as high-speed pulse output terminal, the max frequency of output pulse is set by F449.
- If “b” stands for zero bias coefficient, “k” stands for gain, “Y” stands for actual output of pulse frequency and “X” stands for standard output, then $Y=Kx+b$.
- Standard output X is the token value corresponding to output pulse min/max frequency, which range is from zero to max value.
- 100 percent of zero bias coefficient of output pulse frequency corresponds to the max output pulse frequency (the set value of F449.)
- Frequency gain of output pulse is set by F451. User can set it to compensate the deviation of output pulse.
- Output pulse token object is set by F453. For example: running frequency, output current and output voltage, etc. When output current is displayed, the range of token output is 0-2 times of rated current.
- When output voltage is displayed, the range of token output is 0-1.2 times of rated output voltage.

F460	All channel input mode	Setting range: 0: straight line mode 1: folding line mode	Mfr's value: 0
F461	A12 channel input mode	Setting range: 0: straight line mode 1: folding line mode	Mfr's value: 0
F462	All insertion point A1 voltage value (V)	Setting range: F400~F464	Mfr's value: 2.00
F463	A11 insertion point A1 setting value	Setting range: F401~F465	Mfr's value: 1.20
F464	A11 insertion point A2 voltage value (V)	Setting range: F462~F466	Mfr's value: 5.00
F465	A11 insertion point A2 setting value	Setting range: F463~F467	Mfr's value: 1.50
F466	A11 insertion point A3 voltage value (V)	Setting range: F464~F402	Mfr's value: 8.00
F467	A11 insertion point A3 setting value	Setting range: F465~F403	Mfr's value: 1.80
F468	A12 insertion point B1 voltage value (V)	Setting range: F406~F470	Mfr's value: 2.00
F469	A12 insertion point B1 setting value	Setting range: F407~F471	Mfr's value: 1.20
F470	A12 insertion point B2 voltage value (V)	Setting range: F468~F472	Mfr's value: 5.00
F471	A12 insertion point B2 setting value	Setting range: F469~F473	Mfr's value: 1.50
F472	A12 insertion point B3 voltage value (V)	Setting range: F470~F408	Mfr's value: 8.00
F473	A12 insertion point B3 setting value	Setting range: F471~F409	Mfr's value: 1.80

When straight-line is selected as the analog channel input mode, please set it according to the parameters from F400 to F429. When folding line mode is selected, three points A1 (B1), A2 (B2) and A3 (B3) are inserted into the straight line, each of which can set the according frequency to input voltage. Please refer to the following figure 5-16:

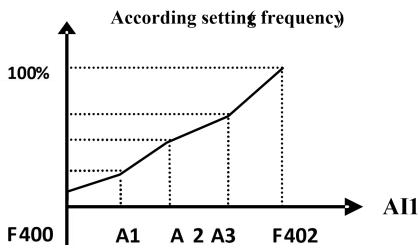

5-16 Folding analog with setting value

F400 and F402 are lower/upper limit of analog AI1 input. When F460=1, F462=2.00V, F463=1.4, F111=50, F203=1, F207=0, then A1 point corresponding frequency is $(F463-1) * F111=20\text{Hz}$, which means 2.00V corresponding to 20Hz. The other points can be set by the same way. AI2 channel has the same setting way as AI1.

F475 AO1 Output Bias	Setting range: 0~5.00	Mfr's value: 1.00
F476 AO2 Output Bias	Setting range: 0~5.00	Mfr's value: 1.00

·The value of F475 is to compensate the Min output current when AO1 is set as 4~20mA.

·The value of F476 is to compensate the Min output current when AO2 is set as 4~20mA.

5.6 Multi-stage Speed Control

The function of multi-stage speed control is equivalent to a built-in PLC in the inverter. This function can set running time, running direction and running frequency.

EM30 series inverter can realize 15-stage speed control and 8-stage speed auto circulating.

During the process of speed track, multi-stage speed control is invalid. After speed track is finished, inverter will run to target frequency according to the setting value of parameters.

F500	Stage speed type	Setting range: 0: 3-stage speed; 1: 15-stage speed; 2: Max 8-stage speed auto circulating	Mfr's value: 1
------	------------------	--	----------------

In case of multi-stage speed control (F203=4), the user must select a mode by F500. When F500=0, 3-stage speed is selected. When F500=1, 15-stage speed is selected. When F500=2, max 8-stage speed auto circulating is selected.

When F500=2, "auto circulating" is classified into "2-stage speed auto circulating", "3-stage speed auto circulating" ... "8-stage speed auto circulating", which is to be set by F501.

Table 5-6 Selection of Stage Speed Running Mode

F203	F500	Mode of Running	Description
4	0	3-stage speed control	The priority in turn is stage-1 speed, stage-2 speed and stage-3 speed. It can be combined with analog speed control. If F207=4, "3-stage speed control" is prior to analog speed control.
4	1	15-stage speed control	It can be combined with analog speed control. If F207=4, "15-stage speed control" is prior to analog speed control.
4	2	Max 8-stage speed auto circulating	Adjusting the running frequency manually is not allowable. "2-stage speed auto circulating", "3-stage speed auto circulating" ... "8-stage speed auto circulating" may be selected through setting the parameters.

F501	Selection of Stage Speed Under Auto-circulation Speed Control	Setting range: 2~8	Mfr's value: 7
F502	Selection of Times of Auto-circulation Speed Control	Setting range: 0~9999 (when the value is set to 0, the inverter will carry out infinite circulating)	Mfr's value: 0
F503	Status After Auto-circulation Running Finished.	Setting range: 0: Stop 1: Keep running at last-stage speed	Mfr's value: 0

- If running mode is auto-circulation speed control (F203=4 and F500=2), please set the related parameters by F501~F503.
- That the inverter runs at the preset stage speed one by one under the auto-circulation speed control is called as "one time".
- If F502=0, inverter will run at infinite auto circulation, which will be stopped by "stop" signal.
- If F502>0, inverter will run at auto circulation conditionally. When auto circulation of the preset times is finished continuously (set by F502), inverter will finish auto-circulation running conditionally. When inverter keeps running and the preset times is not finished, if inverter receives "stop command", inverter will stop. If inverter receives "run command" again, inverter will automatically circulate by the setting time of F502.

· If F503=0, then inverter will stop after auto circulation is finished. If F503=1, then inverter will run at the speed of the last-stage after auto-circulation is finished as follows:

e.g., F501=3, then inverter will run at auto circulation of 3-stage speed;

F502=100, then inverter will run 100 times of auto circulation;

F503=1, inverter will run at the speed of the last stage after the auto-circulation running is finished.

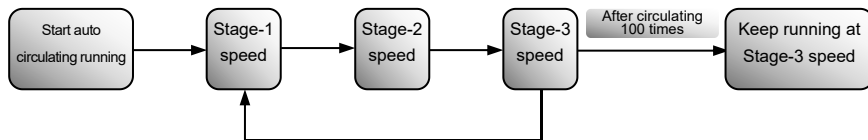

Figure 5-17 Auto-circulating Running

Then the inverter can be stopped by pressing “stop” or sending “stop” signal through terminal during auto-circulation running.

F504	Frequency setting for stage 1 speed (Hz)	Setting range: F112~F111	Mfr's value: 5.00
F505	Frequency setting for stage 2 speed (Hz)		Mfr's value: 10.00
F506	Frequency setting for stage 3 speed (Hz)		Mfr's value: 15.00
F507	Frequency setting for stage 4 speed (Hz)		Mfr's value: 20.00
F508	Frequency setting for stage 5 speed (Hz)		Mfr's value: 25.00
F509	Frequency setting for stage 6 speed (Hz)		Mfr's value: 30.00
F510	Frequency setting for stage 7 speed (Hz)		Mfr's value: 35.00
F511	Frequency setting for stage 8 speed (Hz)		Mfr's value: 40.00
F512	Frequency setting for stage 9 speed (Hz)		Mfr's value: 5.00
F513	Frequency setting for stage 10 speed (Hz)		Mfr's value: 10.00
F514	Frequency setting for stage 11 speed (Hz)		Mfr's value: 15.00
F515	Frequency setting for stage 12 speed (Hz)		Mfr's value: 20.00
F516	Frequency setting for stage 13 speed (Hz)		Mfr's value: 25.00
F517	Frequency setting for stage 14 speed (Hz)		Mfr's value: 30.00
F518	Frequency setting for stage 15 speed (Hz)	Mfr's value: 35.00	
F519~F533	Acceleration time setting for the speeds from Stage 1 to Stage 15 (S)	Setting range: 0.1~3000	Subject to inverter model
F534~F548	Deceleration time setting for the speeds from Stage 1 to Stage 15 (S)	Setting range: 0.1~3000	
F549~F556	Running directions of stage speeds from Stage 1 to Stage 8 (S)	Setting range: 0: forward running; 1: reverse running	Mfr's value: 0
F573~F579	Running directions of stage speeds from stage 9 to stage 15 (S)	Setting range: 0: forward running; 1: reverse running	Mfr's value: 0

F557 ~ 564 Running time of stage speeds from Stage 1 to Stage 8 (S)	Setting range: 0.1~3000	Mfr's value: 1.0
F565 ~ F572 Stop time after finishing stages from Stage 1 to Stage 8 (S)	Setting range: 0.0~3000	Mfr's value: 0.0

F580 Stage speed mode selection	Setting range: 0: Stage speed mode 1 1: Stage speed mode 2	Mfr's value: 0
---------------------------------	--	----------------

When F580=0, in 15-stage speed, terminal code status 0000 is invalid status, 1111 is 15th stage speed.

When F580=1, in 15-stage speed, terminal code status 0000 is 1st stage speed, and 1111 is invalid status.

5.7 Auxiliary Functions

F600 DC Braking Function Selection	Setting range: 0: Invalid; 1: braking before starting; 2: braking during stopping; 3: braking during starting and stopping	Mfr's value: 0
F601 Initial Frequency for DC Braking (Hz)	Setting range: 0.20~50.00	Mfr's value: 1.00
F602 DC Braking efficiency before Starting	Setting range: 0~250	Mfr's value: 50
F603 DC Braking efficiency During Stop		Mfr's value: 100
F604 Braking Lasting Time Before Starting (S)	Setting range: 0.00~30.00	Mfr's value: 0.50
F605 Braking Lasting Time During Stopping (S)		
F656 DC braking waiting time during stopping(s)	Setting range: 0.00~30.00	Mfr's value: 0

When F600=0, DC braking function is invalid.

When F600=1, braking before starting is valid. After the right starting signal is input, inverter starts DC braking. After braking is finished, inverter will run from the initial frequency.

In some application occasion, such as fan, motor is running at a low speed or in a reverse status, if inverter starts immediately, OC malfunction will occur. Adopting “braking before starting” will ensure that the fan stays in a static state before starting to avoid this malfunction.

During braking before starting, if “stop” signal is given, inverter will stop by deceleration time.

When F600=2, DC braking during stopping is selected. After output frequency is lower than the initial frequency for DC braking (F601), DC braking will stop the motor immediately

During the process of braking during stopping, if “start” signal is given, DC braking will be finished and inverter will start.

If “stop” signal is given during the process of braking during stopping, inverter will have no response and DC braking during stopping still goes on.

When jogging function is valid, the function of braking before starting set by F600 is valid, and the function of speed track is invalid.

When jogging function is invalid and F613-1, the function of braking before starting is invalid.

Parameters related to “DC Braking”: F601, F602, F603, F604, F605, interpreted as follows:

- F601: Initial frequency of DC-braking. DC braking will start to work as inverter's output frequency is lower than this value.
- F602/F603: DC braking efficiency. The bigger value will result in a quick braking. However, motor will overheat with too big value.
- F604: Braking duration before starting. The time lasted for DC braking before inverter starts.
- F605: Braking duration when stopping. The time lasted for DC braking while inverter stops.

Note: during DC braking, because motor does not have self-cold effect cause by rotating, it is in the state of easy over-heat. Please do not set DC braking voltage too high and do not set DC braking time to long.

DC braking, as shown in Figure 5-18.

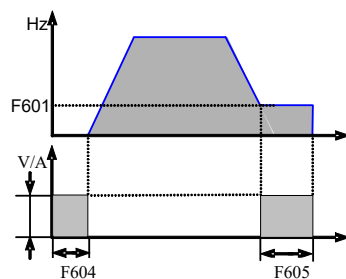

Figure 5-18 DC braking

F606 DC Braking Mode	Setting range: 0: Voltage mode 1: Current mode	Mfr's value: 1
----------------------	--	----------------

F607 Selection of Stalling Adjusting Function	Setting range: 0~2:Reserved 3: Voltage/current control 4: Voltage control 5: Current control	Mfr's value: 3
F608 Stalling Current Adjusting (%)	Setting range: 60~FC49	Mfr's value: 160
F609 Stalling Voltage Adjusting (%)	Setting range: 110~200	Mfr's value: 1-phase 220V: 130 3-phase 380V: 140
F610 Stalling protection judgment time(S)	Setting range: 0.0: disabled 0.1~3000.0	Mfr's value: 0.0

F607 is used to set selection of stalling adjusting function.

Voltage control: when motor stops quickly or load changes suddenly, DC bus voltage will be high. Voltage control function can adjust deceleration time and output frequency to avoid OE.

When braking resistor or braking unit is used, please do not use voltage control function. otherwise, the deceleration time will be changed.

Current control: when motor accelerates quickly or load changed suddenly, inverter may trip into OC. Current control function can adjust accel/decel time or decrease output frequency to control proper current value. It is only valid in VF control mode.

Note: (1) Voltage/current control is not suitable for lifting application.

(2) This function will change accel/decel time. Please use this function properly.

(3) Please do not use this function when one inverter drives two motors.

Initial value of stalling current adjusting is set by F608, when the present current is higher than rated current *F608, stalling current adjusting function is valid.

During the process of deceleration, stalling current function is invalid.

During the process of acceleration, if output current is higher than initial value of stalling current adjusting and F607=1, then stalling adjusting function is valid. Inverter will not accelerate until the output current is lower than initial value of stalling current adjusting.

In case of stalling during stable speed running, the frequency will drop. If the current returns to normal during dropping, the frequency will return to rise. Otherwise, the frequency will keep dropping to the minimum frequency and the protection OL1 will occur after it lasts for the time as set in F610.

Initial value of stalling voltage adjusting is set by F609, when the present voltage is higher than rated voltage *F609, stalling voltage adjusting function is valid.

Stalling voltage adjusting is valid during the process of deceleration, including the deceleration process caused by stalling current.

Note:

When F610=0, inverter will not stop running and display OL1.

During stalling voltage adjusting, if customer presses STOP for 3 seconds, the inverter will be forced to stop

FB06 Current Limit Coefficient	Setting range: 0~200	Mfr's value: 60
FB07 Voltage Limit Proportion Coefficient	Setting range: 0~100	Mfr's value: 30
FB08 Voltage Limit Integral Coefficient	Setting range: 0~100	Mfr's value: 30

·FB06 is to set the response time of current limit. If the value is bigger, the response is faster. But it is possible to cause current shock.

·FB07 and FB08 is to set the response time of voltage limit. If the value is bigger, the response is faster. But it is possible to cause voltage shock.

F611 Dynamic Braking threshold (V)	Setting range: 320~2000	Subject to inverter model
F612 Dynamic braking duty ratio (%)	Setting range: 0~100	Mfr's value: 100

Initial voltage of dynamic braking threshold is set by F611, which of unit is V. When DC bus voltage is higher than the setting value of this function, dynamic braking starts, braking unit starts working. After DC bus voltage is lower than the setting value, braking unit stops working.

Dynamic braking duty ratio is set by F612, the range is 0~100%. The value is higher, the braking effect is better, but the braking resistor will get hot.

F613 Speed track	Setting range: 0: Invalid 1: Valid for induction motor 2: Valid for induction motor at the first time 3: Mode 1 for PM motor 4: Mode 2 for PM motor	Mfr's value: 0
------------------	--	----------------

When F613=0, the function of speed track is invalid.

When F613=1, the function of speed track is valid for induction motor.

After inverter tracks motor speed and rotating direction, inverter will start the rotating motor smoothly. This function is suitable for the situation of re-starting after repowered on, re-starting after reset, re-starting when running command valid but direction signal lost, and re-starting when running command invalid.

When F613=2, the function is valid at the first time after inverter is repowered on or reset.

When F613=3, it is suitable for PM motor of low-inertia load

When F613=4, it is suitable for PM motor of high-inertia load

F614 Speed track mode	Setting range: 0: Speed track from frequency memory 1: Speed track from max frequency 2: Speed track from zero	Mfr's value: 0
-----------------------	---	----------------

When F614 is set to 0, inverter will track speed down from frequency memory.

When F614 is set to 1, inverter will track speed up from max frequency.

When F614 is set to 2, inverter will track speed down from 0Hz.

F615 Speed track rate	Setting range: 1~100	Mfr's value: 20
-----------------------	----------------------	-----------------

It is used to select the rotation velocity speed track when the rotation tracking restart mode is adopted. The larger the parameter is, the faster the speed track is. But if this parameter is too large, it likely results in unreliable tracking.

F618 Delay Time of Speed Track (S)	Setting range: 0.5~60.0	Mfr's value: 1.5
------------------------------------	-------------------------	------------------

When speed tracking is enable, inverter will start to track speed after delaying time.

F620 Brake delay turn-off time	Setting range: 0.0 (Bleed not closed when stop) 0.1~3000	Mfr's value: 5.0
--------------------------------	--	------------------

F620=0, dynamic brake is not closed in stop status, it starts when PN voltage is higher than brake point;
F620≠0, dynamic brake can proceed normally when inverter is running, the time set by F620 is the delay time after stop, then the dynamic brake closes automatically.

F631 DC BUS Voltage adjusting	Setting range: 0: Invalid 1: Valid at steady speed 2: Reserved 3: Always valid	Mfr's value: 0
F632 Reference Voltage of DC BUS adjusting (V)	Setting range: 100~2300	Subject to inverter model
F633 Range for DC BUS adjusting(Hz)	Setting range: 0~100.00	Mfr's value: 5.00
F634 Accelerating Time for DC BUS adjusting(S)	Setting range: 0.1~3000.0	Mfr's value: 0.1
F635 Decelerating Time for DC BUS adjusting(S)	Setting range: 0.1~3000.0	Mfr's value: 0.1
F636 Proportion Gain for DC BUS adjusting	Setting range: 0.01~20.00	Mfr's value: 1.00
F637 Integral Gain for DC BUS adjusting	Setting range: 0~20.00	Mfr's value: 1.50

·When F631=1, DC BUS adjusting is only valid at steady speed.

·When F631=3, DC BUS adjusting is always valid.

·When the DC BUS voltage exceeds F632 at running status, adjusting starts to work.

F633 is the max adjusting range of frequency. If over-voltage trip often happens, customer can increase this value.

F634 normally is 0.1s. F635 can be set according to the actual operation.

The bigger value of F636 and F637 is, the faster of response time is.

Note: If this function is used, it is better to switch off voltage limit function(F607=0 or 5).

F638 Parameters copy enabled	Setting range: 0: Copy forbidden 1: Parameters copy 1 2: Parameters copy 2 3: parameters copy 3 4: Parameters copy 4	Mfr's value: 1
F639 Parameters copy code		Subject to software version
F640 Parameter copy type	Setting range: 0: Copy all parameters 1: Copy parameters except motor parameters from F801 to F810/F844.	Mfr's value: 1

Please refer to the user manual of parameters copy.

F638 value	Parameter copy code	Rated voltage & Power
Parameter copy 1	Should be same	Should be same
Parameter copy 2	Should be same	No need to be same
Parameter copy 3	No need to be same	Should be same
Parameter copy 4	No need to be same	No need to be same

Note: When the parameter copy code is not same, possibly the copied parameter is not correct or out of range.

The related fault in the process of parameters copy is in the table below:

Code	Causes
Er71 Copy timeout	During copying process, there is no valid data after 3s.
Er72 Copy when running	Parameters copy when inverter is in the running status.
Er73 Copy without input password	Password is valid and user does not input password.
Er74 Copy between different models	If copy code, or voltage level or power is different, copy is forbidden.
Er75 Copy forbidden	Parameters copy when F638=0

F641 Inhibition gain of low frequency oscillation	0~100 0: Invalid	Subject to inverter model
---	---------------------	---------------------------

F641 is used for setting the inhibition ability of low frequency oscillation.

When F641=0, inhibition function is invalid.

In the V/F control mode, if inhibition of low frequency oscillation is valid, the following parameters are needed to be set.

(1) F106=2 (V/F control mode) and F137≤2;

(2) F613=0, the speed track function is invalid.

Note:

1. When F641=1, one inverter can only drive one motor one time.

2. When F641=1, please set motor parameters (F801~F805, F844) correctly.

3. When inhibition oscillation function is invalid, and inverter runs without motor, output voltage may be unbalanced. This is normal situation. After inverter runs with motor, output voltage will be balanced.

F644 Keypad Copy enabled	Setting range: 0: Invalid 1: current macro parameter upload 2: current macro parameter download 3: user macro 1 upload 4: user macro 1 download 5: user macro 2 upload 6: user macro 2 download	Mfr's value: 0
--------------------------	--	----------------

· Keypad copy is only valid in LCD keypad.

· In stop status, after saving user macro 1/2 parameters and setting F644=1, press “Run” key, inverter will enter parameter upload interface, all parameters of macro will be upload to keypad. When F644=3, user macro 1 parameters will be upload. When F644=5, user macro 2 parameters will be upload. After upload,

when F644=2, parameters will be download to current user macro and cover the current parameters. When F644=4, parameters will be download to user macro1 and cover the parameters of macro 1. After setting F644=6, parameters will be download to user macro 2 and cover the parameters of macro 2.

F645 Status parameters selection	0	Running frequency
	1	Rotation speed
	2	Target speed
	3	Output current
	4	Output voltage
	5	DC bus voltage
	6	PID setting value
	7	PID feedback value
	8	Radiator temperature
	9	Count value
	10	Linear speed
	11	Channel for main frequency
	12	Main frequency
	13	Channel for accessorial frequency
	14	Accessorial frequency
	17	Output torque
	18	Setting torque
	19	Motor power
	20	Output power
	21	Running status
	22	DI terminal status
	23	Output terminal status
	24	Stage speed of multi-stage speed
	25	AI1 input value
	26	AI2 input value
	28	Reserved
	29	Pulse input frequency
	30	Pulse output frequency
	31	AO1 output percent
	32	AO2 output percent
	33	Power on Hours
	36	Current lighting

User can change the display of first two lines in the operation/halt interface by setting F645.

F646 Backlight time of LCD (S)	Setting range: 0~100	Mfr's value: 100
--------------------------------	----------------------	------------------

Change the duration of backlight by setting F646. F646=0, LCD light is always off; F646=100, LCD light is always on. Press 1~99 is the duration time of LCD backlight.

F647 Language selection	Setting range: 0: Chinese 1: English 2: Deutsch 3: Espanol 4: Francais	Mfr's value: 0
-------------------------	---	----------------

Change display language by setting F647, the default value is Chinese.

F657 Instantaneous Power Failure Selection	Setting range: 0: Invalid 1: Non-stop after power failure 2: Decelerate to stop after power failure 3: Decelerate to stop by DI control after power failure	Mfr's value: 0
--	---	----------------

When F657=1, upon instantaneous power failure or sudden voltage dip, the function enables the inverter to compensate the DC bus voltage reduction with the load feedback energy by reducing the output frequency so as to keep the inverter running continuously.

When F657=2, upon instantaneous power failure or sudden voltage dip, the frequency will decrease rapidly and inverter will decelerate to stop.

When F657=3, firstly the function of one DI terminal(F316~F323) is set as 43, i.e. Decelerate to Stop at power failure. If the DI terminal is valid, inverter will decelerate to stop at instantaneous power failure. The action is same as F657=2.

Note: 1. F663 and F664 are related parameters, please increase them properly.

2. This function is not suitable for the application of heavy load and small inertial load.

F658 Voltage Rally Acceleration Time (S)	Setting range: 0.0~3000 0.0: F114	Mfr's value: 0.0
F659 Voltage Rally Deceleration Time (S)	Setting range: 0.0~3000 0.0: F115	Mfr's value: 0.0
F660 Action Judging Voltage at Instantaneous Power Failure (V)	Setting range: 200~F661	Subject to inverter model
F661 Action Stop Voltage at Instantaneous Power Failure (V)	Setting range: F660~1400	Subject to inverter model
F662 Instantaneous Voltage Recovery Judging Time(s)	Setting range: 0.00~10.00	Mfr's value: 0.30
F663 Instantaneous Proportion Coefficient Kp	Setting range: 0.00~10.00	Mfr's value: 0.25
F664 Instantaneous Integral Coefficient Ki	Setting range: 0.00~10.00	Mfr's value: 0.30
F751 Instantaneous Stop Pretreatment Enable	Setting range: 0: Invalid 1: Valid	Mfr's value: 0

· Upon instantaneous power failure or sudden voltage dip, the DC bus voltage of the inverter reduces. The function enables the inverter to compensate the DC bus voltage reduction with the load feedback energy by reducing the output frequency so as to keep the inverter running continuously.

· The function is suitable for big inertia load, such as, fan and centrifugal pump.

· The function is not suitable for the application which frequency is forbidden being decreased.

· When the power supply is recovered, F658/F659 are used to set the accel/decel time when inverter runs to target frequency.

· When instantaneous function is valid, if PN voltage is lower than F660, instantaneous function works.

· When inverter is at instantaneous status, if PN voltage is higher than F661, the bus voltage remains to normal, inverter will quit the instantaneous function and return to target frequency.

· When the power supply is recovered, after the duration of F662, inverter will quit the instantaneous function and return to target frequency.

When F751=1, if inverter detect that the PN voltage drops rapidly, inverter will decelerate in advance so that it can generate electric power before undervoltage.

F670 Voltage-limit current-limit adjustment coefficient	Setting range: 0.01~10.00	Mfr's value: 2.00
---	---------------------------	-------------------

Lower this factor properly if frequent over-voltage protection occurs in the process of deceleration; Increase the factor when deceleration is too slow.

F671 voltage source for V/F separation	Setting range: 0: F672 1: AI1 2: AI2 4: Communication setting 5: Pulse setting 6: PID given 7~10: reserved	Mfr's value: 0
F672 Voltage digital setting for V/F separation	Setting range: 0.00~100.00	Mfr's value: 100.0

F671 is 100% of the setting corresponds to the rated motor voltage.

F671=0: Digital setting, the output voltage is set by F672.

F671=1: AI1; F671=2:AI2; the output voltage is set by analog.

F671=4: Communication setting

The output voltage is set by PC/PLC, the communication address is 2009H, the given range is 0~10000, which means 0~100% of rated voltage.

F671=5 pulse setting

The output voltage is set by external high-speed pulse. The input frequency of pulse corresponds to motor rated voltage.

F671=6: PID given

The output voltage is set by PID. PID adjustment corresponds to 100% of motor rated voltage. For details, please refer to PID parameters group.

F671=7~10: Reserved.

F673 Lower limit of voltage at V/F separation (%)	Setting range: 0.00~F674	Mfr's value: 0.00
F674 Upper limit of voltage at V/F separation (%)	Setting range: F673~100.00	Mfr's value: 100.00

When the voltage is lower than F673, the voltage should equal to F673. When the voltage is higher than F674, the voltage should equal to F674.

F675 Voltage rise time of V/F separation (S)	Setting range: 0.0~3000.0	Mfr's value: 5.0
F676 Voltage decline time of V/F separation (S)	Setting range: 0.0~3000.0	Mfr's value: 5.0

F675 is the time required for the output voltage to rise from 0V to the rated motor voltage.

F676 is the time required for the output voltage to decline from the rated motor voltage to 0V.

F677 Stop mode at V/F separation	Setting range: 0: voltage and frequency declines to 0 according to respective time. 1: Voltage declines to 0 firstly 2: Frequency declines to 0 firstly.	Mfr's value: 0
----------------------------------	---	----------------

When F677 = 0, voltage and frequency declines to 0 according to respective time, inverter will stop when frequency declines to 0.

When F677 = 1, voltage will decline to 0 at first. After voltage is 0, frequency will decline to 0.

When F677 = 2, frequency will decline to 0 at first. After frequency is 0, voltage will decline to 0.

F678 Judgment Voltage at V/F Separation	Setting range: 0: Invalid 1: Auto judgment	Mfr's value: 0
F679 Voltage Switch Point at V/F Separation(V)	Setting range: 200 ~ 600	Mfr's value: 430
F680 Switch Point Width at V/F Separation (%)	Setting range: 0.0~100.0	Mfr's value: 0.5

When F678=0, judgment voltage is invalid.

When F678=1, input voltage is judged automatically. When input voltage is higher than (F679 +F679*F680), the current input voltage is judged to T3 380V. If lower, the voltage is judged to S2 220V.

5.8 Malfunction and Protection

F700 Selection of terminal free stop mode	Setting range: 0: free stop immediately; 1: delayed free stop	Mfr's value: 0
F701 Delay time for free stop and programmable terminal action	Setting range: 0.0~60.0	Mfr's value: 0.0

· “Selection of free stop mode” can be used only for the mode of “free stop” controlled by the terminal. The related parameters setting is F201=1, 2, 4 and F209=1.

· F700=0: “free stop immediately”, delay time (F701) is invalid and inverter will free stop immediately.

· “Delayed free stop” means that upon receiving “free stop” signal, the inverter will execute “free stop” command after waiting some time instead of stopping immediately. Delay time is set by F701. During the process of speed track, the function of delayed free stop is invalid.

F702 Fan control mode	0: controlled by temperature 1: Running when inverter is powered on. 2: controlled by running status	Mfr's value: 2
-----------------------	--	----------------

When F702=0, fan will run if radiator's temperature is up to preset temperature.

When F702=2, fan will run when inverter begins running. When inverter stops, fan will stop according to radiator's temperature.

F704 Inverter Overloading pre-alarm Coefficient (%)	Setting range: 50~100	Mfr's value: 80
F705 Motor Overloading pre-alarm Coefficient (%)	Setting range: 50~100	Mfr's value: 80
F706 Inverter Overloading Coefficient (%)	Setting range: 120~190	Mfr's value: 150
F707 Motor Overloading Coefficient (%)	Setting range: 20~100	Mfr's value: 100

· Inverter overloading coefficient: the ratio of overload-protection current and rated current, which value shall be subject to actual load.

· Motor overloading coefficient (F707): when inverter drives lower power motor, please set the value of F707 by below formula in order to protect motor.

Motor Overloading Coefficient=(Actual motor rated current)/(Inverter rated current)*100%

Please set F707 according to actual situation. The lower the setting value of F707 is, the faster the overload protection speed. Please refer to Fig 5-19.

E.g. 7.5kW inverter(rated current 17A) drives 5.5kW motor(rated current 12A), F707=12/17*100%≈70%

When the actual current of motor reaches 140% of inverter rated current, inverter overload protection will display after 1 minute.

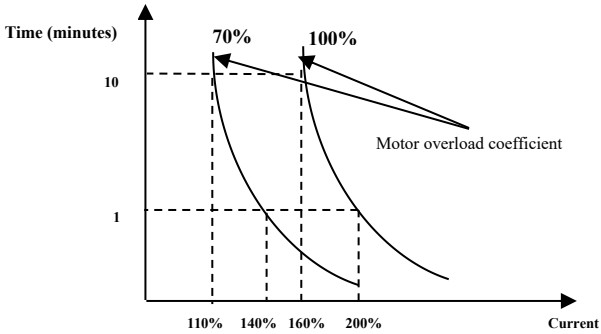

Fig 5-19 Motor overload coefficient

When the output frequency is lower than 10Hz, the heat dissipation effect of common motor will be worse. So when running frequency is lower than 10Hz, the threshold of motor overload value will be reduced. Please refer to Fig 5-20 (F707=100%):

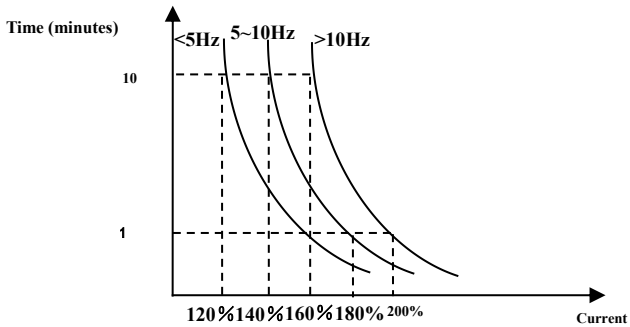

Fig 5-20 Motor overload protection value

F708	Record of The Latest Malfunction Type	Setting range: Please refer to Appendix 1.	
F709	Record of Malfunction Type for Last but One		
F710	Record of Malfunction Type for Last but Two		
F711	Fault Frequency of The Latest Malfunction (Hz)		
F712	Fault Current of The Latest Malfunction (A)		
F713	Fault PN Voltage of The Latest Malfunction (V)		
F714	Fault Frequency of Last Malfunction but One(Hz)		
F715	Fault Current of Last Malfunction but One(A)		
F716	Fault PN Voltage of Last Malfunction but One (V)		
F717	Fault Frequency of Last Malfunction but Two(Hz)		

F718	Fault Current of Last Malfunction but Two (A)		
F719	Fault PN Voltage of Last Malfunction but Two (V)		
F720	Record of over current protection fault times		
F721	Record of overvoltage protection fault times		
F722	Record of overheat protection fault times		
F723	Record of overload protection fault times		
F724	Input phase loss	Setting range: 0: invalid; 1: valid	Subject to inverter model
F725	Under-voltage protection	Setting range: 1: reset manually 2: reset automatically	Mfr's value: 2
F726	Overheat	Setting range: 0: invalid; 1: valid	Mfr's value: 1
F727	Output phase loss	Setting range: 0: invalid; 1: valid	Mfr's value: 1
F728	Input phase loss filtering constant (S)	Setting range: 1~60	Mfr's value: 5
F729	Under-voltage filtering constant (2mS)	Setting range: 1~3000	Mfr's value: 5
F730	Overheat protection filtering constant (S)	Setting range: 0.1~60.0	Mfr's value: 5.0
F732	Under-voltage protection voltage threshold	Subject to inverter model	Subject to inverter model

“Under-voltage” refers to too low voltage at AC input side.

“Input phase loss” refers to phase loss of three-phase power supply.

“Output phase loss” refers to phase loss of inverter three-phase wirings or motor wirings.

F737	Over-current 1 protection	Setting range: 0:Invalid 1: Valid	Mfr's value: 1
F738	Over-current 1 protection coefficient	Setting range: 0.50~3.00	Mfr's value: 2.5
F739	Over-current 1 protection record		

· F738= OC 1 value/inverter rated current

· In running status, F738 is not allowed to modify. When over-current occurs, OC1 is displayed.

F741	Analog disconnected protection	Setting range: 0: Invalid 1: Stop and AErr is displayed. 2: Stop and AErr is not displayed. 3: Inverter runs at the min frequency. 4: Switch to stage-speed circulation	Mfr's value: 0
F742	Threshold of analog disconnected protection (%)	Setting range: 1~100	Mfr's value: 50

When the values of F400 and F406 are lower than 0.01V, analog disconnected protection is invalid.

When F741 is set to 1, 2 or 3, the values of F400 and F406 should be set to 1V-2V, to avoid the error protection by interference.

Analog disconnected protection voltage=analog channel input lower limit * F742. Take the AI1 channel for the example, if F400=1.00, F742=50, then disconnection protection will occur when the AI1 channel

voltage is lower than 0.5V.

F745 Threshold of pre-alarm overheat (%)	Setting range: 0~100	Mfr's value: 80
F746 Carrier frequency auto-adjusting threshold	Setting range: 60~100	Mfr's value: 75
F747 Carrier frequency auto-adjusting enable	Setting range: 0: Invalid 1: Valid	Mfr's value: 1

When the temperature of radiator reaches 90℃*F745 and multi-function output terminal is set to 16 (Please refer to F300~F302), it indicates inverter is in the status of overheat.

F746: Inverter will reduce carrier frequency when the temperature of inverter is higher than the setting temperature.

When F747=1, the temperature of radiator reaches certain temperature, inverter carrier frequency will adjust automatically, to decrease the temperature of inverter. This function can avoid overheat malfunction.

F752 Overload quitting coefficient	Setting range: 0.1~20.0	Mfr's value: 1.0
F753 Selection of overload protection	Setting range: 0: Normal motor 1: Variable frequency motor	Mfr's value: 1

·The bigger the setting value of F752 is, the faster the shortened overload cumulative time is.

·When F753=0, because heat dissipation effect of normal motor is bad in low speed, the electronic thermal protection value will be adjusted properly. It means overload protection threshold of motor will be decreased when running frequency is lower than 30Hz.

·When F753=1, because heat dissipation effect of variable frequency motor is not influenced by speed, there is no need to adjust the protection value.

F754 Zero-current threshold (%)	Setting range: 0~200	Mfr's value: 5
F755 Duration time of zero-current (S)	Setting range: 0.0~60.0	Mfr's value: 0.5

When the output current is fallen to zero-current threshold, and after the duration time of zero-current, ON signal is output.

F756 Delay time for DC bus voltage detection when drive runs (ms)	Setting range: 0: Invalid 1~5000	Mfr's value: 0
F757 Delay Time for DC bus voltage detection When Drive Stops (S)	Setting range: 0.0~100.0	Mfr's value: 5.0

·When F756=0, bus voltage base is not detected when voltage limiting.

When F756 ≠ 0, after SD close, bus voltage will be detected recurrently after setting delay time.

·After the drive stops, bus voltage will be detected recurrently after setting delay time. The detected value is saved in H016.

F759 Carrier-frequency Ratio	Setting range: 3~30	Mfr's value: 15
------------------------------	---------------------	-----------------

·Carrier frequency=running frequency *F759. When the product of running frequency and F759 is higher than carrier frequency, actual carrier frequency will be increased automatically, and it will not be limited by temperature control carrier frequency.

F760 Grounding Protection	Setting range: 0: Invalid 1: Valid when powering on 2: Valid during running 3: Valid both powering on and running	Mfr's value: subject to model
---------------------------	--	-------------------------------

When output terminals (U, V, W) are connected to the earth or the earth impedance is too low, then the leak current is high, inverter will trip into GP.

When F760=1, inverter will make grounding test for one time when it is powered on.

When F760=2, inverter will make grounding test for each time of running.

When F760=3, inverter will make grounding test for each time of power on and running.

Note: 3-phase 220V inverter does not have GP protection.

F761 Switchover mode of FWD/REV	Setting range: 0: At zero 1: at start frequency	Mfr's value: 0
---------------------------------	---	----------------

·When F761=0, FWD/REV switches at zero frequency, F120 is valid.

·When F761=1, FWD/REV switches at start frequency, F120 is invalid, if start frequency is too high, current shock will occur during switchover process.

F770 Auxiliary version No.		
----------------------------	--	--

·It only can be checked.

F776 Delay Time For Grounding Test (S)	Setting range: 0.0~3600.0	Mfr's value: 2.0
--	---------------------------	------------------

·When grounding protection is valid(F760), if the time interval between stop and start is less than F776, inverter will not enable grounding test.

F784 Over-modulation Coefficient of Output Voltage	Setting range: 100~110	Mfr's value:105
--	------------------------	-----------------

·When the output voltage reaches 100%, inverter could output more volt by setting F784.

5.9 Parameters of the Motor

F800	Motor's parameters tuning	Setting range: 0: Invalid; 1: Rotating tuning; 2: stationary tuning	Mfr's value: 0
F801	Rated power (kW)	Setting range: 0.1~1000.0	Subject to model
F802	Rated voltage (V)	Setting range: 1~1300	
F803	Rated current (A)	Setting range: 0.2~6553.5	
F804	Number of motor poles	Setting range: 2~100	Mfr's value: 4
F805	Rated rotary speed (rpm/min)	Setting range: 1~30000	
F810	Motor rated frequency (Hz)	Setting range: 1.0~590.0	Mfr's value: 50.00

·Please set the parameters in accordance with those indicated on the nameplate of the motor.

·Excellent control performance of vector control requires accurate parameters of the motor. Accurate parameter tuning requires correct setting of rated parameters of the motor.

·In order to get the excellent control performance, please configure the motor in accordance with adaptable motor of the inverter. In case of too large difference between the actual power of the motor and that of adaptable motor for inverter, the inverter's control performance will decrease remarkably.

·F800=0, parameter tuning is invalid. But it is still necessary to set the parameters F801~F803, F805 and F810 correctly according to those indicated on the nameplate of the motor.

After powered on, it will use default parameters of the motor (F806-F809) according to the motor power set at F801. This value is only a reference value in view of Y series 4-pole asynchronous motor.

·F800=1, rotating tuning.

In order to ensure dynamic control performance of the inverter, select "rotating tuning" after ensuring that the motor is disconnected from the load. Please set F801-805 and F810 correctly prior to running testing.

Operation process of rotating tuning: Press the "Run" key on the keypad to display "TEST", and it will tune the motor's parameter of two stages. After that, the motor will accelerate according to acceleration time set at F114 and maintain it for a certain period. The motor will then decelerate to 0 according to the time set at F115. After auto-checking is completed, relevant parameters of the motor will be stored in function codes F806~F809, and F800 will turn to 0 automatically.

·F800=2, stationary tuning.

It is suitable for the cases where it is impossible to disconnect the motor from the load.

Press the "Run" key, and the inverter will display "TEST", and it will tune the motor's parameter of two stages. The motor's stator resistance, rotor resistance and leakage inductance will be stored in F806-F809 automatically (the motor's mutual inductance uses default value generated according to the power), and F800 will turn to 0 automatically. The user may also calculate and input the motor's mutual inductance value manually according to actual conditions of the motor. With regard to calculation formula and method, please call us for consultation.

When tuning the motor's parameter, motor is not running but it is powered on. Please do not touch motor during this process.

*Note:

1. No matter which tuning method of motor parameter is adopted, please set the information of the motor (F801-F805) correctly according to the nameplate of the motor. If the operator is quite familiar with the motor, the operator may input all the parameters (F806-F809) of the motor manually.

2. Parameter F804 can only be checked, not be modified.

3. Incorrect parameters of the motor may result in unstable running of the motor or even failure of normal running. Correct tuning of the parameters is a fundamental guarantee of vector control performance. Each time when F801 rated power of the motor is changed, the parameters of the motor (F806-F809) will be refreshed to default settings automatically. Therefore, please be careful while amending this parameter. The motor's parameters may change when the motor heats up after running for a long time. If the load can be disconnected, we recommend auto-checking before each running.

F806 Stator resistance (Ω)	Setting range: 0.001~65.53 Ω (for 15kw and below 15kw) 0.1~6553m Ω (For above 15kw)	Subject to inverter model
F807 Rotor resistance (Ω)	Setting range: 0.001~65.53 Ω (for 152kw and below 15kw) 0.1~6553m Ω (For above 15kw)	
F808 Leakage inductance (mH)	Setting range: 0.01~655.3mH (for 15kw and below 15kw) 0.001~65.53mH (for above 15kw)	
F809 Mutual inductance (mH)	Setting range: 0.1~6553mH (for 15kw and below 15kw) 0.01~655.3mH (for above 15 kw)	
F844 Motor no-load current (A)	Setting range: 0.1~F803	

·The set values of F806~F809 will be updated automatically after normal completion of parameter tuning of the motor.

·If it is impossible to measure the motor at the site, input the parameters manually by referring to the known parameters of a similar motor.

F844 can be got automatically by rotating tuning.

If the no-load current is higher when motor is running, please decrease the value of F844.

If running current or start current is higher when motor is running with load, please increase the value of F844.

Take a 3.7kW inverter for the example: all data are 3.7kW, 400V, 8.8A, 1440rpm/min, 50Hz, and the load is disconnected. When F800=1, the operation steps are as below:

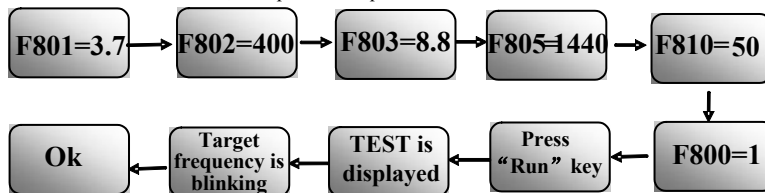

F811 Carrier Frequency Switchover Point (Hz)	Setting range: 0.00~20.00	Mfr's value: 8.00
--	---------------------------	-------------------

·When F811 = 0, there is no carrier frequency switchover.

·When F811 \neq 0, and frequency is lower than switchover point, carrier frequency is internal fixed carrier-frequency. When running frequency is higher than switchover point, carrier frequency will switch to setting carrier frequency.

F812	Pre-excitation time (S)	Setting range: 0.00~30.00	0.30
F813	Rotary speed loop KP1	Setting range: 1~100	30
F814	Rotary speed loop KI1	Setting range: 0.01~10.00	0.50
F815	Rotary speed loop KP2	Setting range: 1~100	Subject to inverter model
F816	Rotary speed loop KI2	Setting range: 0.01~10.00	1.00
F817	PID switching frequency 1	Setting range: 0~F818	5.00
F818	PID switching frequency 2	Setting range: F817~F111	10.00

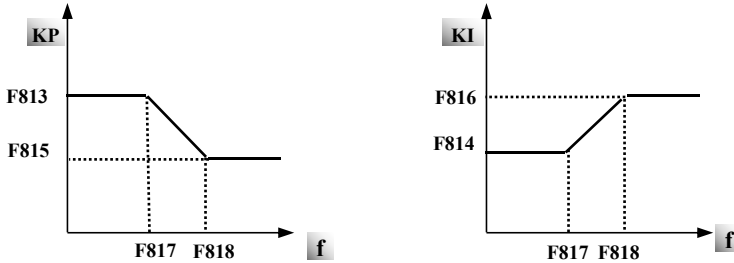

Fig 5-21 PI parameter sketch map

Dynamic response of vector control speed can be adjusted through adjusting proportional and storage gains of speed loop. Increasing KP and KI can speed up dynamic response of speed loop. However, if proportional gain or storage gain is too large, it may give rise to oscillation.

Recommended adjusting procedures:

Make fine adjustment of the value on the basis of manufacturer value if the manufacturer setting value can not meet the needs of practical application. Be cautious that amplitude of adjustment each time should not be too large.

In the event of weak loading capacity or slow rising of rotary speed, please increase the value of KP first under the precondition of ensuring no oscillation. If it is stable, please increase the value of KI properly to speed up response.

In the event of oscillation of current or rotary speed, decrease KP and KI properly.

Note: Improper setting of KP and KI may result in violent oscillation of the system, or even failure of normal operation. Please set them carefully.

F819 Slip coefficient	Setting range: 50~200	Mfr's value: 100
F820 Filtering coefficient of speed loop	Setting range: 0~100	Mfr's value: 0

F819 is used to adjust steady speed precision of motor in vector control.

In vector control mode, if speed fluctuation is higher or inverter stops instability, please increase the value of F820 properly; it will influence response speed of speed loop.

F821 Over Excitation Gain	Setting range: 0.0~100.0	Mfr's value: 0.0
---------------------------	--------------------------	------------------

Over excitation gain could help to limit the boosting DC bus voltage during deceleration.

The higher the value of F821 is, the better the limit effect is. But, if the value is too high, it will also occur high output current.

F822 Upper limit of speed control torque	Setting range:0.0~250.0	Mfr's value: 200
--	-------------------------	------------------

The parameter of F822 limits the output current in the vector control mode.

F823 Current-loop Proportion Coefficient	Setting range: 0.1~10.0	Mfr's value: 1.0
F825 Current-loop Integral Coefficient	Setting range: 0.1~10.0	Mfr's value: 1.0

F823 and F825 is to set the response time of current loop. The higher the value is, the faster the response is.

F836 Fast Current Limited	Setting range: 0: Invalid 1: Valid	Subject to inverter model
---------------------------	------------------------------------	---------------------------

The fast current limiting function can effectively protect the inverter from overcurrent faults. When the current is high, it will enter the fast current limiting state, and the motor sound will change. If it is in the current limiting state for a long time, it will display the fast current limiting fault code (FCL).

F838 SVC Control Mode	Setting range: 1: Control mode 1 2: Control mode 2 3: Control mode 3 4: Control mode 4	Mfr's value: 3
-----------------------	--	----------------

F839 Flux-weakening Coefficient	Setting range: 0.10~2.00	Mfr's value: 1.00
---------------------------------	--------------------------	-------------------

When induction motor is under flux-weakening control, F839 is to adjust the motor's flux-weakening curve. The smaller the value is, the lighter the depth of flux weakening is, and vice versa.

F840 Halt speed detection	Setting range: 0: based on feedback speed 1: based on given speed	Mfr's value: 0
---------------------------	---	----------------

F840=0: Inverter tests feedback speed when deceleration and stop output when meeting requirement.

F840=1: Inverter tests given speed when deceleration and stop output when meeting requirement.

F866 Static Position Identification	Setting range: 0: Invalid 1: Valid 2: Valid for the first-time running	Mfr's value: 2
F867 Position Identification Current	Setting range: 0~100	Mfr's value: 50
F868 Position Identification Frequency	Setting range: 500~16000	Mfr's value: 16000

F868: during position identification process, F868 is the frequency of output high-frequency voltage.

Note: F866~F868 is only for synchronous motor.

F870 PMSM back electromotive force (mV/rpm)	Setting range: 0.1~6553.0 (valid value between lines)	Mfr's value: 100.0
F871 PMSM D-axis inductance (mH)	Setting range: 0.01~655.30	Mfr's value: 5.00

F872	PMSM Q-axis inductance (mH)	Setting range: 0.01 ~ 655.30	Mfr's value: 7.00
F873	PMSM stator resistance (Ω)	Setting range: 0.001 ~ 65.535 (phase resistor)	Mfr's value: 0.500

·F870(back electromotive force of PMSM, unit = 0.1mV/1rpm, it is back electromotive force value between lines), it is forbidden to revert to Mfr's value by F160.

·F871(PMSM D-axis inductance, unit = 0.01 mH), it is forbidden to revert to Mfr's value by F160.

·F872(PMSM Q-axis inductance, unit = 0.01 mH), it is forbidden to revert to Mfr's value by F160.

·F873(PMSM Stator resistance, unit = m-ohm, 0.001 ohm), it is forbidden to revert to Mfr's value by F160.

·F870-F873 are motor parameters of PMSM, they are not shown in the motor nameplate. User can get them by auto tuning or asking manufacture.

F875	Compensation of Position Identification	Setting range: 0 ~ 1000	Mfr's value: 0
------	---	-------------------------	----------------

·F875 is to compensate the position identification in order to identify the rotor position precisely.

F876	PMSM injection current without load (%)	Setting range: 0.0 ~ 100.0	Mfr's value: 30.0
F878	PMSM cut-off point of injection current compensation without load (%)	Setting range: 0.0 ~ 50.0	Mfr's value: 10.0
F879	PMSM injection current with heavy load (%)	Setting range: 0.0 ~ 100.0	Mfr's value: 0.0

F876 and F879 are the percent of motor's rated current. F878 is the percent of motor's rated frequency.

For example:

When F876=30, if F877=10 and F878=0, the injection current without load is 20% of rated current.

If F876=30 and F878=10, when the running frequency is lower than 10%(F878), the injection current without load will always be 30%(F876). When the running frequency is higher than 10%(F878), the injection current without load will gradually be decreased. When the running frequency is higher than 20% (2 times of F878), the injection current will be 0.

F880	PMSM PCE detection time (S)	Setting range: 0.1 ~ 10.0	Mfr's value: 1.0
------	-----------------------------	---------------------------	------------------

F898	Power consumption correction coefficient	Setting range: 50.0 ~ 100.0	Mfr's value: 80.0
F899	Power consumption clear	Setting range: 0: invalid 1: Valid	Mfr's value: 0

When F899=1, accumulative power consumption will be clear. The value of function code will turn to 0 automatically.

5.10 Communication Parameter

F900 Communication Address	Setting range: 1~255: single inverter address 0: broadcast address	Mfr's value: 1
F901 Communication Mode	Setting range: 1: ASCII 2: RTU	Mfr's value: 2
F902 Stop bits	Setting range: 1~2	Mfr's value: 2
F903 Parity Check	Setting range: 0: Invalid 1: Odd 2: Even	Mfr's value: 0
F904 Baud Rate	Setting range: 0: 1200; 1: 2400; 2: 4800; 3: 9600; 4: 19200 5: 38400 6: 57600 7:115200	Mfr's value: 3
F905 Communication timeout period (S)	Setting range: 0.0~3000.0	Mfr's value: 0.0
F907 Time 2 of communication timeout (S)	Setting range: 0.0~3000.0	Mfr's value: 0.0

F904=9600 is recommended for baud rate, which makes run steady. Communication parameters refer to Appendix 4.

When F905 is set to 0.0, the function is invalid. When $F905 \neq 0.0$, if the inverter has not received effective command from PC/PLC during the time set by F905, inverter will trip into CE.

When $F907 > 0$, and receiving the previous data, if after the time set by F907, the next data is not received, inverter will output communication timeout signal. The timeout signal will be cleared by this terminal, and after receiving correct data, inverter will accumulate time again.

F926 CAN baud rate (kbps)	Setting range: 0: 20 1:50 2:100 3:125 4:250 5:500 6:1000	Mfr's value: 6
---------------------------	--	----------------

F928 BACnet address	Setting range: 0~127	Mfr's value: 1
---------------------	----------------------	----------------

F929 BACnet baud rate (Kbps)	Setting range: 9.6\19.2\38.4\57.6\76.8\115.0	Mfr's value: 9.6
------------------------------	---	------------------

F933 BACnet device No.	Setting range: 0~65535	Mfr's value: 1
F962 BACnet high byte of device No.	Setting range: 0~63	Mfr's value: 0

F962 and F933 together constitute the device number of BACnet. F933 is lower 16 bits.

F930 Keypad disconnected protection	0: Invalid 1~10	Mfr's value: 0
-------------------------------------	-----------------	----------------

F930 means that the delay time(s) that running inverter freely stops and jump to malfunction when taking out the keypad.

F950 Address 1 Read by Modbus communication	setting range: 0~0xFFFF	Mfr's value: 0x1000
F951 Address 2 Read by Modbus communication	setting range: 0~0xFFFF	Mfr's value: 0x1001
F952 Address3 Read by Modbus communication	setting range: 0~0xFFFF	Mfr's value: 0x1002

F953	Address 4 Read by Modbus communication	setting range: 0~0xFFFF	Mfr's value: 0x1003
F954	Address 5 Read by Modbus communication	setting range: 0~0xFFFF	Mfr's value: 0x1004
F955	Address 6 Read by Modbus communication	setting range: 0~0xFFFF	Mfr's value: 0x1005
F956	Address 7 Read by Modbus communication	setting range: 0~0xFFFF	Mfr's value: 0x1006
F957	Address8 Read by Modbus communication	setting range: 0~0xFFFF	Mfr's value: 0x1007
F958	Address 9 Read by Modbus communication	setting range: 0~0xFFFF	Mfr's value: 0x1008
F959	Address 10 Read by Modbus communication	setting range: 0~0xFFFF	Mfr's value: 0x1009

·F950~F959 could read the data in time. The corresponding value will be stored in 0x1400~0x1409.

·For example, if customer want to read F106\F113\F203\F208\H001, they can set 0x106\0x10D\0x203\0x208\0x4301 to F950-954. 0x1400 could be the starting address, and read five data as follows.

No.	0	1	2	3	4	5	6	7
Code	01	03	14	00	00	05	80	39
Description	Address	Read command	Read high-order address	Read low-order address	Read high-order digit	Read low-order digit	Low-order CRC	High-order CRC

F960	CAN Master-slave proportional control	setting range: 0:Invalid 1: Valid	Mfr's value: 0
------	---------------------------------------	-----------------------------------	----------------

·When F960=1, one of the drive is the host, and the other drives are the slaves. The master and slave are connected through CAN communication. The host sends the local speed ratio (current running frequency/F111) to the slave, and the slave multiplies the received speed ratio by F111 to obtain the target frequency of the host. The slave follows the host to run and stop.,

·Note:

F901 of all master-slave drives needs to be set to different values from 1-14.

Under stopping status, the no fault drive with the smallest address is the host. During operation, if the host disconnects, the slave with the smallest address changes to the host, and the system continues to run.

The host can be set to other speed control methods other than PID speed control.

5.11 PID Parameters

5.11.1 Internal PID adjusting and constant pressure water supply

Internal PID adjusting control is used for single pump or double pump automatic constant-pressure water supply, or used for simple close-loop system with convenient operation.

The usage of pressure meter:

As FAO2=1: channel A11

“10V” connect with the power supply of pressure meter, if the power supply of pressure meter is 5V, please supply a 5V power.

“A11” connect with the pressure signal port of pressure meter

“GND” connect with the grounding of pressure meter

As FAO2=2: channel A12

“10V” connect with the power supply of pressure meter, if the power supply of pressure meter is 5V, please supply a 5V power.

“A12” connect with the pressure signal port of pressure meter

“GND” connect with the grounding of pressure meter

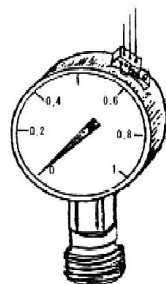

5.11.2 Parameters

FA00 Water supply mode	Setting range: 0: Single pump (PID control mode) 1: Fixed mode 2: Timing interchanging 5: Dormancy interchanging 6: fixed pumps interchanging by time 7: fixed pumps interchanging at sleep 10: master/slave fixed mode 11: master/slave interchanging by time 12:master/slave interchanging at sleep	Mfr's value: 0
------------------------	--	----------------

When FA00=0 and single pump mode is selected, the inverter only controls one pump. The control mode can be used in the closed-loop control system, for example, pressure, flow.

When FA00=1, one motor is connected with converter pump all the time, 1~3 pcs motors are connected to general pumps.

When FA00=2, three pumps are interchanging to connect with inverter for a fixed period of time. The duration time is set by FA25.

When FA00=5, inverter pumps enters into dormancy status, inverter pumps will convert to fixed pump, fixed pump will convert to inverter pump.

When FA00=6, one pump is always the inverter pump all the time, 1~3 pcs fixed pump will interchange the sequence according to the time of FA25.

When FA00=7, one pump is always the inverter pump all the time. When inverter pump is in sleeping mode, the 1-3pcs fixed pump will interchange the sequence.

When FA00=10, the inverter of the smallest address will be the master.

When FA00=11, when the master runs for the time of FA25, the next inverter will be the new master.

When FA00=12, when the master is in sleeping mode, the next inverter will be the new master.

FA01 PID adjusting target given source	Setting range: 0: FA04 1: AI1 2: AI2 4: FI (pulse frequency input)	Mfr's value: 0
--	--	----------------

When FA01=0, PID adjusting target is given by FA04 or MODBUS.

When FA01=1, PID adjusting target is given by external analog AI1.

When FA01=2, PID adjusting target is given by external analog AI2.

When FA01=4, PID adjusting target is given by FI pulse frequency (DI1 terminal).

When FA00=10, 11, 12, only FA01=0 is workable

FA02 PID Adjusting Feedback Given Source	Setting range: 1: AI1 2: AI2 3: FI (pulse frequency input) 4: Modbus given 5: Running current 6: Output power 7: Output torque 8: AI1-AI2 9: AI1+AI2 10: Max(AI1, AI2) 11. Min(AI1, AI2)	Mfr's value: 1
--	--	----------------

When FA02=1, PID feedback signal is given by external analog AI1.

When FA02=2, PID feedback signal is given by external analog AI2.

When FA02=3, PID feedback signal is given by FI pulse frequency input.

When FA02=4, PID feedback is given by Modbus. The Modbus address is 2030H, the given range is

0~1000.00, i.e., 0~100.0%.

When FA02=5, PID feedback signal is given by inverter running current.

When FA02=6, PID feedback signal is given by output power.

When FA02=7, PID feedback signal is given by output torque.

When FA02=8, PID feedback signal is given by the difference of AI1-AI2.

When FA02=9, PID feedback signal is given by the sum value of AI1+AI2.

When FA02=10, PID feedback signal is given by the Max value between AI1 and AI2.

When FA02=11, PID feedback signal is given by the Min value between AI1 and AI2.

FA03 Max limit of PID adjusting (%)	FA04~FA50	Mfr's value: 100.0
FA04 Internal PID pressure setpoint (%)	FA05~FA03	Mfr's value: 50.0
FA05 Min limit of PID adjusting (%)	0.0~FA04	Mfr's value: 0.0

FA03: When negative feedback adjusting is valid, if the feedback is higher than max limit of PID adjusting(FA03), pressure protection will occur. Then it will free stop, and "nP" is displayed. When positive feedback adjusting is valid, if feedback is higher than internal PID setpoint+PID dead zone(FA04+FA29), it indicates that feedback pressure is too low, inverter should accelerate or one more pump should be added.

FA04: When FA01=0, the value set by FA04 is digital PID setpoint. When the 4-line LCD display is display PID setpoint, customer can push UP/DOWN key to change it, and store it into FA04.

FA05: When negative feedback adjusting, if the feedback is lower than PID setpoint-PID dead zone(FA04-FA29), it indicates that feedback pressure is too low, inverter should accelerate or one more pump will be added. When positive feedback adjusting is valid, if the feedback is lower than min limit of PID adjusting, pressure protection will occur. Then it will free stop, and "nP" is displayed.

For example: if the range of pressure meter is 0-1.6MPa, the FA04 setpoint is $1.6*70\%=1.12\text{MPa}$, and the FA03 max limit pressure is $1.6*90\%=1.44\text{MPa}$, and the FA05 min limit pressure is $1.6*5\%=0.08\text{MPa}$.

FA06 PID polarity	0: Positive feedback 1: Negative feedback	Mfr's value: 1
-------------------	--	----------------

When FA06=0, the higher feedback value is, the higher the motor speed is. This is positive feedback.

When FA06=1, the lower the feedback value is, the higher the motor speed is. This is negative feedback.

FA07 Sleep mode	Setting range: 0: Valid 1: Invalid	Mfr's value: 1
-----------------	------------------------------------	----------------

When FA07=0, if inverter runs at the min frequency FA09 for a period time set by FA10, inverter will stop.

When FA07=1, the dormancy function is invalid.

FA09 PID Min frequency (Hz)	Setting range: MAX (F112, 0.1)~F111	Mfr's value: 5.00
-----------------------------	--	-------------------

The min frequency is set by FA09 when PID adjusting is valid.

FA10 Sleep delay time (S)	Setting range: 0~500.0	Mfr's value: 15.0
---------------------------	------------------------	-------------------

When FA07=0, inverter runs at the min frequency FA09 for a period time set by FA10, inverter will free stop and enter into the sleep status, "SLP" is displayed.

In single pump mode, if it is PID control of emptying port, it will display "SLP". If it is PID control of filling port, it will display "SLP1".

FA11 Wake delay time (S)	Setting range: 0.0~3000	Mfr's value: 3.0
--------------------------	-------------------------	------------------

When pressure protection(nP, nP1) or sleep mode(SLP, SLP1) is enable, after the wake delay time, if the pressure is lower than PID min limit (Negative feedback) or the pressure is higher than the PID max limit, inverter will begin running immediately. Otherwise, inverter will keep in sleep mode.

FA12 PID max frequency(Hz)	Setting range: FA09~F111	Mfr's value: 50.00
----------------------------	--------------------------	--------------------

When PID is valid, FA12 is the max frequency setpoint

FA13 pressure setpoint source of filling inlet	Setting range: 0: invalid 1: AI1 2: AI2	Mfr's value: 0
--	---	----------------

- FA13=0, PID control at filling inlet is invalid
- FA13=1, pressure setpoint source of filling inlet is AI1.
- FA13=2, pressure setpoint source of filling inlet is Ai2.

FA18 Whether PID adjusting setpoint is changable	0: Invalid 1: Valid	Mfr's value: 1
--	---------------------	----------------

When FA18=0 and FA01≠0, PID setpoint is the setting of the first time after power on. It can not be changed anymore.

FA19 Proportion Gain P	Setting range: 0.00~10.00	Mfr's value: 0.30
FA20 Integration time I (S)	Setting range: 0.1~100.0	Mfr's value: 0.3
FA21 Differential time D (S)	Setting range: 0.1~10.0	Mfr's value: 0.0
FA22 PID sampling period (2mS)	Setting range: 1~500	Mfr's value: 5

Increasing proportion gain, decreasing integration time and increasing differential time can increase the dynamic response of PID closed-loop system. However, if P is too high, I is too low or D is too high, system will not be steady.

Recommend adjusting method:

If mfr's value cannot satisfy requirement, fine adjustments can be proceed based on the mfr's value: increase the proportion gain firstly to ensure system not shaking; then reducing integration time to make system have fast response characteristics; if still not meet the requirement, increase differential time to make system overshoot. To avoid system oscillation, setting high value is not recommended.

FA22 works as PID adjustor sampling period, which means that the sampling time to feedback value for PID adjustor. The shorter the sampling time is, the faster adjustment speed is. Its basic unit is 2ms. E.g. 1 means sampling period is 2ms; 5 means 10ms.

The following is PID adjusting arithmetic

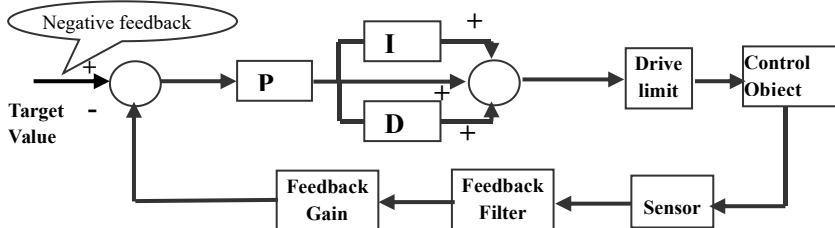

FA23 PID negative frequency output selection	Setting range: 0: Invalid 1: Valid 2: Only negative output	Mfr's value: 0
--	---	----------------

When FA23=0, PID output frequency is FA09~FA12.

When FA23=1, PID output frequency is -FA12~FA12.

When FA23=2, PID output frequency is -FA12~0.

FA23=1/2 is only valid when FA00=0.

FA24 Timing unit for pump switchover	Setting range: 0: hour 1: minute	Mfr's value: 0
FA25 Switchover Timing Setting	Setting range: 1~9999	Mfr's value: 100

Switching time is set by FA25. The unit is set by FA24.

FA26 Under-load protection mode	Setting Range 0: No protection 1: Protection by terminal input	Mfr's value: 0
---------------------------------	--	----------------

	2: Protection by PID 3: Protection by current	
FA27 Current threshold of under-load protection (%)	Setting range: 10~150	Mfr's value: 80
FA65 Signal Selection for Protection by Contactor	Setting Range 0: With and lack water 1: With water 2: Lack water 3: Protection by current	Mfr's value: 0
FA66 Duration time of under-load protection (S)	Setting range: 0~60	Mfr's value: 20

Note: the percent of under-load protection current corresponds to motor rated current.

Under-load protection is used to save energy. For some pumps device, when the output power is too low, the efficiency will get worse, so we suggest that the pumps should be closed.

During the running process, if the load decreases to zero suddenly, it means the mechanical part is broken. For example, belt is broken or water pump is dried up. Under-load protection must occur.

When FA26=1, water signal and lack water signal is controlled by two input terminals. When the lack water terminal is valid, inverter will enter into the protection status, and EP is displayed. When the water terminal is valid for a certain period(FA28), inverter will deactivate EP fault automatically.

When FA26=2, PID adjusting frequency runs to max frequency, if inverter current is lower than the product of FA27 value and rated current, inverter will enter PID under-load protection status immediately, and EP2 is displayed.

When FA26=3, if inverter current is lower than the product of FA27 and rated current, after duration time of FA66, inverter will enter under-load protection, and EP3 is displayed.

FA28 Waking time after under-load protection (min)	1~3000	Mfr's value: 60
--	--------	-----------------

After the duration time of FA28, inverter will judge that whether the under-load protection signal disappears.

If malfunction is reset, inverter will run again. Or else inverter will wait until malfunction resets. User can reset the inverter by pressing "stop/reset", inverter will stop.

FA29 PID dead zone (%)	0.0~10.0	Mfr's value: 2.0
FA30 Running Interval of restarting inverter pump (S)	2.0~999.9	Mfr's value: 20.0
FA31 Delay time of switch on pumps (S)	0.1~999.9	Mfr's value: 30.0
FA32 Delay time of switch off pumps (S)	0.1~999.9	Mfr's value: 30.0

FA29, PID dead zone has two functions. First, setting dead time can restrain PID adjustor oscillation. The greater this value is, the lighter PID oscillation is. But if the value of FA29 is too high, PID adjusting precision will decrease. For example: when FA29=2.0% and FA04=70, PID adjusting will be active during the feedback value from 68 to 72.

Second, FA29 is set to PID dead time when starting and stopping fixed pumps. When negative feedback adjusting is valid, if feedback value is lower than value FA04-FA29 (which equal to set value MINUS dead-time value), inverter will delay the set time of FA31, and then start the fixed pump. If feedback value is higher than value FA04+FA29 (which equal to set value PLUS dead-time value), inverter will delay the set time of FA32, then stop the fixed pump.

When the fixed pump will be switched on, the inverter pump will free stop. After the fixed pump is fully started, inverter will delay the time of FA30, and restart inverter pump. Or, when rotation time(FA25) is finished, the fixed pump will free stop. After the delay time of FA30, inverter will restart the inverter pump.

When inverter drives 1 inverter pump and 1 fixed with negative feedback adjusting, if the frequency of inverter pump already reaches the max value and after the delay time (FA31), the pressure is still lower than the setpoint to switchover the fixed pump, then the inverter will stop output immediately and motor will freely stop. At the same time, the fixed pump will be started. After the fixed pump is fully run, if the present pressure is higher than the setpoint, inverter will low down the output to the min frequency. After delaying the set time (FA32),

inverter will stop the fixed pump and the inverter pump will work with PID control.

When inverter drives 1 inverter pump and 1 fixed with positive feedback adjusting, if the frequency of inverter pump already reaches the max value and after the delay time (FA31), the pressure value still higher than the setpoint to switchover the fixed pump, then the inverter will stop output immediately and motor will freely stop. At the same time the general pump will be started. After the general pump runs, if the present pressure is lower than the setpoint, inverter will low down the output to the min frequency. After delaying the set time (FA32), inverter will stop the fixed pump and the inverter pump will work with PID control.

FA33 stop mode when constant pressure water supply	0: free stop 1: deceleration to stop	Mfr's value: 0
--	---	----------------

FA33 is used to set the stop mode after inverter stops converter pump or trips with nP and EP.

FA34 pressure measurement unit	0: % 1: Mpa 2: bar 3: psi 4: CM 5: M 6: CM/Seg 7: M/Seg 8: °C 9: pa 10: mb	Mfr's value: 0
--------------------------------	--	----------------

FA36 No.1 relay is available	0: not available 1: available	Mfr's value: 0
FA37 No.2 relay is available	0: not available 1: available	Mfr's value: 0

No. 1 relay corresponds to the terminal DO1, No. 2 relay corresponds to the terminal TA1/TC1.

FA38 Proportion gain Kp2	Setting range: 0.00~10.00	Mfr's value: 0.30
FA39 Integration time Ki2(S)	Setting range: 0.1~100.0	Mfr's value: 0.3
FA40 Differential time Kd2(S)	Setting range: 0.0~10.0	Mfr's value: 0.0
FA41 PI parameter switchover type	Setting range: 0: no switchover 1: reserved 2: Auto switchover 3: reserved	Mfr's value: 0
FA42 Switchover error 1	Setting range: FA05~FA43	Mfr's value: 0.0
FA43 Switchover error 2	Setting range: FA42~FA03	Mfr's value: 0.0

·FA38~FA40 is the second group of PID parameters. They can be used with the first group parameters separately.

·When FA41=0, the first group PID parameters are used. The parameters are FA19~FA21.

·When FA41=2, if the current error(difference between PID given value and PID feedback) is higher than FA43, the second group of PID parameters will be used. When the current error is lower than FA42, the first group of PID parameters will be used. When current error is between error 1 and error 2, PID will

use transition parameters.

FA44 Master/slave control mode	0:same frequency 1: high efficiency mode	Mfr's value: 0
--------------------------------	---	----------------

- When FA44=0, under master/slave control, all inverters run at the same speed.
- When FA44=1, under master/slave control,each pump switched on will run to max frequency one by one, but the last one will run with PID control.

FA45 pressure setpoint compensation (%)	Setting range: 0.0~10.0	Mfr's value: 0
---	-------------------------	----------------

- PID given value(FA01) plus FA45 will be the final PID given value.

FA47 The sequence of starting No. 1 relay	Setting range: 1~20	Mfr's value: 20
FA48 The sequence of starting No. 2 relay	Setting range: 1~20	Mfr's value: 20

The sequence of starting relays is set by FA47~FA48. The default value is 20, and 20 means invalid. The setting value of FA47 and FA48 must be different with each other, and one of them must be set to 1. Otherwise "Err5" is displayed in the keypad.

FA49 filling inlet pressure range(%)	Setting range: 0.0~100.0	Mfr's value: 100.0
--------------------------------------	--------------------------	--------------------

- FA49 is used to set the pressure range of filling input.

FA50 Empty outlet pressure range(%)	Setting Range: 0.0~100.0	Mfr's value: 100.0
-------------------------------------	--------------------------	--------------------

- FA50 is used to set the pressure range of empty outlet.

FA51 pressure threshold of refilling at inlet (%)	Setting range: FA52~FA49	Mfr's value: 0.1
FA52 Pressure threshold of water-lack at inlet(%)	Setting range: 0.0~FA51; 0.0: invalid	Mfr's value: 0.0
FA53 delay time for refilling at inlet(S)	Setting range: 0.0~60.0	Mfr's value: 0.0
FA54 delay time for warning water-lack(S)	Setting range: 0.0~60.0	Mfr's value: 0.0

- FA52: It is the pressure to indicate that it is the lack of water at inlet. When FA52=0.00, the function of detecting negative pressure is invalid.

·The function of detecting negative pressure: The pressure at inlet is detected in real time. If the pressure at inlet is lower than FA52, after the delay time of FA54, all inverter will free stop and alarm with "EP5". When the pressure at inlet is higher than FA51, after the delay time of FA53, "EP5" will be reset and all pump will rework.

Note:

1. This function will only work if there is negative-pressure detecting device at inlet. If not, FA52 should be set to 0.0.
2. FA13 is the given source of inlet pressure. It can not be the same source of PID feedback(FA02). FA02 is the feedback source of outlet.

FA55 master/slave pump number	Setting range: 0~14	Mfr's value: 0
-------------------------------	---------------------	----------------

- When it is master/slave control, if there is any mistake of setting, the inverter will display the following alarm.

·E001: If two inverter has the same address, the inverter will alarm with"E001"

·E002: If FA55≠0, but the actual inverter number is less than FA55, the master inverter will alarm with

“E002”.

·E003: If CAN communication is interfered, the inverter will alarm with “E003”.

·E004: If FA55≠0, but the actual inverter number is more than FA55, the master inverter will alarm with “E004”

FA56 outlet sensor disconnection protection	0: invalid 1: valid	Mfr's value: 0
FA57 inlet sensor disconnection protection	0: invalid 1: valid	Mfr's value: 0

·When it is master/slave control, the setting of F400 and F406 is higher than 0.10.

If all outlet emptying sensors are disconnected and FA56=1, the inverter will alarm with AEr0(fault number 58)

If all inlet filling sensors are disconnected and FA57=1, the inverter will alarm with AEr1(fault number 73)

FA58 Fire pressure given value (%)	Setting range: 0.0~100.0	Mfr's value: 80.0
------------------------------------	--------------------------	-------------------

FA58 is also called second pressure, when the fire control terminal is valid or switchover terminal of fire mode at PID control is valid, pressure target value will switch into second pressure value.

FA59 Emergency fire mode	Setting range: 0: Invalid 1: Emergency fire mode 1 2: Emergency fire mode 2	Mfr's value: 0
--------------------------	---	----------------

When emergency fire mode is valid and emergency fire terminal is valid, inverter will be forbidden operating and protecting (When OC and OE protection occur, inverter will reset automatically and start running). And inverter will run at the frequency of FA60 or target frequency until inverter is broken.

Emergency fire mode 1: when the terminal is valid, inverter will run at target frequency.

Emergency fire mode 2: when the terminal is valid, inverter will run at the frequency of FA60.

FA60 Running frequency of emergency fire	Setting range: F112~F111	Mfr's value: 50.0
--	--------------------------	-------------------

When emergency fire mode 2 is set, the fire terminal is valid, inverter will run at the frequency set by FA60.

FA62 Fire mode stop	Setting range: 0: no stop 1: manual stop valid	Mfr's value: 0
---------------------	--	----------------

·When FA62=0, inverter keeps working at fire emergency mode

·When FA62=1, inverter quits from fire emergency mode.

FA67 Wakeup mode	Setting range: 0: wakeup mode 1 1: wakeup mode 2	Mfr's value: 0
FA68 Wakup pressure of postive feedback(%)	Setting range: 0.0~100.0	Mfr's value: 30.0
FA69 Wakup pressure of negative feedback (%)	Setting range: 0.0~100.0	Mfr's value: 30.0

·When FA67=0, inverter will be awoken according to FA03 and FA05.

If FA67=1 and FA06=1, when the present pressure is higher than target pressure, and PID adjusts to min frequency, inverter will enter into sleeping status after the delay time of FA10. If inverter is in the sleeping status and the present pressure is lower than target pressure-FA69, inverter will be awoken after wake delay time (FA11) .

If FA06=0, when the present pressure is lower than target pressure, and PID adjusts to min frequency, inverter will free stop and enter into sleeping status after the setting time of FA10. If inverter is in the sleeping status, when the present pressure is higher than target pressure + FA68, inverter will be awoken after wake delay time(FA11).

If target pressure+FA68> 100%,it is equal to 100%. If target pressure-FA69 <0%, it is equal to 0%.

FA78 Flow detection enable	Setting range: 0: invalid 1: valid	Mfr's value: 0
FA79 interval time for flow detection	Setting range: 1~60000	Mfr's value: 60

(min)		
FA80 pressure compensation for flow detection(%)	Setting range: 0.1~10.0	Mfr's value: 2.0
FA81 no flow restart delay (S)	Setting range: 0.0~3000.0	Mfr's value:10.0

When FA78=1, no-flow detection is enable in order to prevent motor to be damaged in case of no flow. When the pressure in pipe is stable, after the interval time of FA79, the target pressure will be change to "present pressure + pressure compensation(FA80)". When the pressure in pipe becomes stable again, after FA81 delay time, the target pressure will be recovered to previous setpoint.

FA82 No.3 relay is available	0: not available 1: available	Mfr's value: 0
FA83 The sequence of starting No. 3 relay	Setting range: 1~20	Mfr's value: 20

·No. 3 relay is TA2/TC2

FA84 Sleep mode	0: sleeping mode 1 1: sleeping mode 2	Mfr's value: 0
-----------------	--	----------------

·When FA84=0, if the present pressure is higher than the target pressure, slave will decrease to PID min frequency(FA09) . After sleep delay time(FA10), the slave will be in sleep status

When FA84=1, if the present pressure is higher than target pressure, the slave will decrease to PID min frequency(FA09). After a half of sleep delay time(FA10), the slave will decrease again to inverter's min frequency(F112). After the second half of FA10, the slave will be in sleep status.

FA85 Dead Zone mode	0: \pm dead zone 1: + dead zone	Mfr's value: 0
---------------------	--------------------------------------	----------------

·When FA85=0, PID control is in the range of target pressure \pm dead zone.

·When FA85=1, PID control is in the range of target pressure + dead zone.

FA86 Internal PID pressure setpoint 2(%)	Setting range: FA05~FA03	Mfr's value: 50.0
FA87 Internal PID pressure setpoint 3(%)	Setting range: FA05~FA03	Mfr's value: 50.0
FA88 Internal PID pressure setpoint 4(%)	Setting range: FA05~FA03	Mfr's value: 50.0

·FA86~FA88 is more option for target pressure. Customers can use the function combination of DI terminal(F316~F321=44 , 45). Please refer to Table 5-4 outlet target pressure selection.

FA89 pump start counter		
-------------------------	--	--

·It counts each time of starting pump, including sleep/awake operation.

FA90 Switchover of inlet/outlet PID control	0: invalid 1: valid	Mfr's value: 0
FA91 Inlet max pressure(%)	setting range: FA93~FA49	Mfr's value: 25.0
FA92 Pressure of switch to inlet PID control(%)	setting range: FA94~FA49	Mfr's value: 5.0
FA93 Inlet pressure setpoint(%)	setting range: FA94~FA91	Mfr's value: 10.0
FA94 Inlet min pressure(%)	setting range: 0.0~FA93	Mfr's value: 0.0
FA95 Inlet PID control polarity	setting range: 0: Positive 1: Negative	Mfr's value: 0

·When it is PID control of outlet, if the pressure at inlet is lower than FA93, inverter will switchover to inlet PID control according to inlet's pressure setpoint, max pressure, min pressure.

·When it is inlet PID control, if inlet pressure is higher than FA92, inverter will switchover to outlet PID control.

Note: When it is inlet PID control, if it is negative feedback, if the inlet pressure is higher than FA91, inverter will free stop and trip with “nP1”. If it is positive feedback, if the inlet pressure is lower than FA94, inverter will free stop and trip with “nP1”.

FA96 level control	setting range: 0: invalid 1: valid	Mfr's value: 0
--------------------	---------------------------------------	----------------

·When FA96=1, level control is enable.

When DI terminal is enable with 71(filling), if DI terminal is enable with 73(high entry level), inverter will stop. Otherwise, inverter will keep running.

When DI terminal is enable with 72(emptying), if DI terminal is enable with 74(low entry level), inverter will stop. Otherwise, inverter will keep running.

FA98 Inverter pump stop when a fixed pump is switched on	setting range: 0: invalid 1: valid	Mfr's value: 1
--	---------------------------------------	----------------

·At inverter/fixed pump mode(FA00=1/2/5), when fixed pump is switched on, inverter pump could stop or not stop.

·When FA98=0, inverter pump will not stop, usually the fixed pump is softly started at this situation.

·When FA98=1, inverter will stop during switching on fixed pump.

FA99 parameter synchronizing	setting range: 0: invalid 1: valid	Mfr's value: 0
------------------------------	---------------------------------------	----------------

·When it is master/slave control, if a new inverter is added in the pump group, it is only need to set F203, F900 and FA00. Then customer can set FA99=1 in any inverter in the pump group, then all the parameter setting will be copied to the new inverter. After that, FA99 will be changed to 0 automatically.

FB00 Pump autotuning	0: invalid 1: valid	Mfr's value: 0
FB01 Pump autotuning time step(S)	setting range: 0.1~5.0	Mfr's value: 1.0
FB02 Pump autotuning current(A)	setting range: 0.0~F803	Mfr's value: 0.0

·When FB00=1, after inverter run, it make autotunning of pump. After autotuning, PID min frequency(FA09) will be changed automatically. If the autotuning is not successful, inverter will alarm with “ErAT”.

FB10 Outlet pressure setpoint of manual control(%)	setting range: FB13~FB15	Mfr's value: 50.0
FB11 Outlet sleep frequency of manual control(Hz)	setting range: F112~F111	Mfr's value: 5.00
FB12 Outlet Sleep delay time of manual control (S)	setting range: 0.0~500.0	Mfr's value: 15.0
FB13 Outlet wakeup pressure setpoint of manual control(%)	setting range: 0.0~FB10	Mfr's value: 0.0
FB14 Outlet wakeup delay time of manual control(S)	setting range: 0.0~3000.0	Mfr's value: 3.0
FB15 Outlet max pressure of manual control(%)	setting range: FB10~FA50	Mfr's value: 100.0

·When DI terminal is valid of 46(Manual pressure selection), FB10~FB15 is the parameter for manual control of outlet.

FB16 Dry operation protection	setting range: 0: invalid 1: valid	Mfr's value: 0
FB17 Dry operation pressure (%)	setting range: 0.0~FB23	Mfr's value: 0.0
FB18 Dry operation delay time(S)	setting range: 0.0~300.0	Mfr's value: 60.0
FB19 Dry operation current(A)	setting range: 0.1~1000.0	Mfr's value: according to power ratings

·FB16=1, when inverter is in outlet PID control, after all pumps have been switched on, if the actual outlet pressure is lower than FB17* target pressure and the current is lower than FB19 as well, inverter will alarm with EP4 after delay time of FB18.

FB20 Pipe filling installation	setting range: 0: invalid 1: valid	Mfr's value: 0
FB21 Pipe filling frequency(Hz)	setting range: 0.00~FA12	Mfr's value: 5.00
FB22 Prefilling time (S)	setting range: 0.0~300.0	Mfr's value: 60.0
FB28 Filling timeout(min)	setting range: 1~3000	Mfr's value: 10.0

·When FB20=1, pipe filling installation is enable. It is only active the first time the pressure group is activated. The pressure feedback is never reached the target pressure ago. In general, this happens at the first time the pumping equipment is turned on and the pressure group is activated.

·When the inverter is started, if the pressure feedback is lower than target pressure, inverter will run at the max frequency. If it is master/slave control, all pump will be started. After running for FB22 time, the master inverter will decrease to FA09+FB21, and slave inverter will stop. When the pressure feedback reaches the target pressure, inverter will quit the pipe filling mode and execute normal PID control.

If the filling time exceeds FB28, inverter will stop and alarm with "FILL".

FB23 Leakage pressure detection(%)	setting range: FB17~80.0 0.0: invalid	Mfr's value: 0.0
FB24 Leakage detecting time 1(S)	setting range: 0.0~300.0	Mfr's value: 5.0
FB25 Leakage detecting time 2(S)	setting range: 0.0~300.0	Mfr's value: 5.0
FB26 Leakage detecting time 3(S)	setting range: 0.0~300.0	Mfr's value: 5.0
FB27 Leakage detecting cycle	setting range: 1~10	Mfr's value: 3

·When FB23=0.0, leakage detection is not enable.

Detection pressure is the percentage between the present outlet pressure and target pressure.

·When the inverter run at the max frequency and all pumps are started, if the present pressure is lower than leakage detection pressure for FB24 time, inverter will stop and execute leakage detection.

·Leakage detection procedure: inverter will start and run up to max frequency after delay time of FB25. If the present pressure is lower than leakage pressure setpoint, inverter will stop after running for FB26. Then, inverter will execute the same action again.

If the present pressure is higher than leakage pressure setpoint, inverter will quit the leakage detection mode.

If the detection operation is executed for more than FB27 times, inverter will stop and alarm with "EP6".

FB29 Activate Manual/Auto control	setting range: 0: invalid 1: valid	Mfr's value: 0
-----------------------------------	------------------------------------	----------------

·When FB29=1, manual/auto control is enable. And DI terminal also should be defined as 46 and 47.

FB31 Run time for cleaning(S)	setting range: 1~3000	Mfr's value: 30
FB32 Stop time for cleaning(S)	setting range: 1~3000	Mfr's value: 30

·In manual control, when the DI terminal defined as 75(pump cleaning) is enable, inverter starts to clean pump. It will run forward for FB31, stop for FB32, run backward for FB31, and stop for FB32. The running frequency is FA09.

FB33 Solar filtered time for frequency limit (S)	setting range: 0.0~100.0	Mfr's value: 3.0
--	--------------------------	------------------

·When FB35 is valid and FB33≠0, if the frequency limit is higher than min frequency, inverter will start after filtered time of FB33.

FB34	Solar mode enable	setting range: 0: invalid 1: valid	Mfr's value: 0
------	-------------------	------------------------------------	----------------

·When FB34=1, solar pump mode is enable, the undervoltage value will be adjusted automatically according to actual power ratings of inverter.

·Solar pump mode is only valid when F203=0 or F203=9.

·Under solar pump mode, output frequency is adjusted according to the sunlight and DC bus voltage.

FB35	Frequency limiting source	setting range: 0: invalid 1: AI1 2: AI2	Mfr's value: 0
------	---------------------------	--	----------------

·The actual PID output frequency will be always lower than frequency limit corresponding to analog input. When the frequency corresponding to analog input is lower than min frequency, inverter will stop.

·FB35=0, frequency limit for solar is not valid.

·FB35=1, output frequency is limited by AI1 input.

·FB35=2, output frequency is limited by AI2 input.

·When it is PID control(only FA00=0), if frequency limit corresponding to AI is lower than FA09, inverter will stop. When it is not PID control, if frequency limit corresponding to AI is lower than F112, inverter will stop.

FB36	Outlet feedback compensation direction	setting range: 0: positive 1: negative	Mfr's value: 0
FB37	Outlet feedback compensation display(%)	setting range: 0.0~FA50	Mfr's value: 0.0
FB38	Inlet feedback compensation direction	setting range: 0: positive 1: negative	Mfr's value: 0
FB39	Inlet feedback compensation display(%)	setting range: 0.0~FA49	Mfr's value: 0.0

·When FB36=0, the display of outlet pressure feedback is the actual feedback +FB37.

·When FB36=1, the display of outlet pressure feedback is the actual feedback -FB37.

·When FB38=0, the display of inlet pressure feedback is the actual feedback +FB39.

·When FB38=1, the display of inlet pressure feedback is the actual feedback -FB39.

FB40	Anti-freeze/Anti-rust function	setting range: 0: invalid 1: valid	Mfr's value: 0
FB41	Stop time for Anti-freeze/Anti-rust (S)	setting range: 1.0~3000.0	Mfr's value: 60.0
FB42	Run time for Anti-freeze/Anti-rust (S)	setting range: 1.0~3000.0	Mfr's value: 60.0

·When FB40=1, the sleeping master inverter will be waked up after stopping time of FB41. Then it will run for time of FB42. If it meets the sleeping condition, master inverter will recover to sleeping mode.

The standby slave inverter will run after stopping time of FB41. It will run for time of FB42, and then stop again. The running frequency is sleeping frequency.

Note: fixed pump is not available with this function.

FB43	Well pump mode	setting range: 0: invalid 1: valid	Mfr's value: 0
------	----------------	------------------------------------	----------------

·FB43 is to define the pump as well pump.

FB44	Anti-return valve installed	setting range: 0: invalid 1: valid	Mfr's value: 0
FB45	delay time for restart pump without anti-return valve(minute)	setting range: 0~99	Mfr's value: 3

·FB44 means whether there is anti-return valve in pump.

·When it is well pump mode or solar mode, if there is no anti-return value in pump system, it is necessary to wait until the end of discharging water column in outlet pipe. If FB44=0, when inverter is restarted from sleep mode or reset from alarm, inverter should delay for FB45 and then run.

FB46	Accelerating time for valid water supply(S)	setting range: 0.0~100.0	Mfr's value: 0.0
FB47	Decelerating time for valid water supply(S)	setting range: 0.0~100.0	Mfr's value: 0.0

·When FB46≠0, F203=9, if the running frequency is lower than FA09 during acceleration, then inverter will execute FB46 as accelerating time.

·When FB46≠0, F203=0, if the running frequency is lower than F112 during acceleration, then inverter will execute FB46 as accelerating time.

·When B47≠0, FA84=0, if the running frequency is lower than FA09 during deceleration, then inverter will execute FB47 as decelerating time.

·When B47≠0, FA84=1, if the running frequency is lower than FA112 during deceleration, then inverter will execute FB47 as decelerating time.

FB48	Anti-jam function	setting range: 0: invalid 1: valid	Mfr's value: 0
FB49	Jam current(%)	setting range: 100~150	Mfr's value: 115
FB50	Jam judgement time(S)	setting range: 0.1~60.0	Mfr's value: 10.0
FB51	Delay time for anti-jam running(S)	setting range: 0.0~30.0	Mfr's value: 3.0
FB52	Anti-jam running time(S)	setting range: 1.0~30.0	Mfr's value: 3.0
FB53	Number of times of anti-jam attempt	setting range: 1~10	Mfr's value: 3

·Anti-jam function is only valid when F203=0. Usually the application is waste water pump, and no pressure sensor is used.

·When FB48=1, if the current is higher than FB49 and last for FB50, inverter will start to judge whether the pump is blocked. The procedure is as follows.

Inverter will stop firstly, delay for FB51, and run backwards up to F113 and last for FB52. Then, inverter will stop again, delay for FB51, and run forwards up to F113 and last for FB52. If the present current is always lower than FB49 even after two times of FB52, inverter will quit the anti-jam judgement.

If the current is higher than FB49, then inverter will execute another circulation of anti-jump judgement. If the circulation exceeds FB53, inverter will stop and alarm with ErJA.

FB54	Max sunlight(W/m2)	setting range: FB55~1500	Mfr's value: 1500
FB55	Working sunlight(W/m2)	setting range: FB56~FB54	Mfr's value: 1000
FB56	Min sunlight(W/m2)	setting range: FB57~FB55	Mfr's value: 600
FB57	Alarm min sunlight(W/m2)	setting range: 0~FB56 0: invalid	Mfr's value: 0

·The max sunlight corresponds to analog 10V.

·When F203=0, analog input of working sunlight corresponds to F113, analog input of min sunlight corresponds to FA09.

·When F203=9, analog input of working sunlight corresponds to FA12, analog input of min sunlight corresponds to FA09.

·When solar mode is enable(FB34=1), if the present frequency is FA09 and run for FA10 time, inverter will enter into solar sleep mode, and display SSLP.

FB58	Open-circuit voltage of solar panel (V)	setting range: FB59~800	Mfr's value: T3:682 T2/S2:379
FB59	Max-power voltage of solar panel(V)	setting range: 100~FB58	Mfr's value: T3:556 T2/S2:309

·Set FB58 and FB59 according to the technical data of solar panel.

FB60	voltage regulation coefficient	setting range:0.01~10.00	Mfr's value:1.00
FB61	voltage regulation cycle	setting range:0.001~1.000	Mfr's value: 0.001

· FB60 and FB61 is used to regulate the DC bus voltage at solar mode.

FB80	Password for pump manu	setting range: 0~9999	Mfr's value: 0
------	------------------------	-----------------------	----------------

5.12 Torque control parameters

FC00	Speed/torque control selection	Setting range: 0: Speed control 1: Torque control 2: Terminal switchover	Mfr's value: 0
------	--------------------------------	---	----------------

0: speed control. Inverter will run by frequency setpoint, and output torque will automatically match with the torque of load, and output torque is limited by max torque (set by manufacturer.)

1: Torque control. Inverter will run by setting torque, and output speed will automatically match with the speed of load, and output speed is limited by max speed (set by FC23 and FC25). Please set the proper torque and speed limited.

2: Terminal switchover. User can set DIX terminal as torque/speed switchover terminal to realize switchover between torque and speed. When the terminal is valid, torque control is valid. When the terminal is invalid, speed control is valid.

FC02	Torque accel/decel time (S)	Range: 0.1~100.0	1.0
------	-----------------------------	------------------	-----

The time is for inverter to run from 0% to 100% of rated torque.

FC06	Torque given channel	Setting range: 0: Digital given (FC09) 1: Analog input AI1 2: Analog input AI2 4: Pulse input channel FI 5: Modbus given	0
------	----------------------	---	---

When FC06=4, only DI1 terminal can be selected because only DI1 terminal has the pulse input function.

FC07	Torque given coefficient	0~3.000	3.000
FC09	Torque given command value (%)	0~300.0	100.0

FC07: when input given torque reaches max value, FC07 is the ratio of inverter output torque and motor rated torque. For example, if FC06=1, F402=10.00, FC07=3.00, when AI1 channel output 10V, the output torque of inverter is 3 times of motor rated torque.

FC09 means the percentage relative to motor rated torque.

FC14	Offset torque given channel	Setting range: 0: Digital given (FC17) 1: Analog input AI1 2: Analog input AI2 4: Pulse input channel FI 5: Reserved	0
FC15	Offset torque coefficient	0~0.500	0.500
FC16	Offset torque cut-off frequency (%)	FC18~100.0	10.00
FC17	Offset torque command value (%)	0~50.0	10.00

· Offset torque is used to output larger start torque which equals to setting torque and offset torque when motor drives big inertia load. When actual speed is lower than the setting frequency by FC16, offset torque is given by FC14. When actual speed is higher than the setting frequency by FC16, offset torque is 0.

· When FC14≠0, and offset torque reaches max value, FC15 is the ratio of offset torque and motor rated torque. For example: if FC14=1, F402=10.00 and FC15=0.500, when AI1 channel outputs 10V, offset torque is 50% of motor rated torque.

FC18	Bias torque cut-off frequency 0(%)	Range: 0.1~FC16	0.0
------	------------------------------------	-----------------	-----

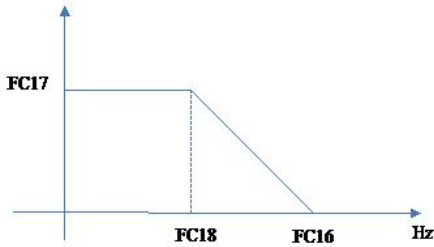

Fig 5-26 Diagram of torque bias compensation

In torque mode, when running frequency is less than FC18, the torque bias is set to the setpoint of FC17. When running frequency is between FC18 and FC16, it decays linearly. When running frequency is greater than FC16, the torque bias compensation is zero.

FC22	Forward speed limited channel	Setting range: 0: Digital given (FC23) 1: Analog input AI1 2: Analog input AI2 4: Pulse input channel FI 5: Reserved	0
FC23	Forward speed limited (%)	0~100.0	10.0
FC24	Reverse speed limited channel	0: Digital given (FC25) 1: Analog input AI1 2: Analog input AI2 4: Impulse input FI	0
FC25	Reverse speed limited (%)	0~100.0	10.0

·Speed limited FC23/FC25: if given speed reaches max value, they are used to set percent of inverter output frequency and max frequency F111.

FC28	Electric torque limit channel	0: Digital given (FC30) 1: Analog input AI1 2: Analog input AI2 4: Pulse input channel FI 5: Reserved	0
FC29	Electric torque limit coefficient	0~3.000	3.000
FC30	Electric torque limit (%)	0~300.0	200.0
FC33	Braking torque limit channel	0: Digital given (FC35) 1: Analog input AI1 2: Analog input AI2 4: Pulse input channel FI 5: Reserved	0
FC34	Braking torque limit coefficient	0~3.000	3.000
FC35	Braking torque limit (%)	0~300.0	200.00

·When motor is in the electric status, output torque limit channel is set by FC28. When FC28 does not equal to 0, limit torque is set by FC29. When FC28=0, limit torque is set by FC30.

·When motor is in the Braking status, Braking torque limit channel is set by FC31. When FC33 does not equal

to 0, limit torque is set by FC34. When FC33= 0, limit torque is set by FC35.

FC36 Lower Torque Limit Enabled	Setting range: 0: Invalid 1: Valid	Mfr's value: 0
FC37 Frequency for Lower Torque Limit	Setting range: 2.00~50.00	Mfr's value: 10.00
FC40 Threshold of Lower Torque Limit	Setting range: 0-20.0	Mfr's value: 3.0
FC41 Threshold of Lower Frequency Limit	Setting range: 1.00-10.00	Mfr's value: 1.00

FC38 Filtering Time (ms)	Setting range: 0-5000	Mfr's value: 500
--------------------------	-----------------------	------------------

When the given torque command is increased or the loading torque is decreased, it is the delay time for keeping accelerating.

FC39 Max Torque (%)	Setting range: 0.0-300.0	Mfr's value: 250
---------------------	--------------------------	------------------

FC48 Torque switchover enabled	Setting range: 0: Invalid 1: Valid	0
FC49 Current-limiting point 2 (%)	Setting range: F608~200	190
FC50 Frequency switchover point 1(Hz)	Setting range: 1.00~FC51	10.00
FC51 Frequency switchover point 2(Hz)	Setting range: FC51~F111	20.00

·FC48 is used to limit max torque or max current during running process. In VF and auto torque promotion mode, it is used to limit current, in vector control mode. It is used to limit torque.

·FC49 is the percentage of rated current in VF and auto torque promotion mode. FC49 is the percentage of rated torque in vector control mode.

·FC50 and FC51 is frequency switchover point when torque or current change. Please see below Fig.

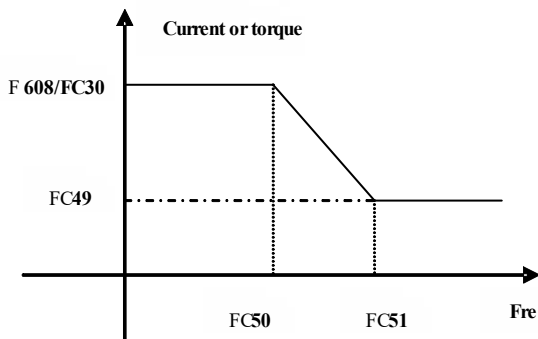

5.13 Time setting

FD00	Year	Setting range: 2000~9999	Mfr's value: local time
FD01	Month	Setting range: 1~12	Mfr's value: 5
FD02	Date	Setting range: 1~31	Mfr's value: 15
FD03	Week	Setting range: 1~7	Mfr's value: 1
FD04	Hour	Setting range: 0~23	Mfr's value: 8
FD05	Minute	Setting range: 0~59	Mfr's value: 0
FD06	Second	Setting range: 0~59	Mfr's value: 0

FD07	Supplying water on appointed date	Setting range: 0: invalid 1: valid	Mfr's value: 0
FD08	Supplying water on weekend	Setting range: 0: invalid 1: valid	Mfr's value: 0
FD09	Supplying water on workday	Setting range: 0: invalid 1: valid	Mfr's value: 0
FD10	Starting time 1 on appointed date	Setting range: 01.01~12.31	Mfr's value: 1.01
FD11	Stopping time 1 on appointed date	Setting range: 01.01~12.31	Mfr's value: 1.01
FD12	Pressure set-point 1 on appointed date	Setting range: FA05~FA03	Mfr's value: 0.0
FD13	Starting time 2 on appointed date	Setting range: 01.01~12.31	Mfr's value: 1.01
FD14	Stopping time 2 on appointed date	Setting range: 01.01~12.31	Mfr's value: 1.01
FD15	Pressure set-point 2 on appointed date	Setting range: FA05~FA03	Mfr's value: 0.0
FD16	Starting time 3 on appointed date	Setting range: 01.01~12.31	Mfr's value: 1.01
FD17	Stopping time 3 on appointed date	Setting range: 01.01~12.31	Mfr's value: 1.01
FD18	Pressure set-point 3 on appointed date	Setting range: FA05~FA03	Mfr's value: 0.0
FD19	Starting time 4 on appointed date	Setting range: 01.01~12.31	Mfr's value: 1.01
FD20	Stopping time 4 on appointed date	Setting range: 01.01~12.31	Mfr's value: 1.01
FD21	Pressure set-point 4 on appointed date	Setting range: FA05~FA03	Mfr's value: 0.0
FD22	Starting time 5 on appointed date	Setting range: 01.01~12.31	Mfr's value: 1.01
FD23	Stopping time 5 on appointed date	Setting range: 01.01~12.31	Mfr's value: 1.01
FD24	Pressure set-point 5 on appointed date	Setting range: FA05~FA03	Mfr's value: 0.0
FD25	Starting time 6 on appointed date	Setting range: 01.01~12.31	Mfr's value: 1.01

FD26	Stopping time 6 on appointed date	Setting range: 01.01~12.31	Mfr's value: 1.01
FD27	Pressure set-point 6 on appointed date	Setting range: FA05~FA03	Mfr's value: 0.0
FD28	Starting time 7 on appointed date	Setting range: 01.01~12.31	Mfr's value: 1.01
FD29	Stopping time 7 on appointed date	Setting range: 01.01~12.31	Mfr's value: 1.01
FD30	Pressure set-point 7 on appointed date	Setting range: FA05~FA03	Mfr's value: 0.0
FD31	Starting time 8 on appointed date	Setting range: 01.01~12.31	Mfr's value: 1.01
FD32	Stopping time 7 on appointed date	Setting range: 01.01~12.31	Mfr's value: 1.01
FD33	Pressure set-point 8 on appointed date	Setting range: FA05~FA03	Mfr's value: 0.0
FD34	Starting time 1 at weekend	Setting range: 0.00~23.59	Mfr's value: 0.00
FD35	Stopping time 1 at weekend	Setting range: 0.00~23.59	Mfr's value: 0.00
FD36	Pressure set-point 1 at weekend	Setting range: FA05~FA03	Mfr's value: 0.0
FD37	Starting time 2 at weekend	Setting range: 0.00~23.59	Mfr's value: 0.00
FD38	Stopping time 2 at weekend	Setting range: 0.00~23.59	Mfr's value: 0.00
FD39	Pressure set-point 2 at weekend	Setting range: FA05~FA03	Mfr's value: 0.0
FD40	Starting time 3 at weekend	Setting range: 0.00~23.59	Mfr's value: 0.00
FD41	Stopping time 3 at weekend	Setting range: 0.00~23.59	Mfr's value: 0.00
FD42	Pressure set-point 3 at weekend	Setting range: FA05~FA03	Mfr's value: 0.0
FD43	Starting time 4 at weekend	Setting range: 0.00~23.59	Mfr's value: 0.00
FD44	Stopping time 4 at weekend	Setting range: 0.00~23.59	Mfr's value: 0.00
FD45	Pressure set-point 4 at weekend	Setting range: FA05~FA03	Mfr's value: 0.0
FD46	Starting time 5 at weekend	Setting range: 0.00~23.59	Mfr's value: 0.00
FD47	Stopping time 5 at weekend	Setting range: 0.00~23.59	Mfr's value: 0.00
FD48	Pressure set-point 5 at weekend	Setting range: FA05~FA03	Mfr's value: 0.0
FD49	Starting time 6 at weekend	Setting range: 0.00~23.59	Mfr's value: 0.00
FD50	Stopping time 6 at weekend	Setting range: 0.00~23.59	Mfr's value: 0.00
FD51	Pressure set-point 6 at weekend	Setting range: FA05~FA03	Mfr's value: 0.0
FD52	Starting time 7 at weekend	Setting range: 0.00~23.59	Mfr's value: 0.00
FD53	Stopping time 7 at weekend	Setting range: 0.00~23.59	Mfr's value: 0.00

FD54	Pressure set-point 7 at weekend	Setting range: FA05~FA03	Mfr's value: 0.0
FD55	Starting time 8 at weekend	Setting range: 0.00~23.59	Mfr's value: 0.00
FD56	Stopping time 8 at weekend	Setting range: 0.00~23.59	Mfr's value: 0.00
FD57	Pressure set-point 8 at weekend	Setting range: FA05~FA03	Mfr's value: 0.0
FD58	Starting time 1 on workday	Setting range: 0.00~23.59	Mfr's value: 0.00
FD59	Stopping time 1 on workday	Setting range: 0.00~23.59	Mfr's value: 0.00
FD60	Pressure set-point 1 on workday	Setting range: FA05~FA03	Mfr's value: 0.0
FD61	Starting time 2 on workday	Setting range: 0.00~23.59	Mfr's value: 0.00
FD62	Stopping time 2 on workday	Setting range: 0.00~23.59	Mfr's value: 0.00
FD63	Pressure set-point 2 on workday	Setting range: FA05~FA03	Mfr's value: 0.0
FD64	Starting time 3 on workday	Setting range: 0.00~23.59	Mfr's value: 0.00
FD65	Stopping time 3 on workday	Setting range: 0.00~23.59	Mfr's value: 0.00
FD66	Pressure set-point 3 on workday	Setting range: FA05~FA03	Mfr's value: 0.0
FD67	Starting time 4 on workday	Setting range: 0.00~23.59	Mfr's value: 0.00
FD68	Stopping time 4 on workday	Setting range: 0.00~23.59	Mfr's value: 0.00
FD69	Pressure set-point 4 on workday	Setting range: FA05~FA03	Mfr's value: 0.0
FD70	Starting time 5 on workday	Setting range: 0.00~23.59	Mfr's value: 0.00
FD71	Stopping time 5 on workday	Setting range: 0.00~23.59	Mfr's value: 0.00
FD72	Pressure set-point 5 on workday	Setting range: FA05~FA03	Mfr's value: 0.0
FD73	Starting time 6 on workday	Setting range: 0.00~23.59	Mfr's value: 0.00
FD74	Stopping time 6 on workday	Setting range: 0.00~23.59	Mfr's value: 0.00
FD75	Pressure set-point 6 on workday	Setting range: FA05~FA03	Mfr's value: 0.0
FD76	Starting time 7 on workday	Setting range: 0.00~23.59	Mfr's value: 0.00
FD77	Stopping time 7 on workday	Setting range: 0.00~23.59	Mfr's value: 0.00
FD78	Pressure set-point 7 on workday	Setting range: FA05~FA03	Mfr's value: 0.0
FD79	Starting time 8 on workday	Setting range: 0.00~23.59	Mfr's value: 0.00
FD80	Stopping time 8 on workday	Setting range: 0.00~23.59	Mfr's value: 0.00
FD81	Pressure set-point 8 on workday	Setting range: FA05~FA03	Mfr's value: 0.0

5.14 Parameters of the second motor

Please refer to Appendix 6 for the related function code, and please refer to F8 section for parameters explanations.

5.15 Parameters Display

H000 Running frequency/target frequency(Hz)		
In stopped status, target frequency is displayed. In running status, running frequency is displayed.		
H001 Actual speed/target speed (rpm)		
In stopped status, actual speed is displayed. In running status, target speed is displayed.		
H002 Output current (A)		
In running status, output current is displayed. In stopped status, H002=0.		
H003 Output voltage (V)		
In running status, output voltage is displayed. In stopped status, H003=0.		
H004 Bus voltage (V)		
Bus voltage is displayed by H004.		
H005 PID feedback (%)		
PID feedback value is displayed by H005.		
H006 Temperature (°C)		
Inverter temperature is displayed by H006.		
H007 Count value		
The count value of DI1 input impulse is displayed by H007.		
H008 linear speed		
Inverter linear speed is displayed by H008.		
H009 PID setting value (%)		
PID setting value is displayed by H009.		
H012 Output power (KW)		
Inverter output power is displayed by H012.		
H013 Output torque (%)		
H014 Target torque (%)		
Inverter output torque is displayed by H013 and target torque is displayed by H014.		
H016 Limit-voltage Reference Value		
H016 is used to display limit-voltage reference value.		
H017 Current stage speed for multi-stage speed		
In multi-stage speed mode, current stage speed is displayed by H017.		
H018 Frequency of input pulse		
Input pulse frequency of DI1 terminal is displayed by H018, the unit is 0.01		
H019 Feedback speed (Hz)		

EM30

H020	Feedback Speed (rpm)		
------	----------------------	--	--

Feedback speed is displayed as frequency by H019. Feedback speed is displayed as speed by H020.

H021	AI1 voltage(digital)		
H022	AI2 voltage(digital)		

Analog input voltage is display by H021 and H022.

H024	Motor temperature (rpm)		
------	-------------------------	--	--

H024 displays the current motor temperature. When the motor temperature measurement is invalid (F772=0), H024=0.

H025	Current power-on time (minute)		
H026	Current running time (minute)		

Current power-on time and running time are displayed by H025 and H026.

H027	Input pulse frequency(Hz)		
------	---------------------------	--	--

Input pulse frequency is displayed by H027, the unit is 1Hz.

H028	Communication setting value		
------	-----------------------------	--	--

H029	Accumulated running time (S)		
------	------------------------------	--	--

H030	Main frequency source X (Hz)		
------	------------------------------	--	--

H031	Accessorial frequency source Y(Hz)		
------	------------------------------------	--	--

Main frequency and accessorial frequency are displayed by H030 and H031.

H032	Communication status of master/slave		
------	--------------------------------------	--	--

·It displays the communication status of the present inverter and other inverters.

H035	Slave number		
------	--------------	--	--

·It display the quantity of salve inverter

H036	Accumulated power-on time(h)		
------	------------------------------	--	--

H037	Accumulated running time(h)		
------	-----------------------------	--	--

H038	low-level power consumption(kW.H)		
------	-----------------------------------	--	--

H039	High-level power consumption(MW.H)		
------	------------------------------------	--	--

Total power consumption=(H039*1000 + H038)kW.H.

H040	Inlet pressure(%)		
------	-------------------	--	--

VI. Maintenance

Because the potential malfunctions may be caused by the influence of environmental temperature, humidity, dust and vibration, or aging and wearing components of internal inverter, daily inspection and periodic maintenance are necessary for inverter.

Be aware that check the content below to avoid electric shock hazard before inspection and maintenance:

1. The inverter's power is shut off.
2. The power indicator is off after opening the front cover.
3. Measure if the voltage between P/+ and N/- is below 36V with DC static high voltage meter.

6.1. Daily Inspection

Some unexpected situation may happen during operation, user should follow the reminder below to make daily inspection. Maintain a good operation environment; record daily operating data and find out abnormal cause earlier are good ways for prolonging the service life of inverter.

Daily Inspection Reminder

Checking objects	Inspection			Standard
	Content	Period	Methods	
Operation Environment	Temperature and humidity	Anytime	Thermometer and hygrometer	-10℃～+50℃, +50℃～+60℃ Derating
	Dust and water leakage		Visual Check	No water leakage trace
	Gases		Olfaction	No peculiar smell
Inverter	Vibration and heating	Anytime	Touch cover	Steady vibration and reasonable temperature
	Noise		Audition	No abnormal voice
Motor	Heating	Anytime	Touch	No abnormal heating
	Noise		Auditory	Well-balanced voice
Running Status	Output current	Anytime	Ampere meter	Within rated range
	Output voltage		Voltmeter	Within rated range

6.2. Periodic Maintenance

According to the operating environment, the inverter can be checked periodically every 3 or 6 months.

Note:

1. Disassemble components, maintenance and exchange can only be performed by specialized staff.
2. Do not leave any metal parts like screws or gaskets in machine, or damage may happen.

Inspection Content:

1. Clean cooling fan and air channel regularly and check if it is normal; Clean dust inside regularly.
2. Check input/output connections regularly to see if there is arcing in terminals or the wire is aging.
3. Check that the binding screw of each terminal is fastened.
4. Check that any damage of power cable and control cable, especially the incised wound of the wrapper contact with metal surface.
5. Clean the dust on the surface of PCB and air channel, vacuum cleaner is better.
6. At least one time power-on test must proceed within 2 years for Inverters of long-term storage. Use voltage regulator to raise rated value gradually, which during time is around 5 hours without load.
7. For the insulation test to inverter, grounding test must proceed after shorting all the input/output terminals

(L1/R, L2/S, L3/T, U, V, W, PE, P/+ , N/- and B/BR) of main loop with wires. Single-terminal grounding test is prohibited. Tramegger of 500V is required.

8. For the insulation test to motor, input terminals U, V, W of motor must be taken apart from inverter at first, then test motor separately to avoid damage of inverter.

9. Hi-Pot test has passed before leaving factory, user does not need to test again.

10. Changing original components of inverter with different model or electrical parameter may cause damage.

6.3. Exchange of Vulnerable parts

The main vulnerable parts of inverter are cooling fan and filter electrolytic capacitor, which life is closely related to the operation environment and maintenance situation.

1. Cooling fan

The service life of cooling fan is 2~3 years normally. User can change cooling fan according to operation time.

Cause of damage: bearing wear, leaf aging.

Distinguish standard: any cracks on fan blade, abnormal vibration voice when power-on.

2. Filter electrolytic capacitor

The service life is around 4~5 years. User can change based on the operation time.

Cause of damage: poor quality of input power, high temperature, frequent load jumps, aging electrolyte.

Distinguish standard: liquid leakage, safety valve bulge, measurement of electrostatic capacity and insulation resistance.

3. Relay

The service life is 100 thousand times. User can change according to the operation time.

Cause of damage: corrosion, frequent movement.

Distinguish standard: open-close failure

6.4. Storage

Notice when temporary and long-term storage:

1. Try the best to put in the packing case as-is when storage.

2. Ensure good ventilation and keep away from the location of high-temperature, humidity and full of dust or metal dust.

3. Ensure charging every half year and the conduction time is at least 5 hours avoid the degradation of capacitor because of long-term storage.

VII. Motor

7.1. Motor Nameplate

7.1.1. Nameplate of EVPM motor

Three-Phase PM Motor			
Model: EVPM-751IN4Y071D15A03		IEC60034	
380V	3~Mot	4 Pole	0.75 kW
1500 rpm	eff. 85.6%	1.7 A	4.8 N•m
⊙ Tmax. 9.6 N•m	16.5Ω		⊙ 227.3mH
Ke 120 V/krpm	Y-connecting		S1
No. *****	Date:*****		5.4kg
CE			

7.2. Naming Rule

7.2.1. EVPM Motor Naming Rule:

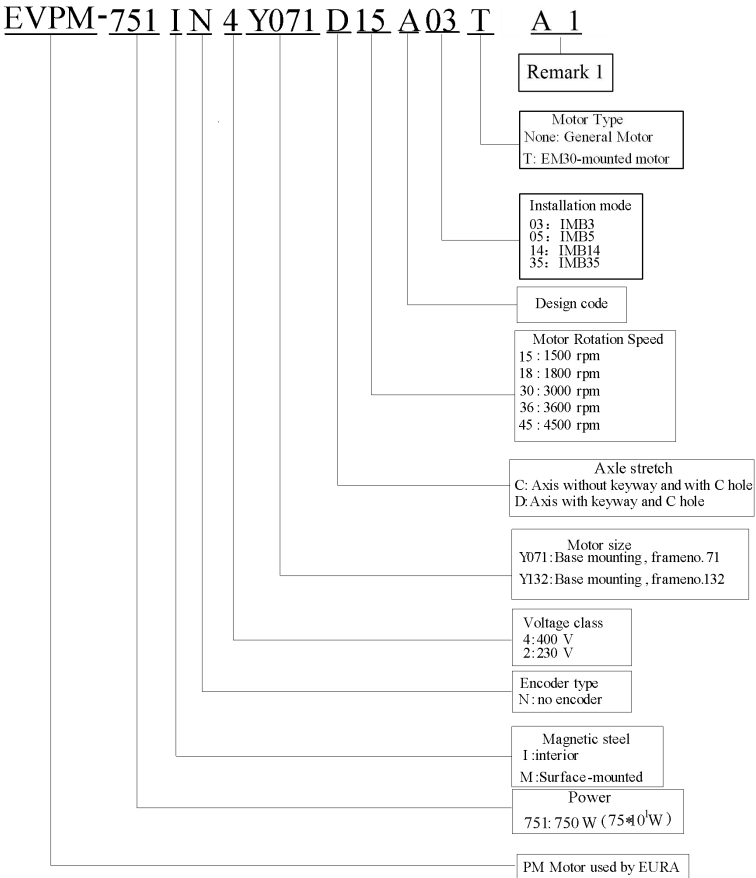

Remark 1:

- A-Bearing Type: (1) None: Deep-groove ball bearing(horizontal, flange mounted)
 (2) Angular contact bearing (vertical-mounted, axis down)
 (3) Angular contact bearing (vertical-mounted, axis up)

I-Junction box location: (1) None: Close to shaft end; (2)1: Close to fan end;

Note: Motor Size includes:

Y063	Base mounting, frame no. 63	Y112	Base mounting, frame no. 112
Y071	Base mounting, frame no. 71	Y132	Base mounting, frame no. 132
Y090	Base mounting, frame no. 90	Y160	Base mounting, frame no. 160

7.3. Motor Technical Specification

Table 7-1 EVPM motor technical specification

Motor Model	PM Motor (Permanent-magnet)	
Magnetic material	Highest intrinsic coercivity rare earth permanent materials	
Motor Power	0.75~11KW	0.4~2.2KW
Rated voltage	400V	220V
Rotor magnet steel	Interior (Significant difference for inductance of DQ axis)	
Magnetic steel	Demagnetization temperature \geq 130 $^{\circ}$ C	
Cooling fan	Rotate with motor shaft in same speed, called coaxial fan	
Installation type	Standard IMB3, meanwhile satisfy with IMB5, 35 and 14	
Protection grade	IP55	
Temperature rise	Surface temperature rise \leq 50 $^{\circ}$ C when motor runs continuously at rated load	
Certification	CE Certification(IEC 60034)	
Motor efficiency	Meet the standard of IE4	

7.4. Motor Type

7.4.1. EVPM motor type list

Motor Model	Pole No.	Rotate Speed (rpm)	Rated Current (A)	Rated Torque (Nm)	Momentary Overload Capacity (Nm)
EVPM-751N4Y071D15A**	4	1500	1.7	4.8	9.6
EVPM-112N4Y071D15A**	4	1500	2.45	7	14
EVPM-152N4Y090D15A**	4	1500	3.3	9.6	19.2
EVPM-222N4Y090D15A**	4	1500	4.7	14	28
EVPM-302N4Y090D15A**	4	1500	6.4	19.1	38.2
EVPM-402N4Y112D15A**	4	1500	8.6	25.5	51.2
EVPM-552N4Y112D15A**	4	1500	11.6	35	70
EVPM-752N4Y112D15A**	4	1500	16	47.8	95.6
EVPM-113N4Y132D15A**	4	1500	22	70	140

EVPM-751IN4Y071D30A**	4	3000	1.7	2.4	4.8
EVPM-112IN4Y071D30A**	4	3000	2.45	3.5	7
EVPM-152IN4Y090D30A**	4	3000	3.3	4.8	9.6
EVPM-222IN4Y090D30A**	4	3000	4.7	7	14
EVPM-302IN4Y090D30A**	4	3000	6.4	9.55	19.2
EVPM-402IN4Y112D30A**	4	3000	8.6	12.8	25.6
EVPM-552IN4Y112D30A**	4	3000	11.6	17.5	35
EVPM-752IN4Y112D30A**	4	3000	16	24	48
EVPM-113IN4Y132D30A**	4	3000	22	35	70
EVPM-201IN4Y063D30A03*	4	3000	0.6	0.635	1.27
EVPM-401IN4Y063D30A03*	4	3000	1.2	1.27	2.54
EVPM-201IN4Y063D15A03*	4	1500	0.6	1.27	2.54
EVPM-401IN4Y063D15A03*	4	1500	1.2	2.54	5.08
EVPM-401IN2Y063D15A03*	4	1500	2.4	2.54	5.08
EVPM-751IN2Y071D15A03*	4	1500	3.4	4.8	9.6
EVPM-112IN2Y071D15A03*	4	1500	4.9	7	14
EVPM-152IN2Y090D15A03*	4	1500	6.6	9.6	19.2
EVPM-222IN2Y090D15A03*	4	1500	9.4	14	28
EVPM-401IN2Y063D30A03*	4	3000	2.4	1.27	2.54
EVPM-751IN2Y071D30A03*	4	3000	3.4	2.4	4.8
EVPM-112IN2Y071D30A03*	4	3000	4.9	3.5	7
EVPM-152IN2Y090D30A03*	4	3000	6.6	4.8	9.6
EVPM-222IN2Y090D30A03*	4	3000	9.4	7	14

Note: * means: None: general motor; T: EM30-mounted motor

7.5. Reference Table of inverter and motor

7.5.1. Reference Table of inverter and EVPM motor

EM30 Inverter Model	Power(KW)	EVPM Motor Model
EM30-0007S2J1U1F2 (AC02/4)(B1)(R3)M2	0.75	EVPM-751IN2Y071D15A03*
		EVPM-751IN2Y071D30A03*
EM30-0015S2J1U1F2 (AC02/4)(B1)(R3)M2	1.5	EVPM-152IN2Y090D30A03*
		EVPM-152IN2Y090D15A03*
EM30-0022S2J1U1F2 (AC02/4)(B1)(R3)M2	2.2	EVPM-222IN2Y090D30A03*
		EVPM-222IN2Y090D15A03*
EM30-0030T2J1U1F2 (AC02/4)(B1)(R3)M2	3.0	Custom-made motor models

EM30-0040T2J2U1F2 (AC02/4)(B1)(R3)M2	4.0	
EM30-0055T2J2U1F2 (AC02/4)(B1)(R3)M2	5.5	
EM30-0007T3J1U1F2 (AC02/4)(B1)(R3)M2	0.75	EVPM-751IN4/3Y071D30A03*
		EVPM-751IN4/3Y071D15A03*
EM30-0015T3J1U1F2 (AC02/4)(B1)(R3)M2	1.5	EVPM-152IN4/3Y090D30A03*
		EVPM-152IN4/3Y090D15A03*
EM30-0022T3J1U1F2 (AC02/4)(B1)(R3)M2	2.2	EVPM-222IN4/3Y090D30A03*
		EVPM-222IN4/3Y090D15A03*
EM30-0030T3J1U1F2 (AC02/4)(B1)(R3)M2	3.0	EVPM-302IN4/3Y090D30A03*
		EVPM-302IN4/3Y090D15A03*
EM30-0040T3J1U1F2 (AC02/4)(B1)(R3)M2	4.0	EVPM-402IN4/3Y112D30A03*
		EVPM-402IN4/3Y112D15A03*
EM30-0055T3J2U1F2 (AC02/4)(B1)(R3)M2	5.5	EVPM-552IN4/3Y112D30A03*
		EVPM-552IN4/3Y112D15A03*
EM30-0075T3J2U1F2 (AC02/4)(B1)(R3)M2	7.5	EVPM-752IN4/3Y112D30A03*
		EVPM-752IN4/3Y112D15A03*
EM30-0110T3J2U1F2 (AC02/4)(B1)(R3)M2	11	EVPM-113IN4Y132D30A**
		EVPM-113IN4Y132D15A**

7.6. Motor Installation Size

7.6.1. EM30 Installation Size

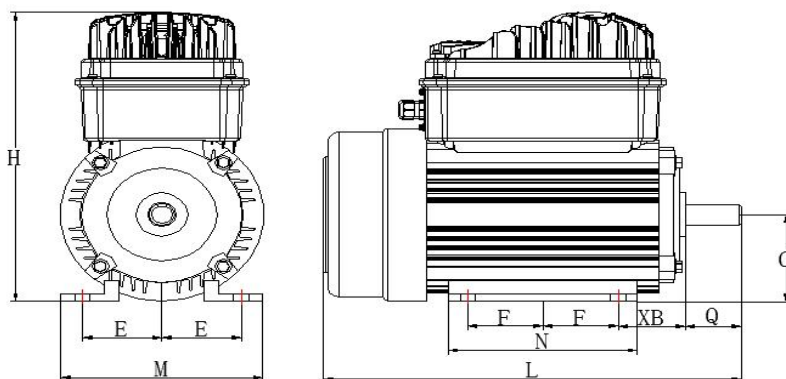

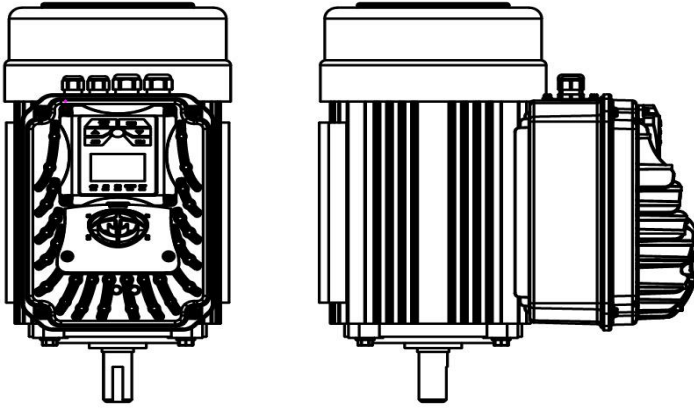

Angular contact bearing (vertical-mounted, axis up)

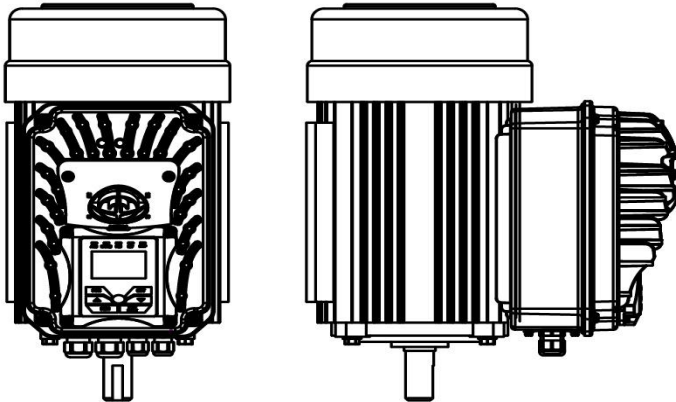

Angular contact bearing (vertical-mounted, axis down)

EM30 overall dimensions

Model	Frame	E	F	XB	Q	C	L	H	M
-------	-------	---	---	----	---	---	---	---	---

EM30-0004S2J1U1F2 (AC02/4)(B1)(R3)M1	63	50	40	40	23	63	230	290	135
EM30-0007S2J1U1F2 (AC02/4)(B1)(R3)M1	71	56	45	45	30	71	255	305	150
EM30-0015S2J1U1F2 (AC02/4)(B1)(R3)M1	90S	70	50	56	50	90	320	360	180
	90L	70	62.5	56	50	90	345	360	180
EM30-0022S2J1U1F2 (AC02/4)(B1)(R3)M1	90S	70	50	56	50	90	320	360	180
	90L	70	62.5	56	50	90	345	360	180
EM30-0007T2J1U1F2 (AC02/4)(B1)(R3)M1	71	56	45	45	30	71	255	305	150
EM30-0015T2J1U1F2 (AC02/4)(B1)(R3)M1	90S	70	50	56	50	90	320	360	180
	90L	70	62.5	56	50	90	345	360	180
EM30-0022T2J1U1F2 (AC02/4) (B1)(R3)M1	90S	70	50	56	50	90	320	360	180
	90L	70	62.5	56	50	90	345	360	180
EM30-0030T2J1U1F2 (AC02/4)(B1)(R3)M1	Custom-made dimensions								
EM30-0040T2J2U1F2 (AC02/4)(B1)(R3)M1									
EM30-0055T2J2U1F2 (AC02/4)(B1)(R3)M1									
EM30-0007T3J1U1F2 (AC02/4)(B1)(R3)M1									
EM30-0015T3J1U1F2 (AC02/4)(B1)(R3)M1	90S	70	50	56	50	90	320	360	180
	90L	70	62.5	56	50	90	345	360	180
EM30-0022T3J1U1F2 (AC02/4)(B1)(R3)M1	90S	70	50	56	50	90	320	360	180
	90L	70	62.5	56	50	90	345	360	180
EM30-0030T3J1U1F2 (AC02/4)(B1)(R3)M1	100L	80	70	63	60	100	385	380	205
EM30-0040T3J1U1F2 (AC02/4)(B1)(R3)M1	112	95	70	70	60	112	404	440	230
EM30-0055T3J2U1F2 (AC02/4)(B1)(R3)M1	132S	108	70	89	80	132	470	485	270
	132M	108	89	89	80	132	510	485	270
EM30-0075T3J2U1F2 (AC02/4)(B1)(R3)M1	132S	108	70	89	80	132	470	485	270
	132M	108	89	89	80	132	510	485	270
EM30-0007S2J1U1F2 (AC02/4)(B1)(R3)M2	80M	62.5	50	50	40	80	295	330	165
EM30-0015S2J1U1F2 (AC02/4)(B1)(R3)M2	90S	70	50	56	50	90	320	360	180
	90L	70	62.5	56	50	90	345	360	180
EM30-0022S2J1U1F2 (AC02/4)(B1)(R3)M2	90S	70	50	56	50	90	320	360	180
	90L	70	62.5	56	50	90	345	360	180
EM30-0007T3J1U1F2 (AC02/4)(B1)(R3)M2	80M	62.5	50	50	40	80	295	330	165
EM30-0015T3J1U1F2 (AC02/4)(B1)(R3)M2	90S	70	50	56	50	90	320	360	180
	90L	70	62.5	56	50	90	345	360	180
EM30-0022T3J1U1F2 (AC02/4)(B1)(R3)M2	90S	70	50	56	50	90	320	360	180
	90L	70	62.5	56	50	90	345	360	180
EM30-0030T3J1U1F2 (AC02/4)(B1)(R3)M2	100L	80	70	63	60	100	385	380	205
EM30-0040T3J1U1F2 (AC02/4)(B1)(R3)M2	112	95	70	70	60	112	404	440	230
EM30-0055T3J2U1F2 (AC02/4)(B1)(R3)M2	132S	108	70	89	80	132	470	485	270

	132M	108	89	89	80	132	510	485	270
EM30-0075T3J2U1F2 (AC02/4)(B1)(R3)M2	132S	108	70	89	80	132	470	485	270
	132M	108	89	89	80	132	510	485	270
EM30-0110T3J2U1F2 (AC02/4)(B1)(R3)M2	132S	108	70	89	80	132	470	345	270
	132M	108	89	89	80	132	510	345	270

7.7. Installation

1. Check the information of nameplate is satisfy with requirement,
2. Check carefully before installation: If motor has bump or deformation and fasteners have loose or dislocation during transport.
3. Motor shaft cannot be dragged when transferring.
4. Use spring cushion to fasten when fixing the motor.
5. Try the best to avoid the vibration of bearing block.
6. Motor cannot bear stronger axial and radial load.
7. Motor shaft must maintain coaxial with equipment's axle.
8. Measure insulation resistance Ri with megger of 500V to see if it's low. The value of insulation resistance should not lower than the calculation as below:

$$R_i \geq 0.38 \times 2^{(7.5 - 0.1T)} M \Omega \quad \text{T-ambient temperature}$$



Drying treatment should be introduced if the value of insulation resistance is low. Drying treatment can be used in the methods of hot air drying or ohmic heating. Avoid using direct current when ohmic heating. Make the rotor locked and energize by voltage regulator. It is better that the current is not higher than 1/2 of rated current.

7.8. Trouble Shooting

7.8.1. voice phenomena, discrimination and trouble shooting

Voice	Phenomena	Discriminating and trouble shooting
Bearing sounds	<ol style="list-style-type: none"> 1. Irregular metallic sounds on bearing outer ring, which is irrelevant to rotate speed. 2. Gurgle sounds at low velocity, before shut-down or at the beginning of operation. 3. Rustling sounds irrelevant to bearing load. 4. Purring sounds which cycle is proportional to rotary speed or intermittent chewing sounds and bearing is too hot. 5. Purring sounds occasionally, small and irregular noise irrelevant to rotary speed. 	<ol style="list-style-type: none"> 1. Lake of grease. Add more grease or change bearing. 2. Generated by impaction of balls (or rollers). Eliminate gradually after running a while, belong to non-fault noise. 3. Add more grease or change bearings. 4. Scratch on the surface of balls (or rollers). Change bearings. 5. Impurity in bearings. Clean or change bearings.
Electromagnetic noise	<ol style="list-style-type: none"> 1. High-frequency gear whines. 2. Droning sounds and motor cannot start. 	<ol style="list-style-type: none"> 1. Improve chopping frequency. 2. One-phase interruption or electricity deficiency of stator winding.

	3. Humming sound and vibration when motor starts.	3. Stator winding interturn short-circuits or grounding at two points.
Resonance	Droning sound only within the scope of a specific running speed.	Avoid running within this scope, check installation conditions or change motor.

7.8.2. Motor winding short-circuit

- Short-circuit to ground in winding

Shut down motor immediately and fix if there is obvious noise with aggravated vibration and overheat when operation. It is because the damage of winding insulation, the wire of winding is collide with shell or core, which makes short-circuit to ground in winding.

- Short-circuit in winding

It includes in-phase and three-phase winding interturn short-circuits. Their faults forms are similar with short-circuit to ground in winding, the main causes show as below:

- A. Winding, that seriously affected with damp and not dried, directly access to the power supply.
- B. With long-term overload, insulator carbonizes because of overheat.

7.8.3. Motor start-up failure cause, phenomena and treatment

Cause and phenomena	Treatment
1. Wiring error of control equipment. Motor cannot start up.	1. Check and modify electric circuit.
2. Two-phase outage of power supply circuit. There is no voice and motor cannot rotate.	2. Check wire, connector, fuse, actuator, output and motor winding to exclude.
3. One-phase outage. Motor cannot start up but along with humming sound.	3. Same as Treatment 2.
4. Low-voltage power supply.	4. Check if the setting of actuator is suitable. Reset if not suitable.
5. Short-circuit (ground or interphase) in stator winding or open-circuit fault makes starting torque too small to start-up, and electricity makes fuse burn-out occasionally.	5. Check the situation of short circuit and open circuit. Fix by themselves or ask for professionals to fix in accordance with practical situation.
6. Because static load torque is too large or there is foreign matter stuck inside motor, motor cannot start and along with humming sound.	6. Check if motor can be rotated manually in the condition of no load, check if there is foreign matter in motor or change high-power motor.

7.8.4. Motor overheat failure cause, phenomena and treatment

Cause and phenomena	Treatment
1. Mismatching of power.	1. Change high-power motor.
2. Phase-broken of motor, high current caused by short-circuit in winding or over-current protection of inverter.	2. Check and eliminate motor failure.
3. Rub between Stator and rotor, rotate inflexibly or bearings run inner ring or outer ring.	3. Check if there is foreign matter between stator and rotor; Contact with manufacturer if running inner ring or brush coating the matching surface of bearing or end cover.
4. Ambient temperature is too high, poor ventilation or sunlight exposure.	4. Improve the environment.

7.8.5. Motor excessive current failure cause, phenomena and treatment

Cause and phenomena	Treatment
1. Core dislocation of stator and rotor.	1. Adjust axial position of rotor.
2. Number of turns of winding or pitch is less than the original design after fixing motor.	2. Wire wrapping and inserting winding again,
3. Burn core when fixing motor.	3. Taking out coil, which is soaked with paint remover, after heated when fixing.

7.9. Maintenance & Servicing

The motor should be checked and the shell needs to be cleaned regularly. High pressure air should be used for cleaning.

Each time bearing runs 2500h, inspection should be carried out at least once. Power off the motor and examine if there is abnormal (increase of noise, abnormal noise and increase of temperature etc.). Change bearings with same specifications if rotor cannot rotate smoothly because of the over-worn or ruptured bearings.



Warning: Motor is forbidden to flush by water.

Appendix 1 Troubleshooting

When malfunction occurs to inverter, don't run by resetting immediately. Check any causes and get it removed if there is any.

Take counter measures by referring to this manual in case of any malfunctions on inverter. Should it still be unsolved, contact the manufacturer. Never attempt any repairing without due authorization.

Table 1-1 Inverter's Common Cases of Malfunctions

Fault	Description	Causes	Countermeasures
Err0	Prohibition modify function code	* prohibition modify the function code during running process.	* Please modify the function code in stopped status.
Err1	Wrong password	*Enter wrong password when password is valid * Do not enter password when modifying function code.	* Please enter the correct password.
2: O.C.	Over-current	* too short acceleration time * short circuit at output side * locked rotor with motor * Too heavy load. * Parameter tuning is not correct.	*prolong acceleration time; *whether motor cable is broken; *check if motor overloads; *reduce V/F compensation value * measure parameter correctly.
16: OC1	Over-current 1		
51: FCL	fast current limiting		
67: OC2	Over-current 2		
3: O.E.	DC Over-Voltage	*supply voltage too high; *load inertia too big *deceleration time too short; *motor inertia rise again * bad effect of dynamic braking *parameter of rotary speed loop PID is set abnormally.	*check if rated voltage is input; *add braking resistance(optional); *increase deceleration time * Enhancing the dynamic braking effect *set the parameter of rotary speed loop PID correctly. * Change to VF control for centrifugal fan.
4: P.F1.	Input Phase loss	*phase loss with input power	*check if power input is normal; *check if parameter setting is correct.
5: O.L1	Inverter Overload	* load too heavy	*reduce load; *check drive ratio; *increase inverter's capacity
6: L.U.	Under-Voltage Protection	*input voltage on the low side	*check if supply voltage is normal *check if parameter setting is correct.
7: O.H.	Radiator Overheat	*environment temperature too high; *radiator too dirty *install place not good for ventilation; *fan damaged * Carrier wave frequency or compensation curve is too high.	*improve ventilation; *clean air inlet and outlet and radiator; *install as required; *change fan * Decrease carrier wave frequency or compensation curve.
8: O.L2	Motor Overload	* load too heavy	*reduce load; *check drive ratio; *increase motor's capacity
11: ESP	External fault	*External emergency-stop terminal is valid.	*Check external fault.
12: Err3	Current malfunction before running	*Current alarm signal exists before running.	*check if control board is connected with power board well. *ask for help from manufacture.

13: Err2	Parameters tuning wrong	*Do not connect motor when measuring parameters	*please connect motor correctly.	
15: Err4	Current zero excursion malfunction	*Flat cable is loosened. *Current detector is broken.	*check the flat cable. *ask for help from manufacture.	
17: PF0	Output Phase loss	* Motor is broken * Motor wire is loose. * Inverter is broken	* check if wire of motor is loose. * check if motor is broken.	
18: AErr	Line disconnected	* Analog signal line disconnected * Signal source is broken.	* Change the signal line. * Change the signal source.	
58: AEr0	Outlet line disconnected			
73: AEr1	Inlet line disconnected			
19: EP3	Inverter under-load	* Water pump dries up. * Belt is broken. * Equipment is broken.	* Supply water for pump * Change the belt. * Repair the equipment.	
20: EP/EP2				
25: EP4				Stem turn protection
57: EP5				Inlet water shortage
22: nP	Pressure control	* Pressure is too high when negative feedback. * Pressure is too low when positive feedback.	* Decrease the min frequency of PID. * Reset inverter to normal status.	
23: Err5	PID parameters are set wrong,	* PID parameters are set wrong.	* Set the parameters correctly.	
24: SLP	Dormancy protection	* Inverter enters into dormancy status.	* Inverter will quit dormancy status after pressure is normal.	
26: GP	Earth fault protection (1-phase does not have GP protection)	*Motor cable is damaged, short connected to grounding. *Motor isolation is damaged, short connected to grounding. *inverter fault.	*change a new cable. *repair the motor. *contact manufacturer.	
32: PCE	PMSM distuning fault	*motor parameters measurement is wrong. *load is too heavy.	* Measure motor parameters correctly. * Decrease the load.	
35: OH1	PTC overheat protection	*external relay protection.	*check external heat protection equipment.	
45: CE	Communication timeout error	Communication fault	*PC/PLC does not send command at fixed time *Check whether the communication line is connected reliably.	
47: EEEP	EEPROM read/write fault	*interference around *EEPROM is damaged.	* remove interferences *contact manufacturer.	
49: Err6	Watchdog fault	Watchdog timeout	*please check watchdog signal	
50: oPEn	oPEn protection	*oPEn terminal is invalid	*Please check the terminal signal of oPEn	
53: CE 1	Keypad disconnection protection	*Keypad cable is disconnected	*Check keypad cable.	
55: SLP1	Inlet dormancy	Inverter enters into dormancy status.	* Inverter will quit inlet dormancy status after pressure is normal.	

56: nP1	Inlet over-pressure	* Pressure is too high when negative feedback. * Pressure is too low when positive feedback.	* Reset inverter to normal status.
69: EP6	Water leakage protection	Pipe leakage	*check the pipe.
72: ErAT	Pump auto-tuning fault	*wrong parameters setting *auto-tuning fail.	*set auto-tuning parameters again.
74: ErT0	Period parameters setting wrong	Period parameters setting wrong	*Check period parameters setting.
71: FILL	Timeout for filling pipe	The time of filling pipe is higher than FB28.	*Check whether pipe is leaking.
75: ErJA	Pump locking	Pump has foreign objects.	*Check whether pump has foreign objects.
76: SSLP	Solar energy dormancy	Lack of light.	*Check the light.

Table 1-2 **Motor Malfunction and Counter Measures**

Malfunction	Items to Be Checked	Counter Measures
Motor not Running	Wiring correct? Setting correct? Too big with load? Motor is damaged? Malfunction protection occurs?	Get connected with power Check wiring; Checking malfunction; Reduce load; Check Table 1-1
Wrong Direction of Motor Running	U, V, W wiring correct? Parameters setting correct?	To correct wiring Setting the parameters correctly.
Motor Turning but Speed Change not Possible	Wiring correct for lines with given frequency? Correct setting of running mode? Too big with load?	To correct wiring; To correct setting; Reduce load
Motor Speed Too High or Too Low	Motor's rated value correct? Drive ratio correct? Inverter parameters are set in-corrected? Check if inverter output voltage is abnormal?	Check motor nameplate data; Check the setting of drive ratio; Check parameters setting; Check VVVF Characteristic value
Motor Running Unstable	Too big load? Too big with load change? Phase loss? Motor malfunction.	Reduce load; Reduce load change, increase capacity; Correct wiring.
Power Trip	Wiring current is too high?	Check input wiring; Selecting matching air switch; Reduce load; checking inverter malfunction.

Appendix 2 Reference Wiring of water system

1. Fixed mode of 1 inverter driving 2 pumps

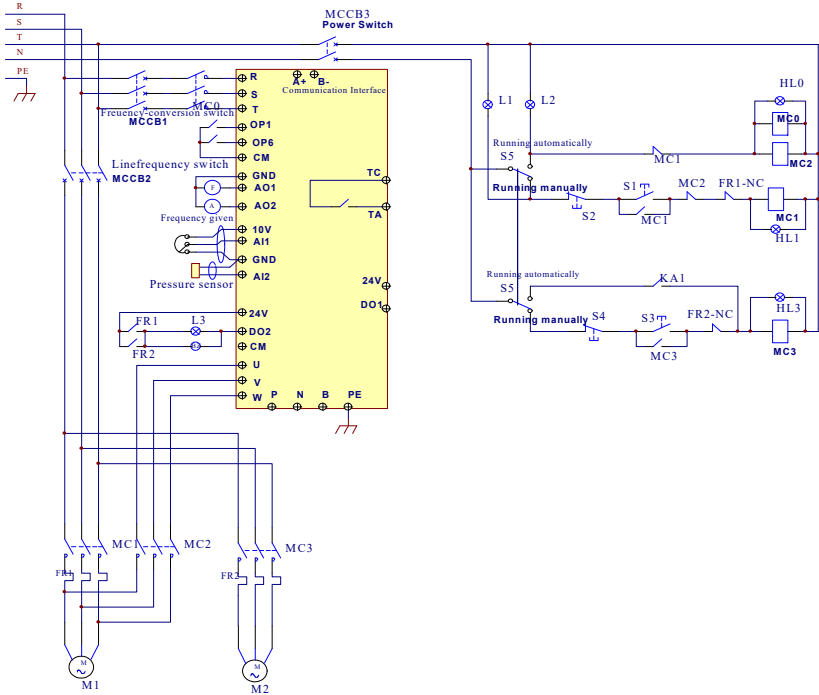

- (1) Please connect the wiring according to above wiring, after checking the wiring and close MCCB3.
- (2) Please set F208=1, F203=9, FA00=1, FA36=1, FA37=1, FA47=1, FA48=2, FA04=pressure percentage, FA03=channel limit pressure, and FA05.
- (3) In manual status, please close power-frequency switch MCCB2. When pressing S1, pump M1 starts working. When pressing S2, M1 stops working. When pressing S3, M2 starts working. When pressing S4, M2 stops working.
- (4) In automatic status, please close converter-frequency switch MCCB1 and power-frequency switch MCCB2.
 - When inverter is powered on, inverter will run forward by short-connecting DI3 terminal (or run reverse by short-connecting DI4 terminal), M1 will work at power frequency status.
 - If the pressure is not high enough, inverter will accelerate to max frequency. If the pressure is still not high enough after duration time FA31, inverter will free stop and pump M2 will start working at power frequency status. After the duration time of FA30, inverter will start working and M1 works at converter frequency status.
 - When two pumps work at the same time, if pressure is too high, inverter will decelerate to min frequency. If the pressure is still too high after the duration time FA32, M2 will stop working.
 - If one pump M1 works at converter frequency status and inverter works at the min frequency, inverter will free stop after the duration time FA10, inverter will enter into dormancy status and nP is displayed.

Appendix 3 Products & Structures

EM30 series inverter has its power range between 0.4~7.5kW. Refer to Tables 3-1 and 3-2 for main data. There may be two (or more than two) kinds of structures for certain products. Please make a clear indication when placing your order.

Inverter should operate under the rated output current, with overload permitted for a short time. However, it shall not exceed the allowable values at working time.

Table 3-1 Product List of EM30

Model	Applicable Motor (kW)	Rated Current Output	Structure Code	Weight (kg)	Cooling Mode	Remarks
EM30-0004S2	0.4	2.5	J0	2.9	Natural-Cooling	1-phase 230V
EM30-0007S2	0.75	4.5	J0	3.0	Air- Cooling	
EM30-0015S2	1.5	7	J0	3.1	Air- Cooling	
EM30-0022S2	2.2	10	J0	3.1	Air- Cooling	
EM30-0004T2	0.4	2.5	J0	2.9	Natural-Cooling	3-phase 230V
EM30-0007T2	0.75	4.5	J1	3.0	Air- Cooling	
EM30-0015T2	1.5	7	J1	3.1	Air- Cooling	
EM30-0022T2	2.2	10	J1	3.1	Air- Cooling	
EM30-0007T3	0.75	2	J0	3.2	Natural-Cooling	3-phase 400V
EM30-0015T3	1.5	4	J0	3.3	Air- Cooling	
EM30-0022T3	2.2	6.5	J0	3.4	Air- Cooling	
EM30-0030T3	3.0	7.6	J0	3.4	Air- Cooling	
EM30-0004S2	0.4	2.5	J1	2.4	Natural-Cooling	1-phase 230V
EM30-0007S2	0.75	4.5	J1	2.5	Air- Cooling	
EM30-0015S2	1.5	7	J1	2.7	Air- Cooling	
EM30-0022S2	2.2	10	J1	2.9	Air- Cooling	
EM30-0004T2	0.4	2.5	J1	2.4	Natural-Cooling	3-phase 230V
EM30-0007T2	0.75	4.5	J1	2.5	Air- Cooling	
EM30-0015T2	1.5	7	J1	2.7	Air- Cooling	
EM30-0022T2	2.2	10	J1	2.8	Air- Cooling	
EM30-0030T2	3.0	12	J1	2.9	Air- Cooling	
EM30-0040T2	4.0	17	J2	6.0	Air- Cooling	
EM30-0055T2	5.5	21	J2	6.1	Air- Cooling	

EM30-0007T3	0.75	2	J1	2.5	Natural-Cooling	3-phase 400V metal wall hanging
EM30-0015T3	1.5	4	J1	2.7	Natural-Cooling	
EM30-0022T3	2.2	6.5	J1	2.8	Air- Cooling	
EM30-0030T3	3.0	7	J1	2.9	Air- Cooling	
EM30-0040T3	4.0	9	J1	3.0	Air- Cooling	
EM30-0055T3	5.5	12	J2	6.1	Air- Cooling	
EM30-0075T3	7.5	17	J2	6.2	Air- Cooling	
EM30-0110T3	11	23	J2	6.3	Air- Cooling	

Table 3-2 Structure List

Structure Code	External Dimension [A×B×H]	Mounting Size(W×L)	Mounting Bolt	Remarks
J0	247×171×157	150×220	M5	Metal Housing
J1	270×190×165	150×262	M5	
J2	338×228×193.5	191×313	M5	

Dimensions unit: mm

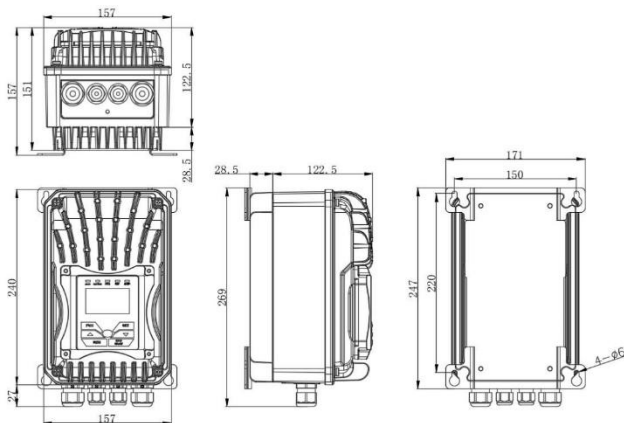

J0 Wall-hanging Dimension Figure

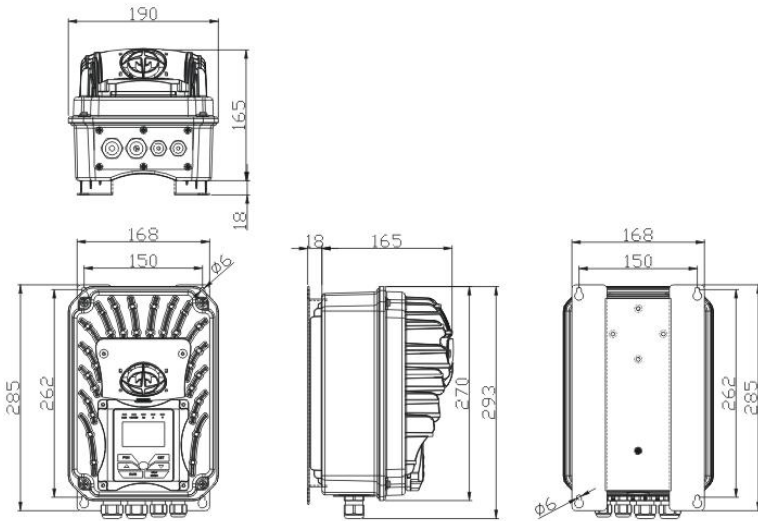

J1 Wall-hanging Dimension Figure

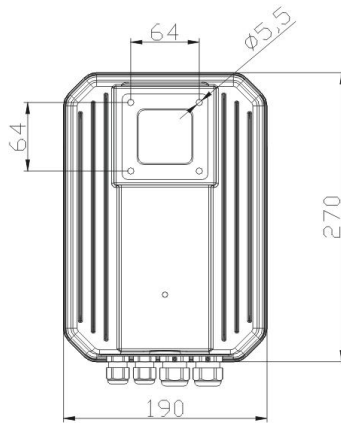

J1 mounted on Motor Dimension Figure

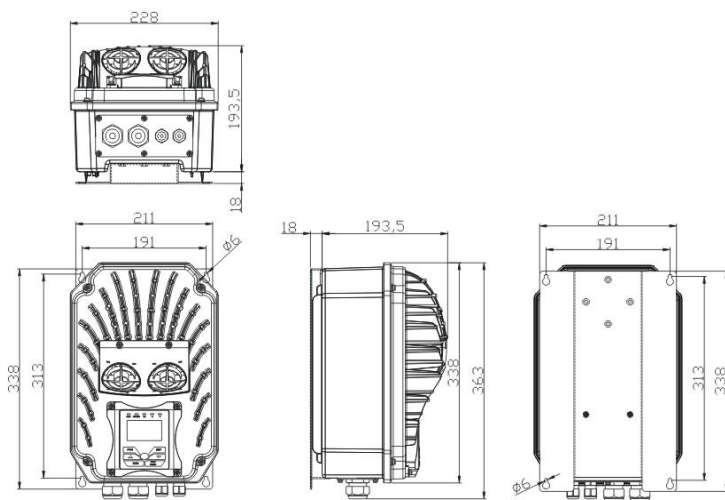

J2 Wall-hanging Dimension Figure

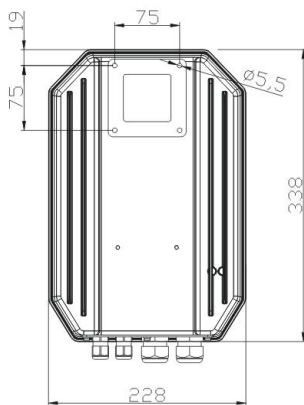

J2 mounted on Motor Dimension Figure

Appendix 4 Selection of Braking Resistance

Inverter model	Applicable motor power (kW)	Min resistor value (Ω)	Min resistor power (W)
EM30-0004S2	0.4	80	200W
EM30-0007S2	0.75		
EM30-0015S2	1.5		
EM30-0022S2	2.2		
EM30-0004T2	0.4		
EM30-0007T2	0.75		
EM30-0015T2	1.5		
EM30-0022T2	2.2		
EM30-0030T2	3.0		
EM30-0040T2	4.0	95	550W
EM30-0055T2	5.5	95	750W
EM30-0007T3	0.75	145	100W
EM30-0015T3	1.5	95	150W
EM30-0022T3	2.2	95	250W
EM30-0030T3	3.0	95	250W
EM30-0040T3	4.0	95	400W
EM30-0055T3	5.5	95	550W
EM30-0075T3	7.5	95	750W
EM30-0110T3	11	50	1.1kW

Note: in the occasion of large inertia load, if the braking resistor heat is serious, please adopt the larger power of resistor than recommended resistor.

Appendix 5 Communication Manual

(Version 1.8)

I. General

Modbus is a serial and asynchronous communication protocol. Modbus protocol is a general language applied to PLC and other controlling units. This protocol has defined an information structure which can be identified and used by a controlling unit regardless of whatever network they are transmitted.

You can read reference books or ask for the details of MODBUS from manufactures.

Modbus protocol does not require a special interface while a typical physical interface is RS485.

II. Modbus Protocol

2.1 Transmission mode

2.1.1 Format

(1) ASCII mode

Start	Address	Function	Data				LRC check		End	
: (0X3A)	Inverter Address	Function Code	Data Length	Data 1	...	Data N	High-order byte of LRC	Low-order byte of LRC	Return (0X0D)	Line Feed (0X0A)

(2) RTU mode

Start	Address	Function	Data	CRC check		End
T1-T2-T3-T 4	Inverter Address	Function Code	N data	Low-order byte of CRC	High-order byte of CRC	T1-T2-T3-T4

2.1.2 ASCII Mode

In ASCII mode, one Byte (hexadecimal format) is expressed by two ASCII characters.

For example, 31H (hexadecimal data) includes two ASCII characters '3(33H)', '1(31H)'.

Common characters, ASCII characters are shown in the following table:

Characters	'0'	'1'	'2'	'3'	'4'	'5'	'6'	'7'
ASCII Code	30H	31H	32H	33H	34H	35H	36H	37H
Characters	'8'	'9'	'A'	'B'	'C'	'D'	'E'	'F'
ASCII Code	38H	39H	41H	42H	43H	44H	45H	46H

2.1.3 RTU Mode

In RTU mode, one Byte is expressed by hexadecimal format. For example, 31H is delivered to data packet.

2.2 Baud rate

Setting range of EM30 series: 1200, 2400, 4800, 9600, 19200, 38400, 57600

2.3 Frame structure:

(1) ASCII mode

Byte	Function
1	Start Bit (Low Level)
7	Data Bit
0/1	Parity Check Bit (None for this bit in case of no checking. Otherwise 1 bit)
1/2	Stop Bit (1 bit in case of checking, otherwise 2 bits)

(2) RTU mode

Byte	Function
1	Start Bit (Low Level)
8	Data Bit
0/1	Parity Check Bit (None for this bit in case of no checking. Otherwise 1 bit)
1/2	Stop Bit (1 bit in case of checking, otherwise 2 bits)

2.4 Error Check

2.4.1 ASCII mode

Longitudinal Redundancy Check (LRC): It is performed on the ASCII message field contents excluding the 'colon' character that begins the message, and excluding the CRLF pair at the end of the message.

The LRC is calculated by adding together successive 8-bit bytes of the message, discarding any carries, and then two's complementing the result.

A procedure for generating an LRC is:

1. Add all bytes in the message, excluding the starting 'colon' and ending CRLF. Add them into an 8-bit field, so that carries will be discarded.
2. Subtract the final field value from FF hex (all 1's), to produce the ones-complement.
3. Add 1 to produce the two-complement.

2.4.2 RTU Mode

Cyclical Redundancy Check (CRC): The CRC field is two bytes, containing a 16-bit binary value. The CRC is started by first preloading a 16-bit register to all 1's. Then a process begins of applying successive 8-bit bytes of the message to the current contents of the register. Only the eight bits of data in each character are used for generating the CRC. Start and stop bits, the parity bit, do not apply to the CRC.

A procedure for generating a CRC-16 is:

- (1) Load a 16-bit register with FFFF hex (all 1's). Call this the CRC register.
- (2) Exclusive OR the first 8-bit byte of the message with the high-order byte of the 16-bit CRC register, putting the result in the CRC register.
- (3) Shift the CRC register one bit to the right (toward the LSB), zero-filling the MSB. Extract and examine the LSB.
- (4) (If the LSB was 0): Repeat Step 3 (another shift).
- (5) (If the LSB was 1): Exclusive OR the CRC register with the polynomial value A001 hex (1010 0000 0000 0001).
- (6) Repeat Steps 3 and 4 until 8 shifts have been performed. When this is done, a complete 8-bit byte will have been processed.
- (7) When the CRC is appended to the message, the low-order byte is appended first, followed by the high-order byte.

2.4.3 Protocol Converter

It is easy to turn a RTU command into an ASCII command followed by the lists:

- 1) Use the LRC replacing the CRC.
- 2) Transform each byte in RTU command into a corresponding two byte ASCII. For example: transform 0x03 into 0x30, 0x33 (ASCII code for 0 and ASCII code for 3).
- 3) Add a 'colon' (:) character (ASCII 3A hex) at the beginning of the message.
- 4) End with a 'carriage return – line feed' (CRLF) pair (ASCII 0D and 0A hex).

So we will introduce RTU Mode in followed part. If you use ASCII mode, you can use the up lists to convert.

2.5 Command Type & Format

2.5.1 The listing below shows the function codes.

code	name	description
03	Read Holding Registers	Read the binary contents of holding registers in the slave. (Less than 10 registers once time)
06	Preset Single Register	Preset a value into holding register

2.5.2 Address and meaning

The part introduces inverter running, inverter status and related parameters setting.

2.5.2.1 Description of rules of function codes parameters address:

- (1) Use the function code as parameter address

General Series:

High-order byte: 01~0A (hexadecimal)

Low-order byte: 00~50 (max range) (hexadecimal) Function code range of each partition is not the same.

The specific range refers to manual.

For example: parameter address of F114 is 010E (hexadecimal).

parameter address of F201 is 0201 (hexadecimal).

For H section, please convert H0 to 43.

For example: the address of H014 is 430E.

Note: in this situation, it allows to read six function codes and write only one function code.

Some function codes can only be checked but cannot be modified; some function codes can neither be checked nor be modified; some function codes cannot be modified in run state; some function codes cannot be modified both in stop and run state.

In case parameters of all function codes are changed, the effective range, unit and related instructions shall refer to user manual of related series of inverters. Otherwise, unexpected results may occur.

- (2) Use different parameters as parameter address

(The above address and parameters descriptions are in hexadecimal format, for example, the decimal digit 4096 is represented by hexadecimal 1000).

2.5.2.2 Running status parameters

Parameters Address	Parameter Description (read only)
1000	Output frequency
1001	Output voltage
1002	Output current
1003	Pole numbers/ control mode, high-order byte is pole numbers, low-order byte is control mode.
1004	Bus-line voltage
1005	Drive ratio/inverter status High-order byte is drive ratio, low-order byte is inverter status Inverter status: 0X00: Standby mode 0X01: Forward running 0X02: Reverse running 0X04: Over-current (OC) 0X05: DC over-current (OE) 0X06: Input Phase loss (PF1) 0X07: Frequency Over-load (OL1) 0X08: Under-voltage (LU) 0X09: Overheat (OH) 0X0A: Motor overload (OL2) 0X0B: Interference (Err) 0X0D: External Malfunction (ESP) 0X0E: Err1 0X0F: Err2 0X10: Err3 0X11: Err4 0X12: OC1 0X13:PF0 0X14: Analog disconnected protection (Aerr) 0X15: EP3 0X16: under-load (EP) 0X17: PP 0X18: Pressure control protection (nP) 0X19: PID parameters are set incorrectly (Err5) 0X21: EP4 0X2F: Communication timeout (CE) 0X33: Watchdog fault (Err6) 0X39: SLP1 0X3A: nP1 0X3B: EP5 0X49: FILL
1006	The percent of output torque
1007	Inverter radiator temperature
1008	PID given value
1009	PID feedback value
100A	Read integer power value: PC/PLC read the integer of power value, discarding the decimal parts
100B	DI terminal status: DI1~DI8—bit0~bit7
100C	Terminal output status : bit0-OUT1 bit1-OUT2(>22kw) bit2-fault relay
100D	AI1: 0~4095 read input analog digital value
100E	AI2: 0~4095 read input analog digital value
100F	AI3: 0~4095 read input analog digital value
1010	Reserved
1011	0~100.00% the percent of input pulse
1012	0~100.00% the percent of output pulse
1013	Monitoring in which stage speed inverter is. 0000 : no function 0001 : stage speed 1 0010 : stage speed 2 0011 : stage speed 3 0100 : stage speed 4 0101 : stage speed 5

	0110 : stage speed 6 1000 : stage speed 8 1010 : stage speed 10 1100 : stage speed 12 1110 : stage speed 14	0111 : stage speed 7 1001 : stage speed 9 1011 : stage speed 11 1101 : stage speed 13 1111 : stage speed 15
1014	Monitoring external counting value	
1015	Monitoring analog output percent, AO1 (0~100.00)	
1016	Monitoring analog output percent, AO2 (0~100.00)	
1017	Monitoring current speed.	
1018	Read accurate power value, and correct the power to 1 decimal place.	
101A	Output current(when the current is too high, data overflow from 1002)	
101B	101A: high 16 bits of output current 101B: low 16 bits of output current	
101C	Transmission ratio	
101D	Inverter is ready.	

Note1: Not every inverter model has all the command type in 2000 for each inverter model.

Note2: Write RAM only allowed when leave factory. Unlock (2001=0003 or F219=0) if changing EEPROM.

2.5.2.2.3 Illegal Response When Reading Parameters

Command Description	Function	Data
Slave parameters response	The highest-order byte changes into 1.	Command meaning: 0001: Illegal function code 0002: Illegal address 0003: Illegal data 0004: Slave fault ^{note 2}

Note 2: Illegal response 0004 appears below two cases:

Parameters Address	Parameters Description (write only)
2000	Command meaning: 0001: Forward running (no parameters) 0002: Reverse running (no parameters) 0003: Deceleration stop 0004: Free stop 0005: Forward jogging start 0006: Forward jogging stop 0007: Reserved 0008: Run (no directions) 0009: Fault reset 000A: Forward jogging stop 000B: Reverse jogging stop 000C: Wakeup
2001	Lock parameters 0001: Relieve system locked (remote control locked) 0002: Lock remote control (any remote control commands are no valid before unlocking) 0003: RAM and eeprom are permitted to be written. 0004: Only RAM is permitted to be written, eeprom is prohibited being written.
2002	AO1 output percent is set by PC/PLC. Setting range: 0~1000 Token output analog is 0~100.0%.
2003	AO2 output percent is set by PC/PLC. Setting range: 0~1000 Token output analog is 0~100.0%.
2004	FO output percent is set by PC/PLC. Setting range: 0~1000 FO token output pulse is 0~100.0%.
2005	To control multi-function output terminal:
2006	1 means token output is valid.
2007	0 means token output is invalid.
2009	Voltage is set by PC/PLC when V/F separation.
2030	PID feedback given
10D	Target frequency (F113)

1. Do not reset inverter when inverter is in the malfunction state.

2. Do not unlock inverter when inverter is in the locked state.

2.5.3 Additional Remarks

Expressions during communication process:

Parameter Values of Frequency=actual value X 100 (General Series)

Parameter Values of Frequency=actual value X 10 (Medium Frequency Series)

Parameter Values of Time=actual value X 10

Parameter Values of Voltage=actual value X 1

Parameter Values of Power=actual value X 100

Parameter Values of Drive Ratio=actual value X 100

Parameter Values of Version No. =actual value X 100

Instruction: Parameter value is the value sent in the data package. Actual value is the actual value of inverter. After PC/PLC receives the parameter value, it will divide the corresponding coefficient to get the actual value.

NOTE: Take no account of radix point of the data in the data package when PC/PLC transmits command to inverter. The valid value is range from 0 to 65535.

III Function Codes Related to Communication

F200	Source of start command	0: Keypad command; 1: Terminal command; 2: Keypad+Terminal; 3:MODBUS; 4: Keypad+Terminal+MODBUS	4
F201	Source of stop command	0: Keypad command; 1: Terminal command; 2: Keypad+Terminal; 3:MODBUS; 4: Keypad+Terminal+MODBUS	4
F203	Main frequency source X	0: Digital setting memory; 1: External analog AI1; 2: External analog AI2; 3: Pulse input given; 4: Stage speed control; 5: Digital given no memory; 6~8: Reserved 9: PID adjusting 10: Modbus	0
F900	Inverter Address	1~255: single inverter address 0: Broadcast address	1
F901	Modbus Mode Selection	1: ASCII mode 2: RTU mode 3: Remote keypad	2
F903	Parity Check	0: Invalid 1: Odd 2: Even	0

F904	Baud Rate	0: 1200 1: 2400 2: 4800 3: 9600 4: 19200 5: 38400 6: 57600 7: 115200	3
------	-----------	---	---

Please set functions code related to communication consonant with the PLC/PC communication parameters, when inverter communicates with PLC/PC.

IV Physical Interface

4.1 Interface instruction

Communication interface of RS485 is located on the most left of control terminals, marked underneath with A+ and B-

4.2 Structure of Field Bus

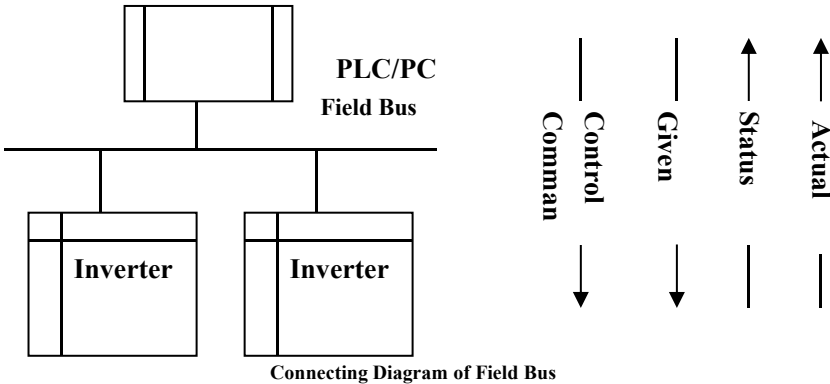

Connecting Diagram of Field Bus

RS485 Half-duplex communication mode is adopted for EM30 series inverter. Daisy chain structure is adopted by 485 Bus-line. Do not use 'spur' lines or a star configuration. Reflect signals which are produced by spur lines or star configuration will interfere in 485 communications.

Please note that for the same time in half-duplex connection, only one inverter can have communication with PC/PLC. Should two or more than two inverters upload data at the same time, then bus competition will occur, which will not only lead to communication failure, but higher current to certain elements as well.

4.3 Grounding and Terminal

Terminal resistance of 120 ohm will be adopted for terminal of RS485 network, to diminish the reflection of signals. Terminal resistance shall not be used for intermediate network.

No direct grounding shall be allowed for any point of RS485 network. All the equipment in the network shall be well grounded via their own grounding terminal. Please note that grounding wires will not form closed loop in any case.

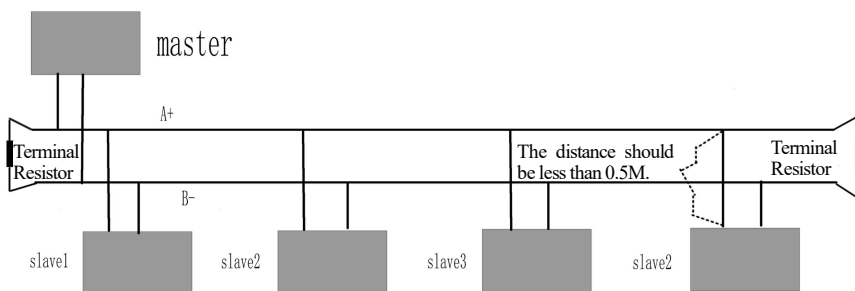

Connecting Diagram of Terminal Resistance

Please think over the drive capacity of PC/PLC and the distance between PC/PLC and inverter when wiring. Add a repeaters if drive capacity is not enough.



All wiring connections for installation shall have to be made when the inverter is disconnected from power supply.

V. Examples

Eg1: In RTU mode, change acc time (F114) to 10.0s in NO.01 inverter.

Query

Address	Function	Register Address Hi	Register Address Lo	Preset Data Hi	Preset Data Lo	CRC Lo	CRC Hi
01	06	01	0E	00	64	E8	1E

Function code F114

Value: 10.0S

Normal Response

Address	Function	Register Address Hi	Register Address Lo	Response Data Hi	Response Data Lo	CRC Lo	CRC Hi
01	06	01	0E	00	64	E8	1E

Function code F114

Normal Response

Abnormal Response

Address	Function	Abnormal code	CRC Lo	CRC Hi
01	86	04	43	A3

The max value of function code is 1. Slave fault

Eg 2: Read output frequency, output voltage, output current and current rotate speed from N0.2 inverter.

Host Query

Address	Function	First Register Address Hi	First Register Address Lo	Register count Hi	Register count L0	CRC Lo	CRC Hi
02	03	10	00	00	04	40	FA

Communication Parameters Address 1000H

Slave Response:

Address	Function	Byte Count	Data Hi	Data Lo	Data Hi	Data Lo	Data Hi	Data Lo	Data Hi	Data Lo	Crc Lo	Crc Hi
02	03	08	13	88	01	90	00	3C	02	00	82	F6

Output Frequency Output Voltage Output Current Numbers of Pole Pairs Control

Mode

NO.2 Inverter's output frequency is 50.00Hz, output voltage is 380V, output current is 6.0A, numbers of pole pairs are 2 and control mode keypad control.

Eg 3: NO.1 Inverter runs forwardly.

Host Query:

Address	Function	Register Hi	Register Lo	Write status Hi	Write status Lo	CRC Lo	CRC Hi
01	06	20	00	00	01	43	CA

Communication parameters address 2000H Forward running

Slave Normal Response:

Address	Function	Register Hi	Register Lo	Write status Hi	Write status Lo	CRC Lo	CRC Hi
01	06	20	00	00	01	43	CA

Normal Response

Slave Abnormal Response:

Address	Function	Abnormal Code	CRC Lo	CRC Hi
01	86	01	83	A0

The max value of function code is 1. Illegal function code (assumption)

Eg4: Read the value of F113, F114 from NO.2 inverter

Host Query:

Address	Function	Register Address Hi	Register Address Lo	Register Count Hi	Register Count L0	CRC Lo	CRC Hi
02	03	01	0D	00	02	54	07

Communication Parameter Address F10DH Numbers of Read Registers

Slave Normal Response:

Address	Function	Byte count	The first parameters status Hi	The first parameters status Lo	The second parameters status Hi	The second parameters status Lo	CRC Lo	CRC Hi
02	03	04	03	E8	00	78	49	61

The actual value is 10.00.

The actual value is 12.00.

Slave Abnormal Response:

Address	Function Code	Abnormal Code	CRC Lo	CRC Hi
02	83	08	B0	F6

The max value of function code is 1.

Parity check fault

Appendix 6 Zoom Table of Function Code

Basic parameters: F100-F160

Parameter	Function Definition	Setting Range	Mfr's Value	Change	Modbus address
F100	User's Password	0~9999	0	√	0x0100
F102	Inverter's Rated Current (A)		Subject to inverter model	△	0x0102
F103	Inverter Power (kW)		Subject to inverter model	△	0x0103
F104	Voltage Level		Subject to inverter model	△	0x0104
F105	Software Edition No.	1.00~10.00	Subject to inverter model	△	0x0105
F106	Control mode	0: Sensorless vector control (SVC); 2: VVVF 3: Vector control 1 6: PMSM sensorless vector control	2	×	0x0106
F107	Password Valid or Not	0: invalid; 1: valid	0	√	0x0107
F108	Setting User's Password	0~9999	8	√	0x0108
F109	Starting Frequency (Hz)	0.0~10.00	0.00	√	0x0109
F110	Holding Time of Starting Frequency (S)	0.0~999.9	0.0	√	0x010A
F111	Max Frequency (Hz)	F113~590.0	50.00	×	0x010B
F112	Min Frequency (Hz)	0.00~F113	0.50	√	0x010C
F113	Target Frequency (Hz)	F112~F111	50.00	√	0x010D
F114	1 st Acceleration Time (S)	0.1~3000	subject to inverter model	√	0x010E
F115	1 st Deceleration Time (S)	0.1~3000		√	0x010F
F116	2 nd Acceleration Time (S)	0.1~3000		√	0x0110
F117	2 nd Deceleration Time (S)	0.1~3000		√	0x0111
F119	Reference of setting accel/decel time	0: 0~50.00Hz 1: 0~max frequency 2: 0~target freq.	0	×	0x0113
F120	Forward/Reverse Switchover dead-Time	0.0~3000	0.0	√	0x0114
F121	VF Torque Compensation	0: Invalid 1: Valid	0	×	0x0115
F122	Reverse Running Forbidden	0: invalid; 1: valid	0	×	0x0116
F123	Minus frequency is valid in the mode of combined speed control.	0: Invalid; 1: valid	0	×	0x0117
F124	Jogging Frequency	F112~F111	5.00Hz	√	0x0118
F125	Jogging Acceleration Time	0.1~3000	subject to inverter model	√	0x0119
F126	Jogging Deceleration Time	0.1~3000		√	0x011A

F127	Skip Frequency A	0.00~590.0	0.00	√	0x011B
F128	Skip Width A	0.00~2.50	0.00	√	0x011C
F129	Skip Frequency B	0.00~590.0	0.00	√	0x011D
F130	Skip Width B	0.00~2.50	0.00	√	0x011E
F131	Running Display Items	0—Present output frequency / function code 1—Current output rotary speed 2—Output current 4—Output voltage 8—PN voltage 16—PID feedback value 32—Temperature 64—Count values 128—Linear speed 256—PID set value 2048—Output power 4096— Output torque	0+1+2+4+8=15	√	0x011F
F132	Display items of stop	0:frequency/function code 2: Target rotary speed 4: PN voltage 8: PID feedback value 16: Temperature 32: Count values 64: PID given value 512: Setting torque	2+4=6	√	0x0120
F133	Drive Ratio of Driven System	0.10~200.0	1.0	√	0x0121
F134	Transmission-wheel radius	0.001~1.000 (m)	0.001	√	0x0122
F135	User macro	0: Invalid 1:user macro 1 2: user macro 2	0	×	0x0123
F136	Slip compensation	0~10	0	×	0x0124
F137	Modes of torque compensation	0: Linear compensation; 1: Square compensation; 2: User-defined multipoint compensation 3: Auto torque compensation 4: V/F separation	0	×	0x0125
F138	Linear compensation	1~20	subject to inverter model	×	0x0126
F139	Square compensation	1: 1.5; 2: 1.8; 3: 1.9; 4: 2.0	1	×	0x0127
F140	Voltage compensation point frequency (Hz)	0~F142	1.00	×	0x0128
F141	Voltage compensation point 1 (%)	0~30	subject to inverter model	×	0x0129

F142	User-defined frequency point 2 (Hz)	F140~F144	5.00	×	0x012A
F143	User-defined voltage point 2(%)	0~100	13	×	0x012B
F144	User-defined frequency point 3 (Hz)	F142~F146	10.00	×	0x012C
F145	User-defined voltage point 3(%)	0~100	24	×	0x012D
F146	User-defined frequency point 4 (Hz)	F144~F148	20.00	×	0x012E
F147	User-defined voltage point 4(%)	0~100	45	×	0x012F
F148	User-defined frequency point 5 (Hz)	F146~F150	30.00	×	0x0130
F149	User-defined voltage point 5(%)	0~100	63	×	0x0131
F150	User-defined frequency point 6 (Hz)	F148~F810	40.00	×	0x0132
F151	User-defined voltage point 6(%)	0~100	81	×	0x0133
F152	Output voltage corresponding to turnover frequency	10~100	100	×	0x0134
F153	Carrier frequency setting	Subject to inverter model	Subject to inverter model	×	0x0135
F154	Automatic voltage rectification	Setting range: 0: Invalid 1: Valid 2:Invalid during deceleration process	0	×	0x0136
F155	Digital accessorial frequency setting	0~F111	0	×	0x0137
F156	Digital accessorial frequency polarity setting	0~1	0	×	0x0138
F157	Reading accessorial frequency			△	0x0139
F158	Reading accessorial frequency polarity			△	0x013A
F159	Random carrier-wave frequency selection	0: Control speed normally(Prohibited); 1: Random carrier-wave frequency(Allowed)	1	×	0x013B
F160	Reverting to manufacturer values	0: Not reverting to manufacturer values; 1: Reverting to manufacturer values	0	×	0x013C

Running control mode: F200-F230

F200	Source of start command	0: Keypad command; 1: Terminal command; 2: Keypad+Terminal; 3:MODBUS; 4: Keypad+Terminal+MODBUS	4	×	0x0200
F201	Source of stop command	0: Keypad command; 1: Terminal command; 2: Keypad+Terminal; 3:MODBUS; 4: Keypad+Terminal+MODBUS	4	×	0x0201
F202	Mode of direction setting	0: Forward running locking; 1: Reverse running locking; 2: Terminal setting	0	×	0x0202
F203	Main frequency source X	0: Digital setting memory; 1: External analog AI1; 2: External analog AI2; 3: Pulse input given; 4: Stage speed control; 5: No memory by digital setting; 7, 8: Reserved; 9: PID adjusting; 10: MODBUS	0	×	0x0203
F204	Accessorial frequency source Y	0: Digital setting memory; 1: External analog AI1; 2: External analog AI2; 3: Pulse input given; 4: Stage speed control; 5: PID adjusting;	0	×	0x0204
F205	Reference for selecting accessorial frequency source Y range	0: Relative to max frequency; 1: Relative to main frequency X	0	×	0x0205
F206	Accessorial frequency Y range	0~100%	100	×	0x0206
F207	Frequency source selecting	0: X; 1: X+Y; 2: X or Y (terminal switchover); 3: X or X+Y (terminal switchover); 4: Combination of stage speed and analog 5: X-Y 6: X+Y-Y _{MAX} *50% 7: Combination of stage speed and analog 1	0	×	0x0207
F208	Terminal two-line/three-line operation control	0: No function; 1: Two-line operation mode 1; 2: Two-line operation mode 2; 3: three-line operation mode 1; 4: three-line operation mode 2; 5: start/stop controlled by direction pulse	0	×	0x0208

F209	Selecting the mode of stopping the motor	0: stop by deceleration time; 1: free stop 2: Stop by DC braking	0	×	0x0209
F210	Frequency display accuracy	0.01~2.00	0.01	√	0x020A
F211	Speed of digital control	0.01~100.00Hz/S	5.00	√	0x020B
F212	Direction memory	0: Invalid 1: Valid	0	√	0x020C
F213	Auto-starting after repowered on	0: invalid; 1: valid	0	√	0x020D
F214	Auto-starting after reset	0: invalid; 1: valid	0	√	0x020E
F215	Auto-starting delay time	0.1~3000.0	60.0	√	0x020F
F216	Times of auto-starting in case of repeated faults	0~5	0	√	0x0210
F217	Delay time for fault reset	0.0~3000.0	3.0	√	0x0211
F219	EEPROM write operation	0:enabled to write 1:prohibit writing	1	√	0x0213
F220	Frequency memory after power-down	0: invalid; 1: valid	0	√	0x0214
F221	X+Y-50%(%)	0~200	50	√	0x0215
F222	count memory selection	0: Invalid 1: Valid	0	√	0x0216
F223	Main Frequency Coefficient	0.0~100.0	100.0	√	0x0217
F224	When target frequency is lower than Min frequency	0: stop 1: run at min frequency	0	×	0x0218
F226	Validity of Skip Frequency	0: Invalid during accelerating/deceleration 1: Invalid during deceleration 2: Always valid	0	×	0x021A
F233	Time Unit of Accel/Decel	0: 0.1s 1: 0.01s	0	√	0x0221
F234	Switchover Frequency During Deceleration Process (Hz)	0.00: Invalid 0.00~F111	0.00	×	0x0222
F277	Third Acceleration Time (S)	Setting range: 0.1~3000	subject to inverter model	√	0x024D
F278	Third Deceleration Time (S)			√	0x024E
F279	Fourth Acceleration Time (S)			√	0x024F
F280	Fourth Deceleration Time (S)			√	0x0250

Multifunctional Input and Output Terminals: F300-F340

F300	Relay 1 token output	0: no function; 1: inverter fault protection; 2: over latent frequency 1; 3: over latent frequency 2; 4: free stop;	1	√	0x0300
F301	DO1 token output	5: in running status 1; 6: Reserved 7: Accel/decel time switchover; 8: Reaching the Set Count Value; 9: Reaching the Designated Count Value; 10: inverter overload pre-alarm; 11: motor overload pre-alarm; 12: stalling; 13: Inverter is ready to run 14: in running status 2; 15: frequency arrival output; 16: overheat pre-alarm; 17: over latent current output 18: Analog line disconnection protection 19: Under-load protection output 20: Zero current detecting output 21: Write DO1 by PC/PLC 22: Write TA2/TC2 by PC/PLC 23: Write TA2/TC2 by PC/PLC 24: Watchdog output token 28: Dormancy 30: General pump is running 31: Converter pump is running 32: Over-limit pressure token 41: Frequency source switchover 43: Communication timeout 1 45: Lower than setting temperature token 56: Irradiation pre-alarm 57: Battery panel bypass 59: oPEn fault	14	√	0x0301
F302	Relay 2 token output		5		0x0302
F303	DO output types selection	0: level output 1 : pulse output	0	√	0x0303
F304	S curve beginning stage proportion (%)	2.0~50.0	30.0	√	0x0304
F305	S curve ending stage proportion (%)	2.0~50.0	30.0	√	0x0305
F306	Accel/decel mode	0: Straight-line 1: S curve	0	×	0x0306
F307	Characteristic frequency 1	F112~F111	10.00	√	0x0307
F308	Characteristic frequency 2	F112~F111	50.00	√	0x0308
F309	Characteristic frequency width (%)	0~100	50	√	0x0309
F310	Characteristic current (A)	0~5000.0	Rated current	√	0x030A
F311	Characteristic current width (%)	0~100	10	√	0x030B

F312	Frequency arrival threshold (Hz)	0.00~5.00	0.00	√	0x030C
F313	Count frequency divisions	1~65000	1	√	0x030D
F314	Set count value	F315~65000	1000	√	0x030E
F315	Designated count value	1~F314	500	√	0x030F
F316	DI1 terminal function setting	0: No function; 1: Running ; 2: Halt; 3: Multi-stage speed 1; 4: Multi-stage speed 2; 5: Multi-stage speed 3; 6: Multi-stage speed 4; 7: Reset; 8: Free stop; 9: External emergency stop; 10: Acceleration/deceleration forbidden terminal; 11: Forward run jogging; 12: Reverse run jogging; 13: UP frequency increasing; 14: DOWN frequency decreasing; 15: "FWD"; 16: "REV"; 17: Three-line type input "X" ; 18: Acceleration/deceleration time switchover 1; 19: Reserved; 20: switchover between speed and torque; 21: frequency source switchover 22: Count input; 23: Count reset 30: Water shortage signal 31: Water signal 32: Fire pressure switchover; 33: Emergency fire control 34: Acceleration / deceleration switchover 2 35: Pulse start 36: Pulse stop 37: Common-open PTC heat protection 38: Common-close PTC heat protection 42: oPEn protection terminal. 44: Pressure selection 1 45: Pressure selection 2 46: Manual pressure selection 47: Auto pressure selection 49: PID pause 51: Motor switchover 53: Watchdog 54: Frequency reset 60: Communication timeout 2 signal	11	√	0x0310
F317	DI2 terminal function setting		9	√	0x0311
F318	DI3 terminal function setting		15	√	0x0312
F319	DI4 terminal function setting		16	√	0x0313
F320	DI5 terminal function setting		7	√	0x0314
F321	DI6 terminal function setting		8	√	0x0315

		elimination 61: Start/stop terminals 71: Water injection 72: Water pump 73: High water level 74: Low water level 75: Pump cleaning 76: Quit fire mode after manual stop 77: Anti-rust and anti-freeze enabled 78: Pressure rising 79: Pressure dropping 80: Pump filling			
F324	Free stop terminal logic	0: positive logic (valid for low level); 1: negative logic (valid for high level)	0	×	0x0318
F325	External emergency stop terminal logic		0	×	0x0319
F326	Watchdog time	0.0: function invalid 0.1~3000.0	10.0	√	0x031A
F327	Stop mode	0: Stop immediately 1: Deceleration to stop	0	×	0x031B
F328	Terminal filter times	1~100	20	√	0x031C
F329	Run command of start terminal	0: Valid 1: Invalid	0	√	0x031D
F330	Status display of digital input terminals			△	0x031E
F331	Monitoring AI1			△	0x031F
F332	Monitoring AI2			△	0x0320
F335	Relay output simulation	0: Output active. 1: Output inactive.	0	×	0x0323
F336	DO1 output simulation		0	×	0x0324
F337	Relay 2 output simulation		0	×	0x0325
F338	AO1 output simulation	0~4095	0	×	0x0326
F339	AO2 output simulation	0~4095	0	×	0x0327
F340	Selection of terminal negative logic	0: Invalid 1: DI1 negative logic 2: DI2 negative logic 4: DI3 negative logic 8: DI4 negative logic 16: DI5 negative logic 32: DI6 negative logic 64: DI7 negative logic 128: DI8 negative logic	0	√	0x0328

F343	Delay Time of DI1 ON	0.00~650.00	0.00	√	0x032B
F344	Delay Time of DI2 ON	0.00~650.00	0.00	√	0x032C
F345	Delay Time of DI3 ON	0.00~650.00	0.00	√	0x032D
F346	Delay Time of DI4 ON	0.00~650.00	0.00	√	0x032E
F347	Delay Time of DI5 ON	0.00~650.00	0.00	√	0x032F
F348	Delay Time of DI6 ON	0.00~650.00	0.00	√	0x0330
F349	Delay Time of DI7 ON	0.00~650.00	0.00	√	0x0331
F350	Delay Time of DI8 ON	0.00~650.00	0.00	√	0x0332
F351	Delay Time of DI1 OFF	0.00~650.00	0.00	√	0x0333
F352	Delay Time of DI2 OFF	0.00~650.00	0.00	√	0x0334
F353	Delay Time of DI3 OFF	0.00~650.00	0.00	√	0x0335
F354	Delay Time of DI4 OFF	0.00~650.00	0.00	√	0x0336
F355	Delay Time of DI5 OFF	0.00~650.00	0.00	√	0x0337
F356	Delay Time of DI6 OFF	0.00~650.00	0.00	√	0x0338
F359	Stop Command Priority	0: Invalid 1: Valid	0	√	0x033B
F360	DO Terminal Negative Logic	0: Invalid 1: DO1 negative logic 2: Relay 2 negative logic 4: Relay 1	0	√	0x033C

Analog Input and Output

F400	Lower limit of AI1 channel input (V)	0.00~F402	0.04	√○	0x0400
F401	Corresponding setting for lower limit of AI1 input	0~2.00	1.00	√	0x0401
F402	Upper limit of AI1 channel input (V)	F400~10.00	10.00	√○	0x0402
F403	Corresponding setting for upper limit of AI1 input	0.00~2.00	2.00	√	0x0403
F404	AI1 channel proportional gain K1	0.0~10.0	1.0	√	0x0404
F405	AI1 filtering time constant (S)	0.01~10.0	0.10	√	0x0405
F406	Lower limit of AI2 channel input (V)	0.00~F408	0.04	√○	0x0406
F407	Corresponding setting for lower limit of AI2 input	0~2.00	1.00	√	0x0407
F408	Upper limit of AI2 channel input (V)	F406~10.00	10.00	√○	0x0408
F409	Corresponding setting for upper limit of AI2 input	0.00~2.00	2.00	√	0x0409
F410	AI2 channel proportional gain K2	0.0~10.0	1.0	√	0x040A
F411	AI2 filtering time constant	0.01~10.00	0.10	√	0x040B
F418	AI1 channel 0Hz voltage dead zone	0.00~1.00	0.00	√	0x0412
F419	AI2 channel 0Hz voltage dead zone	0.00~1.00	0.00	√	0x0413
F423	AO1 output range	0: 0~5V; 1: 0~10V or 0-20mA 2: 4-20mA	1	√	0x0417

F424	AO1 lowest corresponding frequency	0.0~F425	0.05	√	0x0418
F425	AO1 highest corresponding frequency	F424~F111	50.00	√	0x0419
F426	AO1 output compensation	0~120	100	√	0x041A
F427	AO2 output range	0: 0~20mA; 1: 4~20mA	0	√	0x041B
F428	AO2 lowest corresponding frequency	0.0~F429	0.05	√	0x041C
F429	AO2 highest corresponding frequency	F428~F111	50.00	√	0x041D
F430	AO2 output compensation	0~120%	100	√	0x041E
F431	AO1 analog output signal selecting	0: Running frequency; 1: Output current; 2: Output voltage; 3: AI1 4: AI2	0	√	0x041F

F432	AO2 analog output signal selecting	5: Input pulse 6: Output torque 7: Given by PC/PLC 8: Target frequency 9: Actual speed 10: Output torque 2 12: Output power 13:relay 2 output 14: Inlet pressure 15:Outlet pressure	1	√	0x0420
F433	Corresponding current for full range of external voltmeter	0.01~5.00 times of rated current	2.00	×	0x0421
F434	Corresponding current for full range of external ammeter		2.00	×	0x0422
F435	Corresponding multiple of rated power for output max analog value	0.01~3.00	2.00	×	0x0423
F436	Corresponding current multiple of output max analog to rated torque.	0.01~3.00	3.00	×	0x0424
F438	Input Signal of AI1 Channel	0: voltage 1: current	0	×	0x0426
F439	Input Signal of AI2 Channel	0: voltage 1: current	1	×	0x0427
F440	Min frequency of input pulse FI	0.00~F442	0.00	√	0x0428
F441	Corresponding setting of FI min frequency	0.00~F443	1.00	√	0x0429
F442	Max frequency of input pulse FI	F440~100.00	10.00	√	0x042A
F443	Corresponding setting of FI max frequency	Max (1.00, F441) ~2.00	2.00	√	0x042B
F445	Filtering constant of FI input pulse	0~1000	0	√	0x042D
F446	FI channel 0Hz frequency dead zone	0~F442 (Positive-Negative)	0.00	√	0x042E
F448	FI Proportion Gain	0.001~2.000	1.000	√	0x0430
F449	Max frequency of output pulse FO	0.00~100.00	10.00	√	0x0431
F450	Zero bias coefficient of output pulse frequency (%)	0.0~100.0	0.0	√	0x0432
F451	Frequency gain of output pulse	0.00~10.00	1.00	√	0x0433

F453	Output pulse signal	0: Running frequency 1: Output current 2: Output voltage 3: AI1 4: AI2 5: Input pulse 6: Output torque 7: Given by PC/PLC 8: Target frequency 9: Actual speed 10: Output torque 2 12: Output power 13: Relay 2 output 14: Inlet pressure 15:Outlet pressure	0	√	0x0435
F460	AI1 channel input mode	0: straight line mode 1: folding line mode	0	×	0x043C
F461	AI2 channel input mode	0: straight line mode 1: folding line mode	0	×	0x043D
F462	AI1 insertion point A1 voltage value	F400~F464	2.00	×	0x043E
F463	AI1 insertion point A1 setting value	F401~F465	1.20	×	0x043F
F464	AI1 insertion point A2 voltage value	F462~F466	5.00	×	0x0440
F465	AI1 insertion point A2 setting value	F463~F467	1.50	×	0x0441
F466	AI1 insertion point A3 voltage value	F464~F402	8.00	×	0x0442
F467	AI1 insertion point A3 setting value	F465~F403	1.80	×	0x0443
F468	AI2 insertion point B1 voltage value	F406~F470	2.00	×	0x0444
F469	AI2 insertion point B1 setting value	F407~F471	1.20	×	0x0445
F470	AI2 insertion point B2 voltage value	F468~F472	5.00	×	0x0446
F471	AI2 insertion point B2 setting value	F469~F473	1.50	×	0x0447
F472	AI2 insertion point B3 voltage value	F470~F408	8.00	×	0x0448
F473	AI2 insertion point B3 setting value	F471~F409	1.80	×	0x0449
F475	AO1 Output Bias	0~5.00	1.00	√	0x044B
F476	AO2 Output Bias	0~5.00	1.00	√	0x044C

Multi-stage Speed Control: F500-F580

F500	Stage speed type	0: 3-stage speed; 1: 15-stage speed; 2: Max 8-stage speed auto circulating	1	×	0x0500
F501	Selection of Stage Speed Under Auto-circulation Speed Control	2~8	7	√	0x0501
F502	Selection of Times of Auto- Circulation Speed Control	0~9999 (when the value is set to 0, the inverter will carry out infinite circulating)	0	√	0x0502
F503	Status after auto circulation running Finished	0: Stop 1: Keep running at last stage speed	0	√	0x0503
F504	Frequency setting for stage 1 speed	F112~F111	5.00	√	0x0504
F505	Frequency setting for stage 2 speed	F112~F111	10.00	√	0x0505
F506	Frequency setting for stage 3 speed	F112~F111	15.00	√	0x0506
F507	Frequency setting for stage 4 speed	F112~F111	20.00	√	0x0507
F508	Frequency setting for stage 5 speed	F112~F111	25.00	√	0x0508
F509	Frequency setting for stage 6 speed	F112~F111	30.00	√	0x0509
F510	Frequency setting for stage 7 speed	F112~F111	35.00	√	0x050A
F511	Frequency setting for stage 8 speed	F112~F111	40.00	√	0x050B
F512	Frequency setting for stage 9 speed	F112~F111	5.00	√	0x050C
F513	Frequency setting for stage 10 speed	F112~F111	10.00	√	0x050D
F514	Frequency setting for stage 11 speed	F112~F111	15.00	√	0x050E
F515	Frequency setting for stage 12 speed	F112~F111	20.00	√	0x050F
F516	Frequency setting for stage 13 speed	F112~F111	25.00	√	0x0510
F517	Frequency setting for stage 14 speed	F112~F111	30.00	√	0x0511
F518	Frequency setting for stage 15 speed	F112~F111	35.00	√	0x0512
F519-F533	Acceleration time setting for the speeds from Stage 1 to stage 15	0.1~3000	Subject to inverter model	√	0x0513~0x0520
F534-F548	Deceleration time setting for the speeds from Stage 1 to stage 15	0.1~3000		√	0x0522~0x0530
F549-F556	Running directions of stage speeds from Stage 1 to stage 8	0: forward running; 1: reverse running	0	√	0x0531~0x0528
F557-F564	Running time of stage speeds from Stage 1 to stage 8	0.1~3000	1.0	√	0x0539~0x0540
F565-F572	Stop time after finishing stages from Stage 1 to stage 8.	0.0~3000	0.0	√	0x0541~0x0548

F573-F579	Running directions of stage speeds from Stage 9 to stage 15.	0: forward running; 1: reverse running	0	√	0x0542~ 0x054F
F580	Stage-speed mode	0: Stage speed mode 1 1: Stage speed mode 2	0	√	0X0550

Auxiliary Functions: F600-F650

F600	DC Braking Function Selection	0: Invalid; 1: braking before starting; 2: braking during stopping; 3: braking during starting and stopping	0	√	0x0600
F601	Initial Frequency for DC Braking	0.20~50.00	1.00	√	0x0601
F602	DC Braking efficiency before Starting	0~250	50	√	0x0602
F603	DC Braking efficiency During Stop	0~250	100	√	0x0603
F604	Braking Lasting Time Before Starting	0.0~30.00	0.50	√	0x0604
F605	Braking Lasting Time During Stopping	0.0~30.00	0.50	√	0x0605
F606	DC braking mode	0: Voltage mode 1: Current mode	1	×	0x0606
F607	Selection of Stalling Adjusting Function	0~2:Reserved 3: Voltage/current control 4: Voltage control 5: Current control	3	√	0x0607
F608	Stalling Current Adjusting (%)	60~FC49	160	√	0x0608
F609	Stalling Voltage Adjusting (%)	110~200	140	√	0x0609
F610	Stalling protection judging time (s)	0.0~3000	0.0	√	0x060A
F611	Dynamic Braking threshold (V)	320~2000	Subject to model	×	0x060B
F612	Dynamic braking duty ratio (%)	0~100	100	×	0x060C
F613	Speed track enable	0: invalid 1: valid 2: valid at the first time	0	×	0x060D
F614	Speed track mode	Setting range: 0: Speed track from frequency memory 1: Speed track from max frequency 2: Speed track from zero	0	×	0x060E
F615	Speed track rate	1~100	20	×	0x060F
F618	Delay Time of Speed Track (S)	0.5~60.0	1.5	×	0x0612
F620	Brake delay turn-off time (s)	0.0: discharge not closed when stop 0.1~3000	5.0	√	0x0614
F626	Tracking current KP coefficient	0.1~100	1.0	√	0x061A

F627	Tracking current Ki coefficient	0.1~100	1.0	√	0x061B
F628	Tracking current	20~200	60	√	0x061C
F631	DC BUS Voltage adjusting	0: Invalid 1: Valid at steady speed 2: Reserved 3: Always valid	0	√	0x061F
F632	Reference Voltage of DC BUS adjusting (V)	100~2300	Subject to inverter model	√	0x0620
F633	Range for DC BUS Adjusting (Hz)	0~100.00	5.00	√	0x0621
F634	Accelerating Time for DC BUS Adjusting(S)	0.1~3000.0	0.1	√	0x0622
F635	Decelerating Time for DC BUS Adjusting(S)	0.1~3000.0	0.1	√	0x0623
F636	Proportion Gain for DC BUS Adjusting	0.01~20.00	1.00	√	0x0624
F637	Integral Gain for DC BUS Adjusting	0~20.00	1.50	√	0x0625
F638	Parameter copy enable	0: copy forbidden 1: parameter download 1(voltage level and power accordance) 2: parameter download 2(not consider voltage level and power)	1	×	0x0626
F639	Parameter copy codes		Subject to software	△	0x0627
F640	Parameter copy type	0: Total parameters copy 1: Parameter copy (motor F801~F810/F844 not include)	1	×	0x0628
F641	Inhibition of current oscillation at low frequency	0: Invalid 0~100	Subject to model	×	0x0629
F644	Keypad copy enabled	0: Invalid 1: current macro parameter upload 2: current macro parameter download 3: user macro 1 upload 4: user macro 1 download 5: user macro 2 upload 6: user macro 2 download	0	×	0x062C

F645	Status display of inverter	0: Current running frequency 1: Current rotate speed 2: Target rotate speed 3: Output current 4: Output voltage 5: PN voltage 6: PID setting value 7: PID feedback value 8: Radiator temperature 9: Count value 10: Linear speed 11: Main frequency setting channel 12: Main frequency 13: Auxiliary frequency setting channel 14: Auxiliary frequency 15: Target frequency 16: Reserved 17: Output torque 18: Setting torque 19: Motor power 20: Output power 21: Frequency status 22: DI terminal status 23: Output terminal status 24: Current stage of multi-stage speed 25: AI1 input value 26: AI2 input value 27, 28: Reserved 29: Pulse input frequency 30: Pulse output frequency 31: AO1 output percentage 32: AO2 output percentage 33: Power-on time 36: current lightning	0	√	0x062D
F646	LCD backlight time(s)	0~100	100	√	0x062E
F647	Language selection	0: Chinese 1: English 2: Deutsch 3: Espanol 4: Francais	0	√	0x062F
F656	DC braking waiting time during stopping(s)	0.00~30.00	0.00	√○	0x0638
F657	Instantaneous power failure selection	0: Invalid 1: Reduce frequency to remain running 2: Reduce frequency quickly to stop the inverter	0	×	0x0639
F658	Voltage rally acceleration time	0.0~3000 0.0: F114	0.0	√	0x063A
F659	Voltage rally deceleration time	0.0~3000 0.0: F115	0.0	√	0x063B

F660	Action judging voltage at instantaneous power failure	200~F661	Subject to model	×○	0x063C
F661	Action stop voltage at instantaneous power failure	F660~1400	Subject to model	×○	0x063D
F662	Instantaneous voltage recovery judging time(s)	0.00~10.00	0.30	√	0x063E
F663	Instantaneous Proportion Coefficient Kp	0.00~10.00	0.25	√	0x063F
F664	Instantaneous Integral Coefficient Ki	0.00~10.00	0.30	√	0x0640
F670	Voltage-limit current-limit adjustment coefficient	0.01~10.00	2.00	√	0x0646
F671	voltage source for V/F separation	0: F672 1: AI1 2: AI2 4: Communication setting 5: pulse setting 6: PID 7~10: reserved	0	×	0x0647
F672	Voltage digital setting for V/F separation	0.00~100.00	100.00	√	0x0648
F673	Lower limit of voltage at V/F separation (%)	0.00~F674	0.00	×	0x0649
F674	Upper limit of voltage at V/F separation (%)	F673~100.00	100.00	×	0x064A
F675	Voltage rise time of V/F separation	0.0~3000.0	5.0	√	0x064B
F676	Voltage rise time of V/F separation	0.0~3000.0	5.0	√	0x064C
F677	Stop mode at V/F separation	0: voltage and frequency declines to 0 according to respective time. 1: Voltage declines to 0 first 2: frequency declines to 0 first.	0	×	0x064D
F678	Judgment Voltage at V/F Separation	0: Invalid 1: Auto judgement	0	×	0x064E
F679	Voltage Switch Point at V/F Separation(V)	200~600	430	×	0x064F
F680	Switch Point Width at V/F Separation (%)	0.0~100.0	0.5	×	0x0650

Timing Control and Protection: F700-F760

F700	Selection of terminal free stop mode	0: free stop immediately; 1: delayed free stop	0	√	0x0700
F701	Delay time for free stop and programmable terminal action	0.0~60.0	0.0	√	0x0701
F702	Fan control mode	0: controlled by temperature 1: Running when inverter is powered on 2: Controlled by running status	2	×	0x0702
F704	Inverter Overloading pre-alarm coefficient (%)	50~100	80	√	0x0704

F705	Motor overloading adjusting gains	50~100	80	×	0x0705
F706	Inverter Overloading coefficient%	120~190	150	×	0x0706
F707	Motor Overloading coefficient %	20~100	100	×	0x0707
F708	Record of The Latest Malfunction Type	Setting range: 2: Over current (OC) 3: over voltage (OE) 4: input phase loss (PF1) 5: inverter overload (OL1) 6: under voltage (LU) 7: overheat (OH)		△	0x0708
F709	Record of Malfunction Type for Last but One	8: motor overload (OL2) 11: external malfunction (ESP) 13. studying parameters without motor (Err2) 16: Over current 1 (OC1) 17: output phase loss (PF0) 18: Aerr analog disconnected 20: EP/EP2/EP3 under-load 22: nP pressure control		△	0x0709
F710	Record of Malfunction Type for Last but Two	23: Err5 PID parameters are set wrong 45: Communication timeout (CE) 46: Speed track fault (FL) 49: Watchdog fault (Err6)		△	0x070A
F711	Fault Frequency of The Latest Malfunction			△	0x070B
F712	Fault Current of The Latest Malfunction			△	0x070C
F713	Fault PN Voltage of The Latest Malfunction			△	0x070D
F714	Fault Frequency of Last Malfunction but One			△	0x070E
F715	Fault Current of Last Malfunction but One			△	0x070F
F716	Fault PN Voltage of Last Malfunction but			△	0x0710
F717	Fault Frequency of Last Malfunction but			△	0X0711
F718	Fault Current of Last Malfunction but			△	0x0712
F719	Fault PN Voltage of Last Malfunction but			△	0x0713
F720	Record of over-current protection fault			△	0x0714
F721	Record of overvoltage protection fault			△	0x0715
F722	Record of overheat protection fault times			△	0x0716
F723	Record of overload protection fault times			△	0x0717
F724	Input phase loss		Subject to inverter	×	0x0718

F725	Under-voltage protection	0: Reset manually 1: Reset automatically	2	×	0x0719
F726	Overheat	0: invalid; 1: valid	1	○×	0x071A
F727	Output phase loss	0: invalid; 1: valid	1	○	0x071B
F728	Input phase loss filtering constant	1~60	5	√	0x071C
F729	Under-voltage filtering constant(2ms)	1~3000	5	√	0x071D
F730	Overheat protection filtering constant	0.1~60.0	5.0	√	0x071E
F732	Voltage threshold of under-voltage protection	Subject to inverter model	Subject to	×	0x0720
F737	Over-current 1 protection	0: Invalid 1:Valid	1		0x0725
F738	Over-current 1 protection coefficient	0.50~3.00	2.5		0x0726
F739	Over-current 1 protection record			△	0x0727
F741	Analog disconnected protection	0: Invalid 1: Stop and AErr is displayed. 2: Stop and AErr is not displayed. 3: Inverter runs at the min frequency. 4: Switch to stage-speed circulation	0	√	0x0729
F742	Threshold of analog disconnected protection (%)	1~100	50	√	0x072A
F745	Threshold of pre-alarm overheat (%)	0~100	80	√○	0x072D
F746	Carrier frequency auto-adjusting threshold(°C)	60~100	75	√	0x072E
F747	Carrier frequency auto-adjusting	0: Invalid 1: Valid	1	√	0x072F
F751	Instantaneous stop pretreatment enables	0: Invalid 1: Valid	0	√	0x0733
F752	Overload quitting coefficient	0.1~20.0	1.0	√	0x0734
F753	Selection of overload protection	0: Normal motor 1: variable frequency motor	1	×	0x0735
F754	Zero-current threshold (%)	0~200	5	×	0x0736
F755	Duration time of zero-current	0~60.0	0.5	√	0x0737
F756	Delay time for DC bus voltage detection when drive run (ms)	0: Invalid 1~5000	0	√	0x0738
F757	Delay time for DC bus voltage detection when drive stops (S)	0.0~100.0	5.0	√	0x0739
F759	Carrier-frequency Ratio	3~30	15	×	0x073B
F760	Grounding protection	0: Invalid 1: Valid when powering on 2: Valid during running 3: Valid both powering on and running	Subject to model	√	0x073C
F761	Switchover mode of FWD/REV	0: at zero 1: at start frequency	0	×	0x074D
F770	Auxiliary Version No.			△	0x0746
F776	Delay time for grounding test (S)	0.0~3600.0	2.0	√	0x074C

F784	Over-modulation coefficient of output voltage	100~110	105	×	0x0754
------	---	---------	-----	---	--------

Motor parameters: F800-F830

F800	Motor's parameters selection	Setting range: 0: Invalid; 1: Rotating tuning.; 2: Stationary tuning	0	×	0x0800
F801	Rated power(kW)	0.1~1000		×	0x0801
F802	Rated voltage(V)	1~1300		×	0x0802
F803	Rated current(A)	0.2~6553.5		×	0x0803
F804	Number of motor poles	2~100	4	×	0x0804
F805	Rated rotary speed(rpm)	1~30000		×	0x0805
F806	Stator resistance	0.001~65.53Ω (for 15kw and below 15kw) 0.1~6553mΩ (For above 15kw)	Subject to inverter model	×	0x0806
F807	Rotor resistance	0.001~65.53Ω (for 15kw and below 15kw) 0.1~6553mΩ (For above 15kw)	Subject to inverter model	×	0x0807
F808	Leakage inductance	Setting range: 0.01~655.3mH (for 15kw and below 15kw) 0.001~65.53mH (for above 15kw)	Subject to inverter model	×	0x0808
F809	Mutual inductance	Setting range: 0.1~6553mH (for 15kw and below 15kw) 0.01~655.3mH (for above 15 kw)	Subject to inverter model	×	0x0809
F810	Motor rated frequency	1.00~590.0	50.00	×	0x080A
F811	Carrier Frequency Switchover Point (Hz)	0.00~20.00	8.00	√	0x080B
F812	Pre-exciting time	0.00~30.00	0.10	√	0x080C
F813	Rotary speed loop KP1	1~100	Subject to inverter model	√	0x080D
F814	Rotary speed loop KI1	0.01~10.00	0.50	√	0x080E
F815	Rotary speed loop KP2	1~100	Subject to inverter model	√	0x080F
F816	Rotary speed loop KI2	0.01~10.00	1.00	√	0x0810
F817	PID switching frequency 1	0~F818	5.00	√	0x0811
F818	PID switching frequency 2	F817~F111	10.00	√	0x0812
F819	Slip coefficient	50~200	100	√	0x0813
F820	Filtering coefficient of speed loop	0~100	10	√	0x0814
F821	Over Excitation Gain	0.0~100.0	0.0	√	0x0815
F822	Upper limit of speed control torque	0.0~250.0	Subject to inverter model	√	0x0816

F823	Current-loop Proportion Coefficient	0.1~10.0	1.0	√	0x0817
F825	Current-loop Integral Coefficient	0.1~10.0	1.0	√	0x0819
F836	Fast Current Limited	0: Invalid 1: Valid	Subject to inverter model	√	0x0824
F838	SVC Control Mode	1: control mode 1	3	×	0x0826
F839	Flux-weakening Coefficient	0.10~2.00	1.00	√	0x0827
F840	Halt speed detection	0: detection according to feedback 1: detection according to given speed	0	×○	0x0828
F844	Motor current without load (A)	0.1~F803	Subject to model	×○	0x082C
F866	Static Position Identification	0: Invalid 1: Valid 2: Valid for the first-time running	2	×	0x083A
F867	Position Identification Current	0~100	50	×	0x0842
F868	Position Identification	500~16000	16000	×	0x0843
F870	PMSM back electromotive force (mV/rpm)	0.1~6553.0 (valid value between lines)	100.0	×	0x0846
F871	PMSM D-axis inductance (mH)	0.01~655.30	5.00	×	0x0847
F872	PMSM Q-axis inductance (mH)	0.01~655.30	7.00	×	0x0848
F873	PMSM stator resistance (Ω)	0.001~65.530 (phase resistor)	0.500	×	0x0849
F875	Position Identification Angle Compensation	0~1000	0	×○	0x084B
F876	PMSM injection current without load (%)	0.0~100.0	00.0	×	0x084C
F878	PMSM cut-off point of injection current compensation without load (%)	0.0~50.0	10.0	×	0x084E
F879	PMSM injection current with heavy load (%)	0.0~100.0	0.0	×	0x084F
F880	PMSM PCE detection time (S)	0.1~10.0	1.0	×	0x0850
F898	Power consumption correction coefficient	50.0~100.0	80.0	√	0x0862
F899	Power consumption clear	0: invalid 1: Valid	0	√	0x0863

Communication parameter: F900-F930

F900	Communication Address	1~255: single inverter address 0: broadcast address	1	√	0x0900
F901	Communication Mode	1: ASCII 2: RTU	2	√	0x0901
F902	Stop bits	1~2	2	√	0x0902
F903	Parity Check	0: Invalid 1: Odd 2: Even	0	√	0x0903
F904	Baud Rate	0: 1200; 1: 2400; 2: 4800; 3: 9600 ; 4: 19200 5: 38400 6: 57600 7: 115200	3	√	0x0904
F905	Communication timeout period (S)	0.0~3000.0	0.0	√	0x0905
F907	Time 2 of communication timeout (S)	0.0~3000.0	0.0	√	0x0907
F926	CAN baud rate (kbps)	0:20 1:50 2:100 3:125 4: 250 5:500 6:1000	6	√	0x091A
F928	BACnet address	0~127	1	√	0x091C
F929	BACnet baud rate (bps)	9.6\19.2\38.4\57.6\76.8\115.0	9.6	√	0x091D
F930	Keypad disconnected protection(s)	0: Invalid 1~10	0	√	0x091E
F933	BACnet low byte of device No.	0~65535	1	√	0x0921
F950	Address 1 Read by Modbus Communication	0~0xFFFF	0x1000	√	0x0932
F951	Address 2 Read by Modbus Communication	0~0xFFFF	0x1001	√	0x0933
F952	Address 3 Read by Modbus Communication	0~0xFFFF	0x1002	√	0x0934
F953	Address 4 Read by Modbus Communication	0~0xFFFF	0x1003	√	0x0935
F954	Address 5 Read by Modbus Communication	0~0xFFFF	0x1004	√	0x0936
F955	Address 6 Read by Modbus Communication	0~0xFFFF	0x1005	√	0x0937
F956	Address 7 Read by Modbus Communication	0~0xFFFF	0x1006	√	0x0938
F957	Address 8 Read by Modbus communication	0~0xFFFF	0x1007	√	0x0939
F958	Address 9 Read by Modbus Communication	0~0xFFFF	0x1008	√	0x093A
F959	Address 10 Read by Modbus Communication	0~0xFFFF	0x1009	√	0x093B
F960	CAN Master-slave proportional control	0:Invalid 1: Valid	0	×	0x093C
F962	BACnet high byte of device No.	0~63	0	√	0x093E

PID parameters: FA00-FA80

FA00	Water supply mode	0: Single pump (PID control mode) 1: Fixed mode 2: Timing interchanging 5: Dormancy interchanging 6: fixed pumps interchanging by time 7: fixed pumps interchanging at sleep 10: master/slave fixed mode 11: master/slave interchanging by time 12: master/slave interchanging at sleep	0	×	0x0A00
FA01	PID adjusting target given source	0: FA04 1: AI1 2: AI2 4: FI (pulse frequency input)	0	×	0x0A01
FA02	PID adjusting feedback given source	1: AI1 2: AI2 3: FI (pulse frequency input) 4: Modbus given 5: Running current 6: Output power 7: Output torque 8: AI1-AI2 9: AI1+AI2 10: Max (AI1, AI2) 11. Min (AI1, AI2)	1	×	0x0A02
FA03	Max limit of PID adjusting (%)	FA04~FA50	100.0	√	0x0A03
FA04	Digital setting value of PID adjusting (%)	FA05~FA03	50.0	√	0x0A04
FA05	Min limit of PID adjusting (%)	0.0~FA04	0.0	√	0x0A05
FA06	PID polarity	0: Positive feedback 1: Negative feedback	1	×	0x0A06
FA07	Dormancy function selection	0: Valid 1: Invalid	1	×	0x0A07
FA09	Min frequency of PID adjusting (Hz)	Max(F112, 0.1)~F111	5.00	√	0x0A09
FA10	Dormancy delay time (S)	0~500.0	15.0	√	0x0A0A
FA11	Wake delay time (S)	0.0~3000	3.0	√	0x0A0B
FA12	PID max frequency(Hz)	FA09~F111	50.00	√	0x0A0C
FA13	pressure setpoint source of filling inlet	0: invalid 1: AI1 2: AI2	0	√	0x0A0D
FA18	Whether PID adjusting target is changed	0: Invalid 1: Valid	1	×	0x0A12
FA19	Proportion Gain P	0.00~10.00	0.30	√	0x0A13
FA20	Integration time I (S)	0.0~100.0	0.3	√	0x0A14
FA21	Differential time D (S)	0.1~10.0	0.1	√	0x0A15
FA22	PID sampling period (mS)	1~500	5	√	0x0A16

FA23	PID negative frequency output selection	0: Invalid 1: Valid 2: Only negative output	0	√	0x0A17
FA24	Switching Timing unit setting	0: hour 1: minute	0	×	0x0A18
FA25	Switching Timing Setting	1~9999	100	×	0x0A19
FA26	Under-load protection mode	0: No protection 1: Protection by contactor 2: Protection by PID 3: Protection by current	0	×	0x0A1A
FA27	Current threshold of under-load protection (%)	10~150	80	√	0x0A1B
FA28	Waking time after protection (min)	1~3000	60	√	0x0A1C
FA29	PID dead time (%)	0.0~10.0	2.0	√	0x0A1D
FA30	Running Interval of restarting converter pump (S)	2.0~999.9	20.0	√	0x0A1E
FA31	Delay time of starting general pumps (S)	0.1~999.9	30.0	√	0x0A1F
FA32	Delay time of stopping general pumps (S)	0.1~999.9	30.0	√	0x0A20
FA33	stop mode when constant pressure water supply	0: free stop 1: deceleration to stop	0	×	0x0A21
FA34	Pressure measurement unit	0: % 1: Mpa 2: bar 3: psi 4: CM 5: M 6: CM/Seg 7: M/Seg 8: °C 9: pa 10: mb	0	√	0x0A22
FA36	Whether No.1 relay is started	0: Stopped 1: Started	0	×	0x0A24
FA37	Whether No.2 relay is started	0: Stopped 1: Started	0	×	0x0A25
FA38	Proportion gain Kp2	0.00~10.00	0.30	√	0x0A26
FA39	Integration time Ki2(S)	0.1~100.0	0.3	√	0x0A27
FA40	Differential time Kd2(S)	0.0~10.0	0.0	√	0x0A28
FA41	PI parameter switchover type	0: no switchover 1: reserved 2: Auto switchover 3: reserved	0	×	0x0A29
FA42	Switchover error 1	FA05~FA03	10.0	√	0x0A2A
FA43	Switchover error 2	FA42~FA03	50.0	√	0x0A2B
FA44	Master/slave control mode	0:same frequency 1: high efficiency mode	0	×	0x0A2C
FA45	Pressure setpoint compensation (%)	0.0~10.0	0	√	0x0A2D
FA47	The sequence of starting No 1 relay	1~20	20	×	0x0A2F
FA48	The sequence of starting No 2 relay	1~20	20	×	0x0A30

FA49	Filling inlet pressure range(%)	0.0~100.0	100.0	√	0x0A31
FA50	FA50 Empty outlet pressure range(%)	0.0~100.0	100.0	√	0x0A32
FA51	Pressure threshold of refilling at inlet (%)	FA52~FA49	0.01	√	0x0A33
FA52	Pressure threshold of water-lack at inlet(%)	0.0~FA51 0.0: invalid	0.00	√	0x0A34
FA53	Delay time for refilling at inlet(S)	0.0~60.0	0.0	√	0x0A35
FA54	Delay time for warning water-lack(S)	0.0~60.0	0.0	√	0x0A36
FA55	Master/slave pump number	0~14	0	×	0x0A37
FA56	Outlet sensor disconnection protection	0: invalid 1: valid	0	√	0x0A38
FA57	Inlet sensor disconnection protection	0: invalid 1: valid	0	√	0x0A39
FA58	Fire pressure given value (%)	0.0~100.0	80.0	√	0x0A3A
FA59	Emergency fire mode	0: Invalid 1: Emergency fire mode 1 2: Emergency fire mode 2	0	×	0x0A3B
FA60	Running frequency of emergency fire	F112~F111	50.00	√	0x0A3C
FA62	When fire emergency control terminal is invalid	0: no stop 1: manual stop valid	0	×	0x0A3E
FA65	Signal Selection for Protection by Contactor	0: With and lack water 1: With water 2: Lack water	0	√	0x0A41
FA66	Duration time of under-load protection (S)	0~60	20.0	√	0x0A42
FA67	Dormancy mode	0: dormancy mode 1 1: dormancy mode 2	0	×	0x0A43
FA68	Given pressure offset 1 (%)	0.0~100.0	30.0	√	0x0A44
FA69	Given pressure offset 2 (%)	0.0~100.0	30.0	√	0x0A45
FA78	Flow detection enable	0: invalid 1: valid	0	√	0x0A4E
FA79	Interval time for flow detection (min)	1~60000	60	√	0x0A4F
FA80	Pressure Compensation for flow detection(%)	0.1~10.0	2.0	√	0x0A50
FA81	No flow restart delay (S)	0.0~3000.0	10.0	√	0x0A51
FA82	No.3 relay is available	0: not available 1: available	0	×	0x0A52
FA83	The sequence of starting No.	1~20	20	×	0x0A53

	3 relay				
FA84	Sleep mode	0: sleeping mode 1 1: sleeping mode 2	0	√	0x0A54
FA85	Dead Zone mode	0: ±dead zone 1: + dead zone	0	√	0x0A55
FA86	Internal PID pressure setpoint 2(%)	FA05~FA03	50.0	√	0x0A56
FA87	Internal PID pressure setpoint 3(%)	FA05~FA03	50.0	√	0x0A57
FA88	Internal PID pressure setpoint 4 (%)	FA05~FA03	50.0	√	0x0A58
FA89	Pump start counter			△	0x0A59
FA90	Switchover of inlet/outlet PID control	0: invalid 1: valid	0	√	0x0A5A
FA91	Inlet max pressure(%)	FA93~FA49	25.0	√	0x0A5B
FA92	Pressure of switch to inlet PID control(%)	FA94~FA49	5.0	√	0x0A5C
FA93	Inlet pressure setpoint(%)	FA94~FA91	10.0	√	0x0A5D
FA94	Inlet min pressure(%)	0.0~FA93	0.0	√	0x0A5E
FA95	Inlet PID control polarity	0: Positive 1: Negative	0	√	0x0A5F
FA96	Level control	0: Invalid 1: valid	0	×	0x0A60
FA98	Inverter pump stop when a fixed pump is switched on	0: invalid 1: valid	1	√	0x0A62
FA99	Parameter synchronizing	0: invalid 1: valid	0	×	0x0A63
FB00	Pump auto-tuning	0: invalid 1: valid	0	×	0x0B00
FB01	Pump auto-tuning time step(S)	0.1~5.0	1.0	√	0x0B01
FB02	Pump auto-tuning current(A)	0.0~F803	0.0	√	0x0B02
FB06	Current Limit Coefficient	0~200	60	√	0x0B06
FB07	Voltage Limit Proportion Coefficient	0~100	30	√	0x0B07
FB08	Voltage Limit Integral Coefficient	0~100	30	√	0x0B08
FB10	Outlet pressure setpoint of manual control(%)	FB13~FB15	50.0	√	0x0B0A
FB11	Outlet sleep frequency of manual control(Hz)	F112~F111	5.00	√	0x0B0B
FB12	Outlet Sleep delay time of	0.0~500.0	15.0	√	0x0B0C

	manual control (S)				
FB13	Outlet wakeup pressure setpoint of manual control(%)	0.0~FB10	0.0	√	0x0B0D
FB14	Outlet wakeup delay time of manual control(S)	0.0~3000.0	3.0	√	0x0B0E
FB15	Outlet max pressure of manual control(%)	FB10~FA50	100.0	√	0x0B0F
FB16	Dry operation protection	0: invalid 1: valid	0	√	0x0B10
FB17	Dry operation pressure (%)	0.0~FB23	0.0	√	0x0B11
FB18	Dry operation delay time(S)	0.0~300.0	60.0	√	0x0B12
FB19	Dry operation current(A)	0.1~1000.0			0x0B13
FB20	Pipe filling installation	0: invalid 1: valid	0	×	0x0B14
FB21	Pipe filling frequency(Hz)	0.00~FA12	5.00	√	0x0B15
FB22	Prefilling time (S)	0.0~300.0	60.0	√	0x0B16
FB23	Leakage pressure detection(%)	FB17~80.0 0.0: invalid	0.0	√	0x0B17
FB24	Leakage detecting time 1(S)	0.0~300.0	5.0	√	0x0B18
FB25	Leakage detecting time 2(S)	0.0~300.0	5.0	√	0x0B19
FB26	Leakage detecting time 3(S)	0.0~300.0	5.0	√	0x0B1A
FB27	Leakage detecting cycle	1~10	3	√	0x0B1B
FB28	Filling timeout (min)	1~3000	10	√	0x0B1C
FB29	Activate Manual/Auto control	0: invalid 1: valid	0	√	0x0B1D
FB31	Run time for cleaning(S)	1~3000	30	√	0x0B1F
FB32	Stop time for cleaning(S)	1~3000	30	√	0x0B20
FB33	Solar filtered time for frequency limit (S)	0.0~100.0	3.0	√	0x0B21
FB34	Solar mode enable	0: invalid 1: valid	0	×	0x0B22
FB35	Frequency limiting source	0: invalid 1: AI1 2: AI2	0	√	0x0B23
FB36	Outlet feedback compensation direction	0: positive 1: negative	0	√	0x0B24
FB37	Outlet feedback compensation display(%)	0.0~FA50	0.0	√	0x0B25
FB38	Inlet feedback compensation direction	0: positive 1: negative	0	√	0x0B26
FB39	Inlet feedback compensation	0.0~FA49	0.0	√	0x0B27

	display(%)				
FB40	Anti-freeze/Ant-irust function	0: invalid 1: valid	0	√	0x0B28
FB41	Stop time for anti-freeze /anti-rust (S)	1.0~3000.0	60.0	√	0x0B29
FB42	Run time for anti-freeze /anti-rust (S)	1.0~3000.0	60.0	√	0x0B2A
FB43	Well pump mode	0: invalid 1: valid	0	×	0x0B2B
FB44	Anti-return valve installed	0: invalid 1: valid	0	×	0x0B2C
FB45	Delay time for restart pump without anti-return valve (minute)	0~99	3	√	0x0B2D
FB46	Accelerating time for valid water supply(S)	0.0~100.0	0.0	×	0x0B2E
FB47	Decelerating time for valid water supply(S)	0.0~100.0	0.0	√	0x0B2F
FB48	Anti-jam function	0: invalid 1: valid	0	×	0x0B30
FB49	Jam current (%)	100~150	115	√	0x0B31
FB50	Jam judgement time (S)	0.1~60.0	10.0	√	0x0B32
FB51	Delay time for anti-jam running(S)	0.0~30.0	3.0	√	0x0B33
FB52	Anti-jam running time(S)	1.0~30.0	3.0	√	0x0B34
FB53	Number of times of anti-jam attempt	1~10	3	√	0x0B35
FB54	Max sunlight(W/m2)	FB55~1500	1500	×	0x0B36
FB55	Working sunlight(W/m2)	FB56~FB54	1000	×	0x0B37
FB56	FB56 Min sunlight(W/m2)	FB57~FB55	600	×	0x0B38
FB57	Alarm min sunlight (W/m2)	0~FB56 0: invalid	0	×	0x0B39
FB58	Open-circuit voltage of solar panel (V)	FB59~800	T3:682 T2/S2:379	×	0x0B3A
FB59	Max-power voltage of solar panel(V)	100~FB58	T3:556 T2/S2:309	×	0x0B3B
FB61	Voltage regulation coefficient	0.01~10.00	1.00	√	0x0B3C
FB80	Voltage regulation cycle	0.001~1.000	0.001	√	0x0B3D
FB80	Password for pump menu	0~9999	0	√	0x0B50

Torque control parameters: FC00-FC40

FC00	Speed/torque control selection	0: Speed control 1: Torque control 2: Terminal switchover	0	√	0x0C00
FC02	Torque accel/decel time (S)	0.1~100.0	1.0	√	0x0C02
FC06	Torque given channel	0: Digital given (FC09) 1: Analog input AI1 2: Analog input AI2 4: Pulse input channel FI 5: Modbus given	0	×	0x0C06
FC07	Torque given coefficient	0~3.000	3.000	×	0x0C07
FC09	Torque given command value (%)	0~300.0	100.0	√	0x0C09
FC14	Offset torque given channel	0: Digital given (FC17) 1: Analog input AI1 2: Analog input AI2 4: Pulse input channel FI 5: Reserved	0	×	0x0C0E
FC15	Offset torque coefficient	0~0.500	0.500	×	0x0C0F
FC16	Offset torque cut-off frequency (%)	FC18~100.0	10.00	×	0x0C10
FC17	Offset torque command value (%)	0~50.0	10.00	√	0x0C11
FC18	Bias torque cut-off frequency 0(%)	0.1~FC16	0.0	×	0x0C12
FC22	Forward speed limited channel	0: Digital given (FC23) 1: Analog input AI1 2: Analog input AI2 4: Pulse input channel FI 5: Reserved	0	×	0x0C16
FC23	Forward speed limited (%)	0~100.0	10.00	√	0x0C17
FC24	Reverse speed limited channel	0: Digital given (FC25) 1: Analog input AI1 2: Analog input AI2 4: Impulse input FI	0	×	0x0C18
FC25	Reverse speed limited (%)	0~100.0	10.0	√	0x0C19
FC28	Electric torque limited channel	0: Digital given (FC30) 1: Analog input AI1 2: Analog input AI2 4: Pulse input channel FI 5: Reserved	0	×	0x0C1C
FC29	Electric torque limited coefficient	0~3.000	3.000	×	0x0C1D
FC30	Electric torque limited (%)	0~300.0	200.0	√	0x0C1E

FC33	Braking torque limited channel	0: Digital given (FC35) 1: Analog input AI1 2: Analog input AI2 4: Pulse input channel FI 5: Reserved	0	×	0x0C21
FC34	Braking torque limited coefficient	0~3.000	3.000	×	0x0C22
FC35	Braking torque limited (%)	0~300.0	200.00	√	0x0C23
FC36	Lower Torque Limit Enabled	0: Invalid 1: Valid	0	×	0x0C24
FC37	Frequency for Lower Torque Limit	2.00~50.00	10.00	√	0x0C25
FC38	Filtering Time (ms)	0-5000	500	√	0x0C26
FC39	Max Torque (%)	0.0-300.0	250	×	0x0C27
FC40	Threshold of Lower Torque Limit	0-20.0	3.0	√	0x0C28
FC41	Threshold of Lower Frequency limit	1.00-10.00	1.00	√	0x0C29
FC48	Torque switchover enabled	0: Invalid 1: Valid	0	×	0x0C30
FC49	Current-limiting point 2 (%)	F608~200	190	√	0x0C31
FC50	Frequency switchover point 1(Hz)	1.00~FC51	10.00	√	0x0C32
FC51	Frequency switchover point 2(Hz)	FC50~F111	20.00	√	0x0C33

Time setting

FD00	Year	2000~9999	Local time	√	0x0D00
FD01	Month	1~12	5	√	0x0D01
FD02	Date	1~31	15	√	0x0D02
FD03	Week	1~7	1	√	0x0D03
FD04	Hour	0~23	8	√	0x0D04
FD05	Minute	0~59	0	√	0x0D05
FD06	Second	0~59	0	√	0x0D06
FD07	Supplying water on appointed date	0: invalid 1: valid	0	×	0x0D07
FD08	Supplying water on weekend	0: invalid 1: valid	0	×	0x0D08
FD09	Supplying water on workday	0: invalid 1: valid	0	×	0x0D09
FD10	Starting time 1 on appointed date	01.01~12.31	1.01	√	0x0D00
FD11	Stopping time 1 on appointed date	01.01~12.31	1.01	√	0x0D01
FD12	Pressure setpoint 1 on appointed date	FA05~FA03	0.0	√	0x0D02

FD13	Starting time 2 on appointed date	01.01~12.31	1.01	√	0x0D0D
FD14	Stopping time 2 on appointed date	01.01~12.31	1.01	√	0x0D0E
FD15	Pressure setpoint 2 on appointed date	FA05~FA03	0.0	√	0x0D0F
FD16	Starting time 3 on appointed date	01.01~12.31	1.01	√	0x0D10
FD17	Stopping time 3 on appointed date	01.01~12.31	1.01	√	0x0D11
FD18	Pressure setpoint 3 on appointed date	FA05~FA03	0.0	√	0x0D12
FD19	Starting time 4 on appointed date	01.01~12.31	1.01	√	0x0D13
FD20	Stopping time 4 on appointed date	01.01~12.31	1.01	√	0x0D14
FD21	Pressure setpoint 4 on appointed date	FA05~FA03	0.0	√	0x0D15
FD22	Starting time 5 on appointed date	01.01~12.31	1.01	√	0x0D16
FD23	Stopping time 5 on appointed date	01.01~12.31	1.01	√	0x0D17
FD24	Pressure setpoint 5 on appointed date	FA05~FA03	0.0	√	0x0D18
FD25	Starting time 6 on appointed date	01.01~12.31	1.01	√	0x0D19
FD26	Stopping time 6 on appointed date	01.01~12.31	1.01	√	0x0D1A
FD27	Pressure setpoint 6 on appointed date	FA05~FA03	0.0	√	0x0D1B
FD28	Starting time 7 on appointed date	01.01~12.31	1.01	√	0x0D1C
FD29	Stopping time 7 on appointed date	01.01~12.31	1.01	√	0x0D1D
FD30	Pressure setpoint 7 on appointed date	FA05~FA03	0.0	√	0x0D1E
FD31	Starting time 8 on appointed date	01.01~12.31	1.01	√	0x0D1F
FD32	Stopping time 7 on appointed date	01.01~12.31	1.01	√	0x0D20
FD33	Pressure setpoint 8 on appointed date	FA05~FA03	0.0	√	0x0D21
FD34	Starting time 1 at weekend	0.00~23.59	0.00	√	0x0D22
FD35	Stopping time 1 at weekend	0.00~23.59	0.00	√	0x0D23
FD36	Pressure setpoint 1 at weekend	FA05~FA03	0.0	√	0x0D24
FD37	Starting time 2 at weekend	0.00~23.59	0.00	√	0x0D25
FD38	Stopping time 2 at weekend	0.00~23.59	0.00	√	0x0D26
FD39	Pressure setpoint 2 at weekend	FA05~FA03	0.0	√	0x0D27
FD40	Starting time 3 at weekend	0.00~23.59	0.00	√	0x0D28
FD41	Stopping time 3 at weekend	0.00~23.59	0.00	√	0x0D29
FD42	Pressure setpoint 3 at weekend	FA05~FA03	0.0	√	0x0D2A

FD43	Starting time 4 at weekend	0.00~23.59	0.00	√	0x0D2B
FD44	Stopping time 4 at weekend	0.00~23.59	0.00	√	0x0D2C
FD45	Pressure setpoint 4 at weekend	FA05~FA03	0.0	√	0x0D2D
FD46	Starting time 5 at weekend	0.00~23.59	0.00	√	0x0D2E
FD47	Stopping time 5 at weekend	0.00~23.59	0.00	√	0x0D2F
FD48	Pressure setpoint 5 at weekend	FA05~FA03	0.0	√	0x0D30
FD49	Starting time 6 at weekend	0.00~23.59	0.00	√	0x0D31
FD50	Stopping time 6 at weekend	0.00~23.59	0.00	√	0x0D32
FD51	Pressure setpoint 6 at weekend	FA05~FA03	0.0	√	0x0D33
FD52	Starting time 7 at weekend	0.00~23.59	0.00	√	0x0D34
FD53	Stopping time 7 at weekend	0.00~23.59	0.00	√	0x0D35
FD54	Pressure setpoint 7 at weekend	FA05~FA03	0.0	√	0x0D36
FD55	Starting time 8 at weekend	0.00~23.59	0.00	√	0x0D37
FD56	Stopping time 8 at weekend	0.00~23.59	0.00	√	0x0D38
FD57	Pressure setpoint 8 at weekend	FA05~FA03	0.0	√	0x0D39
FD58	Starting time 1 on everyday	0.00~23.59	0.00	√	0x0D3A
FD59	Stopping time 1 on everyday	0.00~23.59	0.00	√	0x0D3B
FD60	Pressure setpoint 1 on everyday	FA05~FA03	0.0	√	0x0D3C
FD61	Starting time 2 on everyday	0.00~23.59	0.00	√	0x0D3D
FD62	Stopping time 2 on everyday	0.00~23.59	0.00	√	0x0D3E
FD63	Pressure setpoint 2 on everyday	FA05~FA03	0.0	√	0x0D3F
FD64	Starting time 3 on everyday	0.00~23.59	0.00	√	0x0D40
FD65	Stopping time 3 on everyday	0.00~23.59	0.00	√	0x0D41
FD66	Pressure setpoint 3 on everyday	FA05~FA03	0.0	√	0x0D42
FD67	Starting time 4 on everyday	0.00~23.59	0.00	√	0x0D43
FD68	Stopping time 4 on everyday	0.00~23.59	0.00	√	0x0D44
FD69	Pressure setpoint 4 on everyday	FA05~FA03	0.0	√	0x0D45
FD70	Starting time 5 on everyday	0.00~23.59	0.00	√	0x0D46
FD71	Stopping time 5 on everyday	0.00~23.59	0.00	√	0x0D47

FD72	Pressure setpoint 5 on everyday	FA05~FA03	0.0	√	0x0D48
FD73	Starting time 6 on everyday	0.00~23.59	0.00	√	0x0D49
FD74	Stopping time 6 on everyday	0.00~23.59	0.00	√	0x0D4A
FD75	Pressure setpoint 6 on everyday	FA05~FA03	0.0	√	0x0D4B
FD76	Starting time 7 on everyday	0.00~23.59	0.00	√	0x0D4C
FD77	Stopping time 7 on everyday	0.00~23.59	0.00	√	0x0D4D
FD78	Pressure setpoint 7 on everyday	FA05~FA03	0.0	√	0x0D4E
FD79	Starting time 8 on everyday	0.00~23.59	0.00	√	0x0D4F
FD80	Stopping time 8 on everyday	0.00~23.59	0.00	√	0x0D50
FD81	Pressure setpoint 8 on everyday	FA05~FA03	0.0	√	0x0D51

The second motor parameters: FE00-FE84

FE00	Motor Switchover	Ones: Motor selection 0: No. 1 motor 1: No. 2 motor 2: Terminal switchover Tens: control mode of No.2 motor 0: Sensorless vector control (SVC) 1: Closed-loop vector control (VC) 2: V/F control 3: Vector control 1	20	×	0x0E00
FE01	Rated Power of Motor 2(kW)	0.1~1000.0	Subject to model	×	0x0E01
FE02	Rated Voltage of Motor 2(V)	1~1300		×	0x0E02
FE03	Rated Current of Motor 2(A)	0.2~6553.5		×	0x0E03
FE04	Number of Motor 2 Poles	2~100	4	×	0x0E04
FE05	Rated speed of Motor 2(rpm)	1~30000	Subject to model	×	0x0E05
FE06	Motor 2 Stator Resistor	0.001~65.53Ω (≤15kW) 0.1~6553mΩ(>15kW)	Subject to model	×	0x0E06
FE07	Motor 2 Rotor Resistor	0.001~65.53Ω (≤15kW) 0.1~6553mΩ(>15kW)	Subject to model	×	0x0E07
FE08	Motor 2 Leakage Inductance	0.01~655.3mH (≤15kW) 0.001~65.53mH (>15kW)	Subject to model	×	0x0E08
FE09	Motor 2 Mutual Inductance	0.01~655.3mH (≤15kW) 0.001~65.53mH (>15kW)	Subject to model	×	0x0E09
FE10	Motor 2 Rated Frequency (Hz)	1.00~590.00	50.00	×	0x0E0

					A
FE11	Motor 2 No-load Current(A)	0.1~FE03	Subject to model	×○	0x0E0B
FE12	Type of Motor 2	0: Normal motor 1: Variable frequency motor	1	×	0x0E0C
FE13	Motor 2 Rotary Speed Loop KP1	1~100	30	√○	0x0E0D
FE14	Motor 2 Rotary Speed Loop KI1	0.01~10.00	0.50	√○	0x0E0E
FE15	Motor 2 Rotary Speed Loop KP2	1~100	20	√○	0x0E0F
FE16	Motor 2 Rotary Speed Loop KI2	0.01~10.00	1.00	√○	0x0E10
FE17	Motor 2 Switching Frequency 1	0.00~F818	5.00	√	0x0E11
FE18	Motor 2 Switching Frequency 2	FE17~F111	10.00	√	0x0E12
FE19	Accel/decel Time of Motor 2	0: Same with accel/decel time of motor 1 1: 1 st accel/decel time 2: 2 ^{ed} accel/decel time	0	√	0x0E13
FE20	Torque Compensation of Motor 2	1~20	Subject to model	×	0x0E14
FE21	Overload Coefficient of Motor 2	20~100	100	×	0x0E15
FE22	Motor 2 Overloading Pre-alarm Coefficient (%)	50~100	80	×	0x0E16
FE23	Motor 2 Oscillation Inhibition coefficient	0~100	Subject to model	×	0x0E17
FE25	Motor 2 Speed loop Filtering Constant	0~100	0	√	0x0E19
FE27	Max Torque when Speed Control	0.0~250.0	200.0	√	0x0E1B
FE33	Motor 2 Record of the Latest Malfunction Type			△	0x0E21
FE34	Motor 2 Record of Malfunction Type for Last but One			△	0x0E22
FE35	Motor 2 Record of Malfunction Type for Last but Two			△	0x0E23
FE36	Motor 2 Fault Frequency of the Latest Malfunction (Hz)			△	0x0E24
FE37	Motor 2 Fault Current of the			△	0x0E25

	Latest Malfunction(A)				
FE38	Motor 2 Fault PN Voltage of the Latest Malfunction(V)			△	0x0E26
FE39	Motor 2 Fault Frequency of Last Malfunction but One (Hz)			△	0x0E27
FE40	Motor 2 Fault Current of Last Malfunction but One(A)			△	0x0E28
FE41	Motor 2 Fault PN Voltage of Last Malfunction but One(V)			△	0x0E29
FE42	Motor 2 Fault Frequency of Last Malfunction but Two (Hz)			△	0x0E2A
FE43	Motor 2 Fault Current of Last Malfunction but Two(A)			△	0x0E2B
FE44	Motor 2 Fault PN Voltage of Last Malfunction but Two(V)			△	0x0E2C
FE45	Motor 2 Record of Overcurrent Protection Fault Times			△	0x0E2D
FE46	Motor 2 Record of Overvoltage Protection Fault Times			△	0x0E2E
FE47	Motor 2 Record of Overheat Protection Fault Times			△	0x0E2F
FE48	Motor 2 Record of Overload Protection Fault Times			△	0x0E30
FE49	Motor 2 Software Overcurrent Coefficient	0.50~3.00	2.50	×	0x0E31
FE50	Motor 2 Software Overcurrent Times			△	0x0E32
FE51	Motor 2 Encoder Line Numbers	1~9999	1000	×○	0x0E33
FE76	Injection Current when No Load	0.0~100.0	20.0	×○	0x0E4C
FE77	Injection Current Compensation when No Load	0.0~50.0	0.0	×○	0x0E4D
FE78	Compensation Cut-off Point	0.0~50.0	10.0	×○	0x0E4E
FE79	Injection Current when Heavy Load	0.0~100.0	0.0	×○	0x0E4F

Parameters display:

H000	Running frequency / target frequency (Hz)			△	0x4300
H001	Speed with load / target speed			△	0x4301
H002	Output current (A)			△	0x4302
H003	Output voltage (V)			△	0x4303
H004	PN voltage (V)			△	0x4304
H005	PID feedback value (%)			△	0x4305
H006	Temperature (°C)			△	0x4306
H007	Count values			△	0x4307
H008	Linear speed			△	0x4308
H009	PID given value (%)			△	0x4309
H012	Output power			△	0x430C
H013	Output torque (%)			△	0x430D
H014	Target torque (%)			△	0x430E
H016	Limit-voltage Reference Value			△	0x430F
H017	Current stage speed for multi-stage speed			△	0x4310
H018	Input pulse frequency (0.01KHz)			△	0x4311
H019	Feedback speed (Hz)			△	0x4313
H020	Feedback speed (rpm)			△	0x4314
H021	Monitoring AI1			△	0x4315
H022	Monitoring AI2			△	0x4316
H025	Power-On time (h)			△	0x4319
H026	Running time (h)			△	0x431A
H027	Input pulse frequency (Hz)			△	0x431B
H028	Communication setting value			△	0x431C
H029	Accumulated running time (S)			△	0x431D
H030	Main frequency X (Hz)			△	0x431E
H031	Accessorial frequency Y(Hz)			△	0x431F
H032	Communication status of master/slave			△	0x4320

H035	Slave number			△	0x4323
H036	Accumulated power-on time(h)			△	0x4324
H037	Accumulated running time(h)			△	0x4325
H038	Low-level power consumption(kW.H)			△	0x4326
H039	High-level power consumption(MW.H)			△	0x4327
H040	Inlet pressure(%)			△	0x4328

Note: × indicating that function code can only be modified in stop state.

√ indicating that function code can be modified both in stop and run state.

△ indicating that function code can only be checked in stop or run state but cannot be modified.

○ indicating that function code cannot be initialized as inverter restores manufacturer's value but can only be modified manually.

* indicating that function code can only be modified by manufacture.

Appendix 7 Master/slave control

I. Overview

When several water pumps work together in the same system, two types of working patterns can be provided, one of which is traditional PID control of several water pumps based on their collected feedback pressure, the other one is the cooperative control of master drive and slave drive, which is also called master/slave control. The implement methods and characteristics are:

1. Master and slave drives are connected by CAN communication, the highest communication baud rate can reach 1M. Max 14 water pumps work in network.
2. Master collects pipe network pressure and proceeds on PID adjusting; automatically put into slave operation in turn when under pressure; when pressure is higher than limit, cut off the slave automatically to reach the intelligent optimum control and realize stable pipe pressure.
3. When the master water pump in the network is cut off because of failure, the new master will be selected from the rest slaves to take the control without human manual intervention.

II. signal connection

1. CAN communication is adopted.
2. CAN communication distance

The distance is measured value in the experiment, it has some difference with actual communication distance. CAN baud rate is closely related to communication distance, lower the baud rate properly is the distance is too long. User should adjust the distance according to actual situation, and shielding cable is recommended.

3. Control cables are connected to master, master is connected to slave by communication cable.

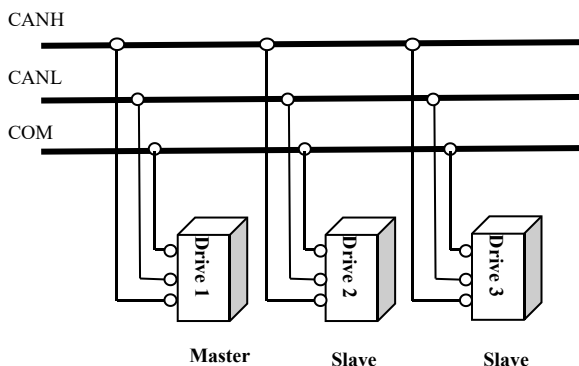

III. System debugging

1. Please make sure all cables are connected correctly. Set motor parameters, test control loop and motor running when inverter runs at low frequency in V/F control mode.
2. Check motor running direction. Each motor should run separately in V/F control mode, all motor running directions should be the same, if the running direction is different, please change any two phases of motor.
3. Motor parameter study: Before setting master/slave control mode, set motor parameter correctly to study each motor parameters separately.
4. Action logic: Master collects pipe network pressure and proceeds on PID adjusting, if master accelerates to max frequency delay time FA31 but lack of the pressure, master continues running and start one slave to run at same time; if still lack of the pressure, run another slave. When master and slave run together, if the pressure is too large, master decelerates to min frequency; if the pressure is still too large after delay time FA32, cut off slave; if cutting off all slaves, only one master runs in min frequency and the pressure still too large after delay time FA10, the master stops freely and enters dormancy status, "nP" is displayed on inverter.
5. Master/slave logic: If master offline or fails over 1s, system will select master from the rest slaves automatically.
6. All inverters in use need to set different local address by F900.

IV. Parameters setting

Function code	Definition	Setting range	Setting value	Remarks
F203	Main frequency source X	0: Digital setting memory; 1: External analog AI1; 2: External analog AI2; 3: Pulse input given; 4: Stage speed control; 5: Digital given no memory;	9	Must be

		6~8: Reserved 9: PID adjusting 10: Modbus		
F900	Communication Address	0~255	1	Must be
FA00	Water supply mode	0: Single pump (PID control mode) 1: Fixed mode 2: Timing interchanging 5: Dormancy interchanging 6: fixed pumps interchanging by time 7: fixed pumps interchanging at sleep 10: master/slave fixed mode 11: master/slave interchanging by time 12: master/slave interchanging at sleep	10	Must be
FA02	PID adjusting feedback given source	1: AI1 2: AI2 3: FI (pulse frequency input) 4: Modbus given 5: Running current 6: Output power 7: Output torque 8: AI1-AI2 9: AI1+AI2 10: Max(AI1, AI2) 11: Min(AI1, AI2)	2	Based on actual situation
FA04	Digital setting value of PID adjusting (%)	FA05~FA03	50.0	Based on actual situation
FA44	Master/slave control mode	0: same frequency 1: high efficiency mode	0	Based on actual situation

Note: user must set the parameters based on above table when the remarks are “must be”.

Appendix 8 Instructions for time period control

1. Parameters of clock

Parameter	Definition	Setting range	Setting value	Remarks
FD00	Year	2000~9999	Base on actual situation	Base on actual situation
FD01	Month	1~12	Base on actual situation	Base on actual situation
FD02	Date	1~31	Base on actual situation	Base on actual situation
FD03	Week	1~7	Base on actual situation	Base on actual situation
FD04	Hour	0~23	Base on actual situation	Base on actual situation
FD05	Minute	0~59	Base on actual situation	Base on actual situation
FD06	Second	0~59	Base on actual situation	Base on actual situation

2. Time period control

Parameter	Definition	Setting range	Setting value	Remarks
FD07	Supplying water on appointed date	0: invalid 1: valid	0	Base on actual situation
FD08	Supplying water on weekend	0: invalid 1: valid	0	Base on actual situation
FD09	Supplying water on workday	0: invalid 1: valid	0	Base on actual situation

- 1) Supplying water on appointed date: You can set the start time (month day), end time (month day), and target pressure within that time period.
- 2) Supplying water on workday: You can set the water supply pressure for each day (Monday to Sunday) according to the starting time (hours, minutes) and ending time (hours, minutes).
- 3) Supplying water on weekend: You can set the water supply pressure on weekends (Saturday, Sunday) according to the start time (hours, minutes) and end time (hours, minutes).
- 4) If the clock card is damaged, continue to operate according to the pressure set by FA04.

Parameter	Definition	Setting range	Setting value	Remarks
FD10	Starting time 1 on appointed date	01.01~12.31	1.01	Base on actual situation
FD11	Stopping time 1 on appointed date	01.01~12.31	1.01	Base on actual situation
FD12	Pressure setpoint 1 on appointed date	FA05~FA03	0.0	Base on actual situation
FD13	Starting time 2 on appointed date	01.01~12.31	1.01	Base on actual situation

FD14	Stopping time 2 on appointed date	01.01~12.31	1.01	Base on actual situation
FD15	Pressure setpoint 2 on appointed date	FA05~FA03	0.0	Base on actual situation
FD16	Starting time 3 on appointed date	01.01~12.31	1.01	Base on actual situation
FD17	Stopping time 3 on appointed date	01.01~12.31	1.01	Base on actual situation
FD18	Pressure setpoint 3 on appointed date	FA05~FA03	0.0	Base on actual situation
FD19	Starting time 4 on appointed date	01.01~12.31	1.01	Base on actual situation
FD20	Stopping time 4 on appointed date	01.01~12.31	1.01	Base on actual situation
FD21	Pressure setpoint 4 on appointed date	FA05~FA03	0.0	Base on actual situation
FD22	Starting time 5 on appointed date	01.01~12.31	1.01	Base on actual situation
FD23	Stopping time 5 on appointed date	01.01~12.31	1.01	Base on actual situation
FD24	Pressure setpoint 5 on appointed date	FA05~FA03	0.0	Base on actual situation
FD25	Starting time 6 on appointed date	01.01~12.31	1.01	Base on actual situation
FD26	Stopping time 6 on appointed date	01.01~12.31	1.01	Base on actual situation
FD27	Pressure setpoint 6 on appointed date	FA05~FA03	0.0	Base on actual situation
FD28	Starting time 7 on appointed date	01.01~12.31	1.01	Base on actual situation
FD29	Stopping time 7 on appointed date	01.01~12.31	1.01	Base on actual situation
FD30	Pressure setpoint 7 on appointed date	FA05~FA03	0.0	Base on actual situation
FD31	Starting time 8 on appointed date	01.01~12.31	1.01	Base on actual situation
FD32	Stopping time 7 on appointed date	01.01~12.31	1.01	Base on actual situation
FD33	Pressure setpoint 8 on appointed date	FA05~FA03	0.0	Base on actual situation
FD34	Starting time 1 at weekend	0.00~23.59	0.00	Base on actual situation
FD35	Stopping time 1 at weekend	0.00~23.59	0.00	Base on actual situation
FD36	Pressure setpoint 1 at weekend	FA05~FA03	0.0	Base on actual situation
FD37	Starting time 2 at weekend	0.00~23.59	0.00	Base on actual situation
FD38	Stopping time 2 at weekend	0.00~23.59	0.00	Base on actual situation
FD39	Pressure setpoint 2 at weekend	FA05~FA03	0.0	Base on actual situation
FD40	Starting time 3 at weekend	0.00~23.59	0.00	Base on actual situation
FD41	Stopping time 3 at weekend	0.00~23.59	0.00	Base on actual situation
FD42	Pressure setpoint 3 at weekend	FA05~FA03	0.0	Base on actual situation
FD43	Starting time 4 at weekend	0.00~23.59	0.00	Base on actual situation

FD44	Stopping time 4 at weekend	0.00~23.59	0.00	Base on actual situation
FD45	Pressure setpoint 4 at weekend	FA05~FA03	0.0	Base on actual situation
FD46	Starting time 5 at weekend	0.00~23.59	0.00	Base on actual situation
FD47	Stopping time 5 at weekend	0.00~23.59	0.00	Base on actual situation
FD48	Pressure setpoint 5 at weekend	FA05~FA03	0.0	Base on actual situation
FD49	Starting time 6 at weekend	0.00~23.59	0.00	Base on actual situation
FD50	Stopping time 6 at weekend	0.00~23.59	0.00	Base on actual situation
FD51	Pressure setpoint 6 at weekend	FA05~FA03	0.0	Base on actual situation
FD52	Starting time 7 at weekend	0.00~23.59	0.00	Base on actual situation
FD53	Stopping time 7 at weekend	0.00~23.59	0.00	Base on actual situation
FD54	Pressure setpoint 7 at weekend	FA05~FA03	0.0	Base on actual situation
FD55	Starting time 8 at weekend	0.00~23.59	0.00	Base on actual situation
FD56	Stopping time 8 at weekend	0.00~23.59	0.00	Base on actual situation
FD57	Pressure setpoint 8 at weekend	FA05~FA03	0.0	Base on actual situation
FD58	Starting time 1 on everyday	0.00~23.59	0.00	Base on actual situation
FD59	Stopping time 1 on everyday	0.00~23.59	0.00	Base on actual situation
FD60	Pressure setpoint 1 on everyday	FA05~FA03	0.0	Base on actual situation
FD61	Starting time 2 on everyday	0.00~23.59	0.00	Base on actual situation
FD62	Stopping time 2 on everyday	0.00~23.59	0.00	Base on actual situation
FD63	Pressure setpoint 2 on everyday	FA05~FA03	0.0	Base on actual situation
FD64	Starting time 3 on everyday	0.00~23.59	0.00	Base on actual situation
FD65	Stopping time 3 on everyday	0.00~23.59	0.00	Base on actual situation
FD66	Pressure setpoint 3 on everyday	FA05~FA03	0.0	Base on actual situation
FD67	Starting time 4 on everyday	0.00~23.59	0.00	Base on actual situation
FD68	Stopping time 4 on everyday	0.00~23.59	0.00	Base on actual situation
FD69	Pressure setpoint 4 on everyday	FA05~FA03	0.0	Base on actual situation
FD70	Starting time 5 on everyday	0.00~23.59	0.00	Base on actual situation
FD71	Stopping time 5 on everyday	0.00~23.59	0.00	Base on actual situation
FD72	Pressure setpoint 5 on everyday	FA05~FA03	0.0	Base on actual situation

FD73	Starting time 6 on everyday	0.00~23.59	0.00	Base on actual situation
FD74	Stopping time 6 on everyday	0.00~23.59	0.00	Base on actual situation
FD75	Pressure setpoint 6 on everyday	FA05~FA03	0.0	Base on actual situation
FD76	Starting time 7 on everyday	0.00~23.59	0.00	Base on actual situation
FD77	Stopping time 7 on everyday	0.00~23.59	0.00	Base on actual situation
FD78	Pressure setpoint 7 on everyday	FA05~FA03	0.0	Base on actual situation
FD79	Starting time 8 on everyday	0.00~23.59	0.00	Base on actual situation
FD80	Stopping time 8 on everyday	0.00~23.59	0.00	Base on actual situation
FD81	Pressure setpoint 8 on everyday	FA05~FA03	0.0	Base on actual situation

Note:

- 1) The end time of each segment needs to be greater than the start time,
- 2) The starting time of the next segment needs to be greater than or equal to the ending time of the previous segment.

3. Example of Time Control Application

1) Monthly and daily segmented water supply

For example, for water supply from January to March, the water supply pressure is 50%; Water supply from June to October, with a water supply pressure of 80%; No water supply during other time periods.

Parameter	Definition	Setting value
FD07	Supplying water on appointed date	1: valid
FD10	Starting time 1 on appointed date	01.01
FD11	Stopping time 1 on appointed date	03.31
FD12	Pressure setpoint 1 on appointed date	50.0%
FD13	Starting time 2 on appointed date	06.01
FD14	Stopping time 2 on appointed date	10.01
FD15	Pressure setpoint 2 on appointed date	80.0%

- 2) Monthly and daily segmented water supply, with water supplied every hour and minute of the day
For example, from May to October, the water supply pressure is 80.0% from 8:00 to 12:00 every day; During other time periods, the water supply pressure is 50.0%; No water supply in other months.

Parameter	Definition	Setting value
FD07	Supplying water on appointed date	1
FD09	PID given value (%)	1
FD10	Starting time 1 on appointed date	05.01
FD11	Stopping time 1 on appointed date	10.31
FD12	Pressure setpoint 1 on appointed date	0.0%
FD58	Starting time 1 on everyday	0.00
FD59	Stopping time 1 on everyday	07.59
FD60	Pressure setpoint 1 on everyday	50.0%
FD61	Starting time 2 on everyday	08.00
FD62	Stopping time 2 on everyday	11.59
FD63	Pressure setpoint 2 on everyday	80.0%
FD64	Starting time 3 on everyday	12.00
FD65	Stopping time 3 on everyday	23.59
FD66	Pressure setpoint 3 on everyday	50.0%

3) Monthly and daily segmented water supply, water supply is provided hourly and minute by minute every day, with special water supply on weekends

For example, from May to October, the water supply pressure is 80.0% from 8:00 to 12:00 every day; During other time periods, the water supply pressure is 50.0%; On weekends, 80% of the water is supplied throughout the day; No water supply in other months.

Parameter	Definition	Setting value
FD07	Supplying water on appointed date	1
FD08	Linear speed	1
FD09	PID given value (%)	1
FD10	Starting time 1 on appointed date	05.01
FD11	Stopping time 1 on appointed date	10.31
FD12	Pressure setpoint 1 on appointed date	0.0%
FD34	Starting time 1 at weekend	0.00
FD35	Stopping time 1 at weekend	23.59
FD36	Pressure setpoint 1 at weekend	80.0%

FD58	Starting time 1 on everyday	0.00
FD59	Stopping time 1 on everyday	07.59
FD60	Pressure setpoint 1 on everyday	50.0%
FD61	Starting time 2 on everyday	08.00
FD62	Stopping time 2 on everyday	11.59
FD63	Pressure setpoint 2 on everyday	80.0%
FD64	Starting time 3 on everyday	12.00
FD65	Stopping time 3 on everyday	23.59
FD66	Pressure setpoint 3 on everyday	50.0%

2024123002B